



DES-1008D/ DSS-8+ 8-Port 10/100Mbps Switch

Manual



RECYCLABLE
(Sep., 2006)
Rev.1.04

6DES1008D.07G

TABLE OF CONTENTS

ABOUT THIS GUIDE	1
PURPOSE.....	1
CONVENTIONS.....	1
INTRODUCTION.....	2
FAST ETHERNET TECHNOLOGY	2
SWITCHING TECHNOLOGY.....	2
FEATURES	4
UNPACKING AND SETUP	6
UNPACKING.....	6
SETUP	6
IDENTIFYING EXTERNAL COMPONENTS	7
FRONT PANEL	7
LED INDICATORS	7
REAR PANEL.....	8
CONNECTING THE DES-1008D/ DSS-8+	9
COMPUTER TO DES-1008D/ DSS-8+.....	9
HUB TO DES-1008D/ DSS-8+	9
DES-1008D/ DSS-8+ TO OTHER DEVICES	9
PORT SPEED & DUPLEX MODE	10
MOUNTING THE SWITCH ON A WALL	11
TECHNICAL SPECIFICATIONS	12
RJ-45 PIN SPECIFICATION.....	14

ABOUT THIS GUIDE

Congratulations on your purchase of the DES-1008D/ DSS-8+ Switch. This device integrates 100Mbps Fast Ethernet and 10Mbps Ethernet network capabilities into one high-performance, easy-to-use solution.

Purpose

This manual will familiarize you with the DES-1008D/ DSS-8+ Switch and guide you through the installation process.

Conventions

For simplicity, this documentation uses the term “Switch” (first letter upper case) to refer to the DES-1008D/ DSS-8+ Ethernet Switch, and “switch” (first letter lower case) to refer to other Ethernet switches.

INTRODUCTION

Fast Ethernet Technology

The growing importance of LANs and the increasing complexity of desktop computing applications are fueling the need for high performance networks. 100BASE-T (Fast Ethernet) provides a cost-effective and high-performance solution for small workgroups, SMBs (*Small to Medium Businesses*), and any network supporting bandwidth-intensive applications. Fast Ethernet technology operates at 10 times the speed of traditional Ethernet, offering maximum performance and enhanced capability for existing Ethernet-based networks.

100Mbps Fast Ethernet is a standard specified by the IEEE 802.3 LAN committee. It is an extension of the 10Mbps Ethernet standard with the ability to transmit and receive data at 100Mbps, while maintaining the CSMA/CD Ethernet protocol. Since the 100Mbps Fast Ethernet is compatible with all other 10Mbps Ethernet environments, it provides a straightforward upgrade path and takes advantage of the existing investment in hardware, software, and personnel training.

Switching Technology

Switching is a cost-effective way of increasing the total network capacity available to users on a LAN. If an Ethernet network begins to display symptoms of congestion, low throughput, slow response times, and high rates of collision, installing a switch to a network can preserve much or all of the existing network's cabling and workstation interface card infrastructure, while still greatly enhancing the throughput for users. A switch is a viable solution even if demanding applications, such as multimedia production and video conferencing, are on the horizon. The most promising techniques, as well as the best return on investment, could well consist of installing the right mixture of Ethernet switches.

A switch increases capacity and decreases network loading by dividing a local area network into different LAN segments. Dividing a LAN into multiple segments is one of the most common ways of increasing available bandwidth. If segmented correctly, most network traffic will remain within a single segment, enjoying the full-line speed bandwidth of that segment.

Switches provide full-line speed and dedicated bandwidth for all connections. This is in contrast to hubs, which use the traditional shared networking topology, where the connected nodes contend for the same network bandwidth. When two switching nodes are communicating, they are connected with a dedicated channel between them, so there is no contention for network bandwidth with other nodes. As a result, the switch reduces considerably, the likelihood of traffic congestion.

For Ethernet networks, a switch is an effective way of eliminating the problem of chaining hubs beyond the “two-repeater limit.” A switch can be used to split parts of the network into different collision domains, making it possible to expand your Ethernet network beyond the 205-meter network diameter limit for 10BASE-TX networks. Switches supporting both 10Mbps Ethernet and 100Mbps Fast Ethernet are also ideal for bridging between existing 10Mbps networks and newer 100Mbps networks.

Switching LAN technology is a marked improvement over the previous generation of network hubs and bridges, which were characterized by higher latencies. Routers have also been used to segment local area networks, but the cost of a router, the setup and maintenance required, make routers relatively impractical. Today switches are an ideal solution for most kinds of local area network congestion problems.

Features

The DES-1008D/ DSS-8+ is a high performance switch designed specifically for environments where traffic on the network and the number of users increase continuously.

The DES-1008D/ DSS-8+, with its small, compact size, was specifically designed for small to mid-sized workgroups. The DES-1008D/ DSS-8+ can be installed where space is limited; moreover, it provides immediate access to a rapidly growing network through a wide range of user-reliable functions.

The DES-1008D/ DSS-8+ is ideal for deployment with multiple high-speed servers for 10Mbps or 100Mbps shared-bandwidth workgroups. With the highest bandwidth at 200Mbps (100Mbps full-duplex mode), any port can provide workstations with a congestion-free data pipe for simultaneous access to the server.

The DES-1008D/ DSS-8+ is scalable, allowing two or more DES-1008D/ DSS-8+s to be cascaded together. Since all ports support 200Mbps, any one of its eight ports may be used to cascade to an additional switch to open a Full-Duplex Fast Ethernet pipe.

The DES-1008D/ DSS-8+ is the perfect choice for a department or office planning to upgrade to Fast Ethernet. The DES-1008D/ DSS-8+ can accommodate 10Mbps or 100Mbps devices, providing a flexible solution for existing (10Mbps) Ethernet workgroups.

The DES-1008D/ DSS-8+ combines dynamic memory allocation with store-and-forward switching to ensure that the buffer is effectively allocated for each port; and it controls the data flow between the transmit and receive nodes to guarantee against possible packet loss.

The DES-1008D/ DSS-8+ is an unmanaged 10/100Mbps Fast Ethernet switch that offers solutions for the accelerating bandwidth needs of small Ethernet workgroups.

Other key features include:

- Store-and-forward switching scheme capability. As the result of

complete frame checking and error frame filtering, this scheme prevents error packages from transmitting among segments.

- Auto-MDI/MDI-X. Detects the type of cable you are using, Crossover or Straight-Through, and automatically adjusts per port, allowing you to also use any port as an uplink port—the choice is yours. No more worries about whether you are using the right cable type or not. Auto MDI/MDI-X cable-type detection gives you true ‘plug and play’ capability.
- Nway Auto-negotiation for any port. This allows for auto-sensing of speed (10/100Mbps) and duplex mode (10/20/100/200Mbps), providing an automatic and flexible solution for the network.
- Flow control for any port. This minimizes dropped packets by sending out collision signals when the port’s receiving buffer is full. Note that flow control is only available in half duplex mode.
- Data filtering rate eliminates all error packets, runts, etc., per port at wire-speed for 100Mbps operation and 10Mbps operation.

UNPACKING AND SETUP

Unpacking

Open the box and carefully unpack it. The box should contain the following items:

1. One DES-1008D/ DSS-8+: 8-Port 10/100Mbps Ethernet Switch
2. One External Power Adapter
3. Four Rubber Feet
4. Nylon screw anchors and T3 x 15L screws
5. This Manual
6. Quick Installation Guide

If any item is missing or damaged, please contact your local reseller for a replacement.

Setup

The setup of the DES-1008D/ DSS-8+ can be performed using the following steps:

- The power outlet should be within 1.82 meters (6 feet) of the Switch.
- Visually inspect the DC power jack and make sure that it is fully secured to the power adapter.
- Do not cover the ventilation holes on the sides of the Switch, and make sure there is adequate ventilation around it.
- Do not place heavy objects on the switch.

IDENTIFYING EXTERNAL COMPONENTS

Front Panel

The figure below shows the front panel of the DES-1008D/ DSS-8+.

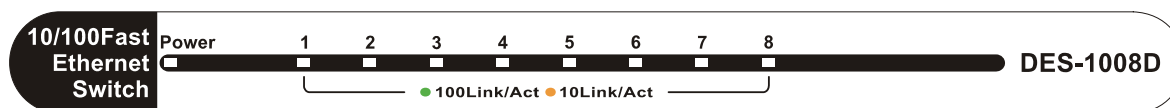

Front Panel LED Indicators

LED Indicators

■ Power Indicator

This green indicator light is on when the DES-1008D/ DSS-8+ is receiving power; otherwise, it is off.

■ 100Mbps Link/Activity, 10Mbps Link/Activity Indicator (100 Link/Act (green), 10 Link/Act (amber))

This LED indicator light is green when the port is connected to a 100Mbps Fast Ethernet station. The green indicator blinks as Fast Ethernet data is transmitted or received. The indicator light is amber when the port is connected to a 10Mbps Ethernet station, or other network device. The amber indicator blinks as Ethernet data is transmitted or received.

Rear Panel

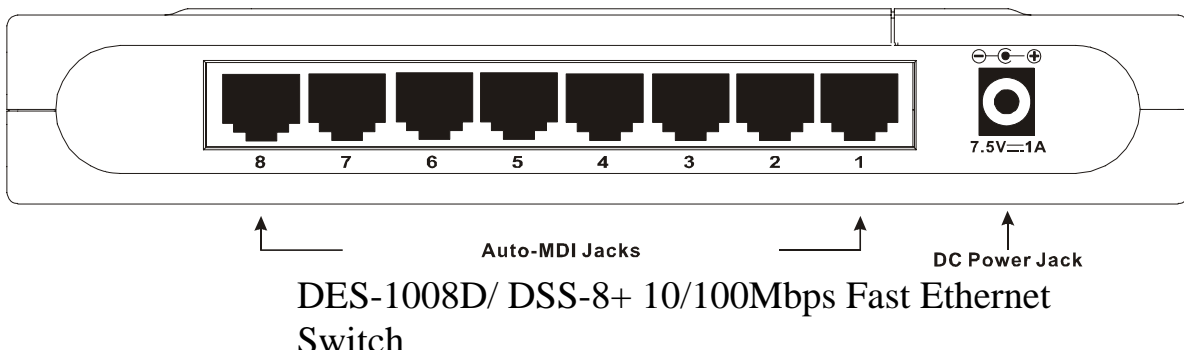

Auto MDI/MDI-X Ports:

All ports support automatic MDI/MDI-X cable-type detection, which eliminates the issue of choosing the right cable (Crossover or Straight-Through). The Auto MDI/MDI-X function makes it simple to connect to the Switch using either a Crossover or Straight-Through CAT5 cable into any port—the choice is yours.

DC Power Jack:

Power is supplied through an external DC power adapter. Check the technical specification section for information about the DC power input voltage.

Since the DES-1008D/ DSS-8+ does not include a power button, plugging its power adapter into a power outlet will immediately power it on.

CONNECTING THE DES-1008D/ DSS-8+

Computer to DES-1008D/ DSS-8+

A computer can be connected to the DES-1008D/ DSS-8+ via a two-pair Category 3, 4, 5 UTP/STP Straight-Through or Crossover cable. A computer equipped with a RJ-45 10/100Mbps port can be connected to any of the eight DES-1008D/ DSS-8+ ports.

The LED indicators for the computer connection depend on the capability of the computer's Ethernet card. If the LED indicators are not lit after making a proper connection, check the computer's Ethernet card, the cable, or the DES-1008D/ DSS-8+'s conditions and connections.

Hub to DES-1008D/ DSS-8+

A hub (10BASE-T or 100BASE-TX) can be connected to the DES-1008D/ DSS-8+ via a two-pair Category 3, 4, or 5 UTP/STP Straight-Through or Crossover cable. For 100Mbps operation a Category 5 cable **must** be used. The connection is accomplished from any port of the hub to any port of the DES-1008D/ DSS-8+.

DES-1008D/ DSS-8+ to other devices

The DES-1008D/ DSS-8+ can be connected to another switch or other devices (routers, bridges, etc.) via a two-pair Category 3, 4, 5 UTP/STP Straight-Through or Crossover cable. A Category 5 cable **must** be used for 100Mbps operation. The connection can be accomplished from any (MDI-X) port on the DES-1008D/ DSS-8+ to any of the 10Mbps or 100Mbps (MDI-X) ports on another switch or other devices.

Port Speed & Duplex Mode

After plugging the selected cable to a specific port, the system uses auto-negotiation to determine the transmission mode, auto-detecting the network speed (10Mbps or 100Mbps) for any new twisted-pair connection.

If the attached device **does not** support auto-negotiation or has auto-negotiation disabled, an auto-sensing process is initiated to select the speed and **half-duplex** mode is selected.

MOUNTING THE SWITCH ON A WALL

The DES-1008D/ DSS-8+ can also be mounted on a wall. Two mounting slots are provided on the bottom of the switch for this purpose. Please make sure that the front panel is exposed in order to view the LEDs. Please refer to the illustration below:

A.) Mounting on a cement wall

1. Mount the Nylon screw anchors into a cement wall.
2. Drive the T3 x 15L screws into the Nylon screw anchors.
3. Hook the mounting holes of the switch back on the screws; you have completed the wall-mount.

B.) Mounting on a wood wall

1. Drive the T3 x 15 L screws into the wood wall.
2. Hook the mounting holes of the switch back on the screws; you have completed the wall-mount.

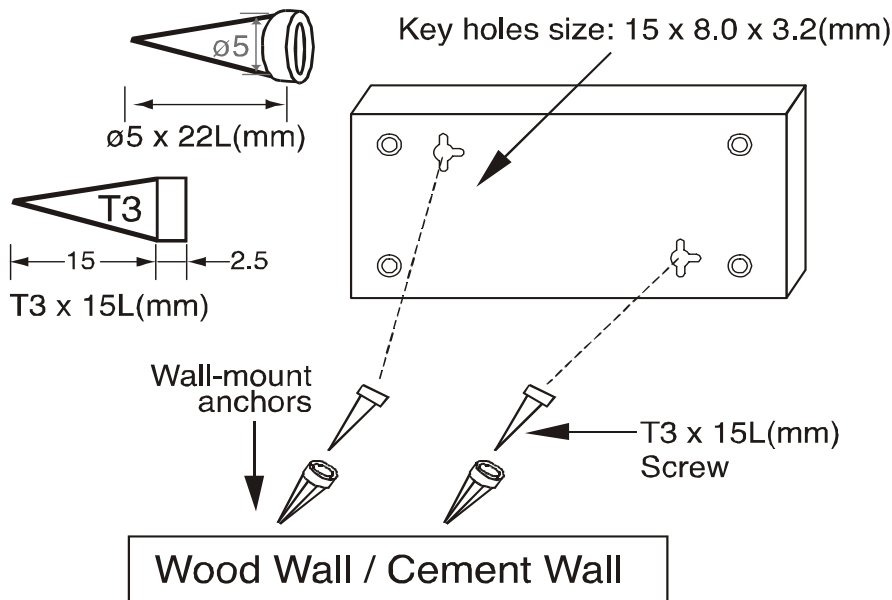

(1) 3/4 inch minimum
for wood wall

(2) 3 inch minimum
for cement wall.

TECHNICAL SPECIFICATIONS

General	
Standards	IEEE 802.3 10BASE-T Ethernet IEEE 802.3u 100BASE-TX Fast Ethernet IEEE 802.3x Flow Control
Protocol	CSMA/CD
Data Transfer Rate	Ethernet: 10Mbps (half duplex), 20Mbps (full-duplex) Fast Ethernet: 100Mbps (half duplex), 200Mbps (full- duplex)
Topology	Star
Network Cables	10BASE-T: 2-pair UTP Cat. 3,4,5 (100 m), EIA/TIA- 568 100-ohm STP (100 m) 100BASE-TX: 2-pair UTP Cat. 5 (100 m), EIA/TIA-568 100-ohm STP (100 m)
Number of Ports	8 x 10/100Mbps auto-negotiation, auto MDI-X ports
Physical and Environmental	
DC inputs	DC 7.5V / 1A DC 5V/1.2A AC 9V /1A [Different power lists would be packed for different shipping regions]
Power Consumption	3.37 Watts (Max)
Temperature	Operating: 0° ~ 50° C (32° to 122° F), Storage: -10° ~ 70° C (14°to 158° F)
Humidity	Operating: 10% ~ 90%, Storage: 5% ~ 90%
Dimensions	192.5 x 118.5 x 32 mm (W x H x D) (approx. 7.5 x 4.5 x 1.25 inches)
EMI:	FCC Class B, ICES-003 Class B, CE Mark B, VCCI Class B
Safety:	CSA International

Performance

Transmission Method:	Store-and-forward
RAM Buffer	64KBytes per device
Filtering Address Table	1K entries per device
Packet Filtering / Forwarding Rate:	10Mbps Ethernet: 14,880/pps 100Mbps Fast Ethernet: 148,800/pps
MAC Address Learning:	Automatic update

RJ-45 PIN SPECIFICATION

The following diagram and tables show the standard RJ-45 receptacle/connector and their pin assignments.

RJ-45 Connector pin assignment	
Contact	Media Direct Interface Signal
1	Tx + (transmit)
2	Tx - (transmit)
3	Rx + (receive)
4	Not used
5	Not used
6	Rx - (receive)
7	Not used
8	Not used

RJ-45 pin assignment

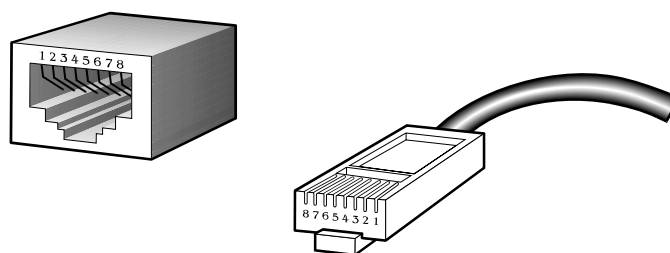

Standard RJ-45 receptacle/connector

