



DSL-502T
ADSL Router
User 's Guide

(December 2004)

651SL502T045

FCC Warning

This equipment has been tested and found to comply with the limits for a Class A digital device, pursuant to Part 15 of the FCC Rules. These limits are designed to provide reasonable protection against harmful interference when the equipment is operated in a commercial environment. This equipment generates, uses, and can radiate radio frequency energy and, if not installed and used in accordance with this user's guide, may cause harmful interference to radio communications. Operation of this equipment in a residential area is likely to cause harmful interference in which case the user will be required to correct the interference at his own expense.

CE Mark Warning

This is a Class A product. In a domestic environment, this product may cause radio interference in which case the user may be required to take adequate measures.

Table Of Contents

About This User's Guide.....	v
BEFORE YOU START	V
Installation Overview	v
The Setup Wizard	v
PACKING LIST.....	V
INSTALLATION REQUIREMENTS	VI
Installing the USB Driver	ix
INTRODUCTION	1
Router Description and Operation	1
Standards Compatibility and Compliance.....	3
Front Panel Display.....	4
Rear Panel.....	5
HARDWARE INSTALLATION	6
Power on Router.....	6
Factory Reset Button.....	6
Network Connections	6
BASIC ROUTER CONFIGURATION.....	8
Configuring IP Settings on Your Computer.....	8
Access the Configuration Manager.....	14
Login to Home Page.....	14
Configure the Router	15
Using the Setup Wizard	16
Configure WAN Connection.....	20
PPPoE and PPPoA Connection for WAN.....	21
Bridged Connection for WAN	22
Static IP Address for WAN.....	23
Multiple Private Virtual Connections.....	24
LAN IP Settings	26
DHCP Server Settings for the LAN	27
DNS Server Settings	28
Save Settings and Reboot.....	29
ADVANCED ROUTER MANAGEMENT	30
UPnP	31
Port Forwarding.....	32
DMZ	34
Filters.....	35
Firewall.....	37

NAT.....	38
ATM.....	39
Static Routing	40
Dynamic Routing (RIP).....	41
Remote Access.....	42
Tools and Utilities.....	43
Change System Password	43
Save or Load Configuration File	44
Restore Factory Default Settings.....	44
Time.....	45
Firmware Upgrade	46
Test.....	47
Save Settings and Reboot.....	48
Router Status Information.....	49
Device Information Display	49
DHCP Clients	50
Log.....	50
Traffic.....	51
ADSL.....	51
TECHNICAL SPECIFICATIONS	52
IP ADDRESS SETUP.....	54
IP CONCEPTS	56
MICROFILTERS AND SPLITTERS.....	59

About This User's Guide

This user's guide provides instructions on how to install the DSL-502T ADSL Router and use it to provide Internet access for a computer or an Ethernet LAN.

If you are using a computer with a functioning Ethernet port, the quickest and easiest way to set up the DSL-502T is to follow the instructions provided in the **Quick Installation Guide**. To install the USB driver, click the "Install DSL-502T" link on the initial pop-up menu that appears shortly after inserting the CD and follow the instructions as they are presented. If the menu fails to appear, explore the CD, double-click the **autorun.exe** file or find the file **Setup.exe** in the folder labeled **USBDRIVER** and double-click it to launch the installation software.

Before You Start

Please read and make sure you understand all the prerequisites for proper installation of your new Router. Have all the necessary information and equipment on hand before beginning the installation.

Installation Overview

The procedure to install the Router can be described in general terms in the following steps:

1. Gather information and equipment needed to install the device. Before you begin the actual installation make sure you have all the necessary information and equipment.
2. Install the hardware, connect the cables to the device and connect the power adapter. You will need to install a software driver to use the USB port. See the instructions below or QIG for more details..
3. Check the IP settings on your computer and change them if necessary so the computer can access the web-based software built into the Router.
4. Use the web-based management software to configure the device to suit the requirements of your ADSL service and requirements of your local network.

The Setup Wizard

Many users will be able to configure all the settings necessary to use the DSL-502T with the Setup Wizard. For ADSL connections that use PPPoE or PPPoA connections, the simplest way to setup the DSL-502T is to use the Setup Wizard to configure the Internet connection. Once you access the web interface used to configure the device, just launch the Setup Wizard to configure your Internet connection.

If you are connecting a computer to the Router via the USB interface, you must first install the USB driver. Follow the installation instructions below to install the USB driver.

Packing List

Open the shipping carton and carefully remove all items. Make sure that you have the items listed here.

1. One DSL-502T ADSL Ethernet Router
2. One CD-ROM containing the User's Guide, USB driver and Quick Installation Guide
3. One twisted-pair telephone cable used for ADSL connection
4. One straight-through Ethernet cable
5. One AC power adapter suitable for your electric service
6. One Inline Telephone Filter
7. One Quick Installation Guide

Installation Requirements

In order to establish a connection to the Internet it will be necessary to provide information to the Router that will be stored in its memory. For some users, only their account information (Username and Password) is required. For others, various parameters that control and define the Internet connection will be required. You can print out the two pages below and use the tables to list this information. This way you have a hard copy of all the information needed to setup the Router. If it is necessary to reconfigure the device, all the necessary information can be easily accessed. Be sure to keep this information safe and private.

Low Pass Filters

Since ADSL and telephone services share the same copper wiring to carry their respective signals, a filtering mechanism may be necessary to avoid mutual interference. A low pass filter device can be installed for each telephone that shares the line with the ADSL line. These filters are easy to install passive devices that connect to the ADSL device and/or telephone using standard telephone cable. Ask your service provider for more information about the use of low pass filters with your installation.

Operating Systems

The DSL-502T uses an HTML-based web interface for setup and management. The web configuration manager may be accessed using any operating system capable of running web browser software, including Windows 98 SE, Windows ME, Windows 2000, and Windows XP.

Web Browser

Any common web browser can be used to configure the Router using the web configuration management software. The program is designed to work best with more recently released browsers such as Opera, Microsoft Internet Explorer® version 5.0, Netscape Navigator® version 4.7, or later versions. The web browser must have JavaScript enabled. JavaScript is enabled by default on many browsers. Make sure JavaScript has not been disabled by other software (such as virus protection or web user security packages) that may be running on your computer.

Ethernet Port (NIC Adapter)

Any computer that uses the Router must be able to connect to it through the Ethernet port on the Router. This connection is an Ethernet connection and therefore requires that your computer be equipped with an Ethernet port as well. Most notebook computers are now sold with an Ethernet port already installed. Likewise, most fully assembled desktop computers come with an Ethernet NIC adapter as standard equipment. If your computer does not have an Ethernet port, you must install an Ethernet NIC adapter before you can use the Router. If you must install an adapter, follow the installation instructions that come with the Ethernet NIC adapter.

Additional Software

It may be necessary to install software on your computer that enables the computer to access the Internet. Additional software must be installed if you are using the device as a simple bridge. For a bridged connection, the information needed to make and maintain the Internet connection is stored on another computer or gateway device, not in the Router itself.

If your ADSL service is delivered through a PPPoE, PPPoA or Static IP connection, the information needed to establish and maintain the Internet connection can be stored in the Router. In this case, it is not necessary to install software on your computer. It may however be necessary to change some settings in the device, including account information used to identify and verify the connection.

Information you will need from your ADSL service provider:

Username	This is the Username used to log on to your ADSL service provider's network. It is commonly in the form – user@isp.com. Your ADSL service provider uses this to identify your account.	Record info here
Password	This is the Password used, in conjunction with the Username above, to log on to your ADSL service provider's network. This is used to verify the identity of your account.	
Connection and Encapsulation Type	This is the method your ADSL service provider uses to transport data between the Internet and your computer. Most users will use the default PPPoE/PPPoA, connection type. The Setup Wizard can be used to configure a PPPoE/PPPoA connection type. You may need to specify one of the following connection types (PPPoE LLC, PPPoA LLC or PPPoA VC-MUX). The other available connection and encapsulation combinations must be configured using the web manager. These include Bridge Mode (1483 Bridged IP LLC or 1483 Bridged IP VC-MUX), and Static IP (Bridged IP LLC, 1483 Bridged IP VC-MUX, 1483 Routed IP LLC, 1483 Routed IP VC-MUX or IPoA).	
VPI	Most users will not be required to change this setting. The Virtual Path Identifier (VPI) is used in conjunction with the Virtual Channel Identifier (VCI) to identify the data path between your ADSL service provider's network and your computer. If you are setting up the Router for multiple virtual connections, you will need to configure the VPI and VCI as instructed by your ADSL service provider for the additional connections. This setting can be changed in the WAN menu of the web management interface.	
VCI	Most users will not be required to change this setting. The Virtual Channel Identifier (VCI) used in conjunction with the VPI to identify the data path between your ADSL service provider's network and your computer. If you are setting up the Router for multiple virtual connections, you will need to configure the VPI and VCI as instructed by your ADSL service provider for the additional connections. This setting can be changed in the WAN menu of the web management interface.	



Note

The Setup Wizard can be used to configure the Internet connection for most users. If you are using a PPPoE or PPPoA type connection use the Setup Wizard to establish the Internet connection.

Information you will need about your DSL-502T ADSL Router:

Username	This is the Username needed access the Router's management interface. When you attempt to connect to the device through a web browser you will be prompted to enter this Username. The default Username for the Router is admin . The user cannot change this.	Record info here
Password	This is the Password you will be prompted to enter when you access the Router's management interface. The default Password is admin . The user may change this.	
LAN IP addresses for the DSL-502T	This is the IP address you will enter into the Address field of your web browser to access the Router's configuration graphical user interface (GUI) using a web browser. The default IP address is 10.1.1.1 and it is referred to as the "Management IP" address in this User's Manual. This may be changed to suit any IP address scheme the user desires. This address will be the base IP address used for DHCP service on the LAN when DHCP is enabled.	
LAN Subnet Mask for the DSL-502T	This is the subnet mask used by the DSL-502T, and will be used throughout your LAN. The default subnet mask is 255.0.0.0 . This can be changed later.	

Information you will need about your LAN or computer:

Ethernet NIC	If your computer has an Ethernet NIC, you can connect the DSL-502T to this Ethernet port using an Ethernet cable. You can also use the Ethernet ports on the DSL-502T to connect to other computer or Ethernet devices.	Record info here
DHCP Client status	Your DSL-502T ADSL Router is configured, by default, to be a DHCP server. This means that it can assign an IP address, subnet mask, and a default gateway address to computers on your LAN. The default range of IP addresses the DSL-502T will assign are from 10.1.1.2 to 10.1.1.254 . Your computer (or computers) needs to be configured to Obtain an IP address automatically (that is, they need to be configured as DHCP clients.)	

It is recommended that you collect and record this information here, or in some other secure place, in case you have to re-configure your ADSL connection in the future.

Once you have the above information, you are ready to setup and configure your DSL-502T ADSL Router.

Installing the USB Driver

IMPORTANT: Do not connect the USB cable to your PC before completing the below steps.

The CD-ROM shipped with the Router contains the USB driver software.



Insert DSL-502T CD-ROM into the CD-ROM drive. Within a few seconds you should see the dialog box shown below. If you do not see the auto-run dialog box shown below, explore the CD-ROM and double-click the setup application file **autorun.exe** or find the file **Setup.exe** in the folder labeled **USBDRIVER** and double-click it to launch the installation software. The auto-run USB driver setup must be completed before connecting the router to your PC with the USB cable. To install the driver follow these instructions:

1. Click the **Install DSL-502T** link to launch the USB driver installation software.

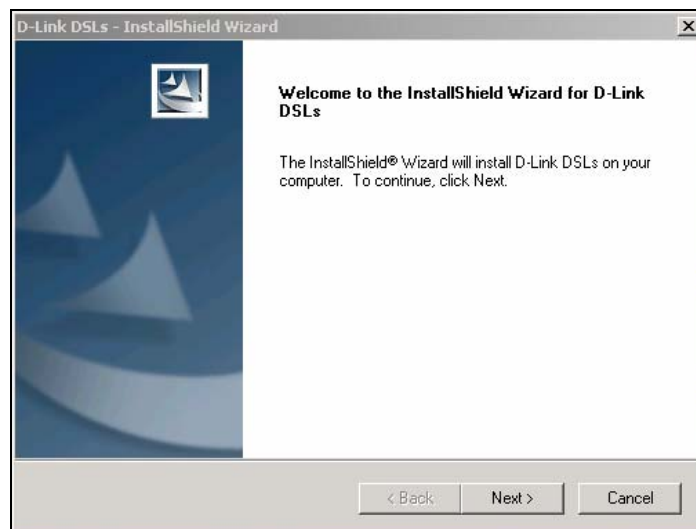

2. Click **Next** on the InstallShield dialog box.

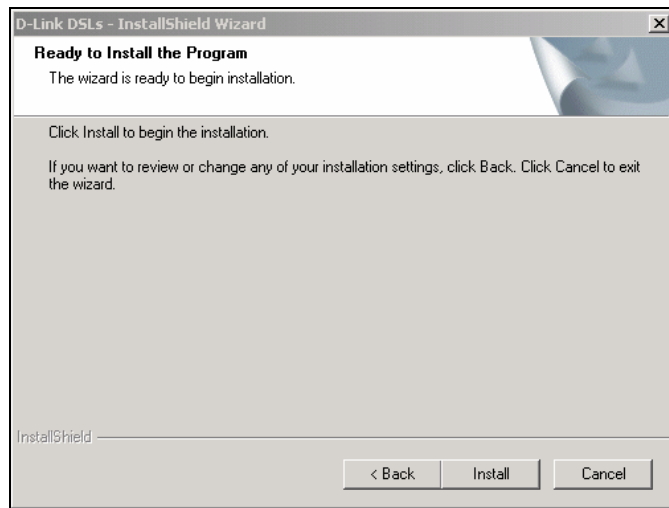

3. Click **Install** to begin the installation.

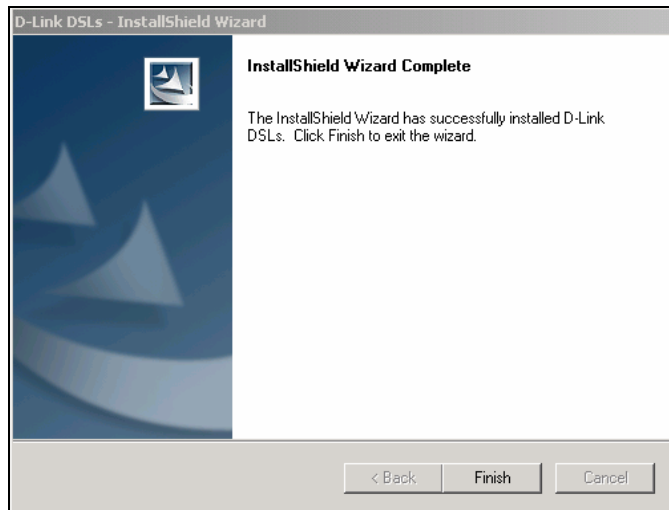

4. Click **Finish** to complete the InstallShield wizard.

When the USB driver has been installed, insert one end of the USB cable included with the router into the DSL-502T router's USB port. Insert the other end of the USB cable into a USB port on your PC. Connect the power adapter to the power input at the back panel of the DSL-502T and then plug the other end of the power adapter to a wall outlet or power strip. On the front of the device, the Power LED will turn ON to indicate proper operation. Insert the telephone cable included with the Router into the ADSL port, and then connect the cable to your telephone line. Check the LED display on the front of the Router to confirm that the connections have been made.



Introduction

This section provides a brief description of the Router, its associated technologies and a list of Router features.

Router Description and Operation

The DSL-502T Router is designed to provide a simple and cost-effective ADSL Internet connection for a private Ethernet network. The Router combines high-speed ADSL Internet connection, IP routing management for the LAN in one package.

The Router is easy to install and use. The DSL-502T connects to an Ethernet LAN or computers via standard Ethernet ports. The ADSL connection is made using ordinary telephone line with standard connectors. Multiple workstations can be networked and connected to the Internet using a single Wide Area Network (WAN) interface and single global IP address. The advanced security enhancements, packet filtering and port redirection, can help protect your network from potentially devastating intrusions by malicious agents from outside your network.

ADSL

Asymmetric Digital Subscriber Line (ADSL) is a broadband network technology that utilizes standard twisted-pair copper wire telephone lines to enable broadband high-speed digital data transmission and bandwidth hungry applications for business and residential customers.

ADSL routers and modems provide faster downloads and more reliable connectivity to the user without loss of quality or disruption of voice/fax telephone capabilities.

ADSL service operates at speeds of up to 8 Mbps downstream and up to 640 Kbps upstream. A secure dedicated point-to-point connection is established between the user and the central office of the service provider.

Router Features

The DSL-502T ADSL Router utilizes the latest ADSL enhancements to provide a reliable Internet portal suitable for most small to medium sized offices. DSL-502T advantages include:

- **PPP (Point-to-Point Protocol) Security** – The DSL-502T ADSL Router supports PAP (Password Authentication Protocol) and CHAP (Challenge Handshake Authentication Protocol) for PPP connections.
- **DHCP Support** – Dynamic Host Configuration Protocol automatically and dynamically assigns all LAN IP settings to each host on your network. This eliminates the need to reconfigure every host whenever changes in network topology occur.
- **Network Address Translation (NAT)** – For small office environments, the DSL-502T allows multiple users on the LAN to access the Internet concurrently through a single Internet account. This provides Internet access to everyone in the office for the price of a single user.

NAT improves network security in effect by hiding the private network behind one global and visible IP address. NAT address mapping can also be used to link two IP domains via a LAN-to-LAN connection.

- **TCP/IP (Transfer Control Protocol/Internet Protocol)** – The DSL-502T supports TCP/IP protocol, the language used for the Internet. It is compatible with access servers manufactured by major vendors.
- **RIP-1/RIP-2** – The DSL-502T supports both RIP-1 and RIP-2 exchanges with other routers. Using both versions lets the Router to communicate with all RIP enabled devices.
- **Static Routing** – This allows you to select a data path to a particular network destination that will remain in the routing table and never “age out”. If you wish to define a specific route that will always be used for data traffic from your LAN to a specific destination within your LAN (for example to another router or a server) or outside your network (to an ISP defined default gateway for instance).
- **Default Routing** – This allows you to choose a default path for incoming data packets for which the destination address is unknown. This is particularly useful when/if the Router functions as the sole connection to the Internet.
- **ATM (Asynchronous Transfer Mode)** – The DSL-502T supports Bridged Ethernet over ATM (RFC1483), IP over ATM (RFC1577) and PPP over ATM (RFC 2364).
- **Precise ATM Traffic Shaping** – Traffic shaping is a method of controlling the flow rate of ATM data cells. This function helps to establish the Quality of Service for ATM data transfer.
- **G.hs (Auto-handshake)** – This allows the Router to automatically choose either the G.lite or G.dmt ADSL connection standards.
- **High Performance** – Very high rates of data transfer are possible with the Router. Up to 8 Mbps downstream bit rate using the G.dmt standard.
- **Full Network Management** – The DSL-502T incorporates SNMP (Simple Network Management Protocol) support for web-based management and text-based network management via an RS-232 or Telnet connection.
- **Telnet Connection** – The Telnet enables a network manager to access the Router's management software remotely.
- **Easy Installation** – The DSL-502T uses a web-based graphical user interface program for convenient management access and easy set up. Any common web browser software can be used to manage the Router.

Standards Compatibility and Compliance

The DSL-502T complies with or is compatible with the following standards as recognized by their respective agencies.

- ITU G.992.2 (G.lite) compliant
- ITU-T Rec. I.361 compliant
- RFC 791 Internet Protocol compliant
- RFC 792 UDP compliant
- RFC 826 Address Resolution Protocol compliant (ARP) compliant
- RFC 1058 Routing Information Protocol (RIP) compliant
- RFC 1213 MIB II for IP compliant
- RFC 1334 PPP Authentication Protocol compliant
- RFC 1389 Routing Information Protocol 2 (RIP2) compliant
- RFC 1483 IP over AAL5/ Bridged Ethernet over AAL5 compliant
- RFC 1557 Classical IP over ATM (IPoA) compliant
- RFC 1661 Point to Point Protocol (PPP) compliant
- RFC 1877 Automatic IP assignment compliant
- RFC 1994 Challenge Handshake Authentication Protocol compliant
- Supports RFC 2131 and RFC 2132 DHCP functions including: automatic assignment of IP address, use of subnet mask and default gateway and provision of DNS server address for all hosts
- RFC 2364 PPP over ATM compliant (PPPoA) compliant
- RFC 2516 PPP over Ethernet compliant (PPPoE) compliant
- RFC 2684 Bridged/Routed Ethernet over ATM compliant
- IEEE 802.3 compliant
- IEEE 802.3u compliant
- IEEE 802.1d compliant
- IEEE 802.11g compliant
- IEEE 802.3x compliant
- Embedded web server support
- Supports Dynamic Learning
- Supports Static Routing
- Supports NAT for up to 4096 connections
- Supports DHCP for up to 253 hot connections
- Supports IGMP
- Supports ATM Forum UNI 3.1/4.0
- Supports ATM VCC (Virtual Channel Circuit) for up to eight sessions
- Supports TELNET and TFTP
- Supports back pressure for half-duplex

Front Panel Display

Place the Router in a location that permits an easy view of the LED indicators on the front panel.

The LED indicators on the front panel include the **Power**, **Status**, **ADSL Link/Act**, **Ethernet Link/Act**, and **USB Link/Act** indicators. The ADSL, Ethernet, and USB indicators monitor link status and activity (Link/Act).

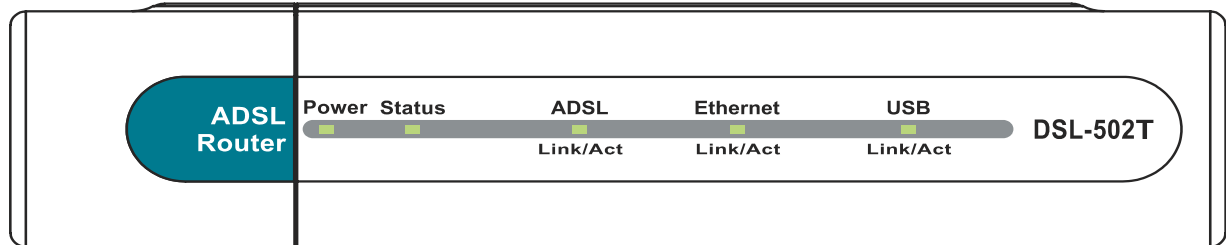

Power	Steady green light indicates the unit is powered on. When the device is powered off this remains dark.
Status	Lights steady green during power on self-test (POST). Once the connection status has been settled, the light will blink green. If the indicator lights steady green after the POST, the system has failed and the device should be rebooted.
ADSL: Link/Act	Steady green light indicates a valid ADSL connection. This will light after the ADSL negotiation process has been settled. A blinking green light indicates activity on the WAN (ADSL) interface.
Ethernet: Link/Act	A solid green light indicates a valid link on startup. This light will blink when there is activity currently passing through the Ethernet port.
USB: Link/Act	Steady green light indicates a valid USB connection. A blinking green light indicates activity on the USB interface.

Rear Panel

All cable connections to the Router are made at the rear panel. The factory-reset button is located here as well.

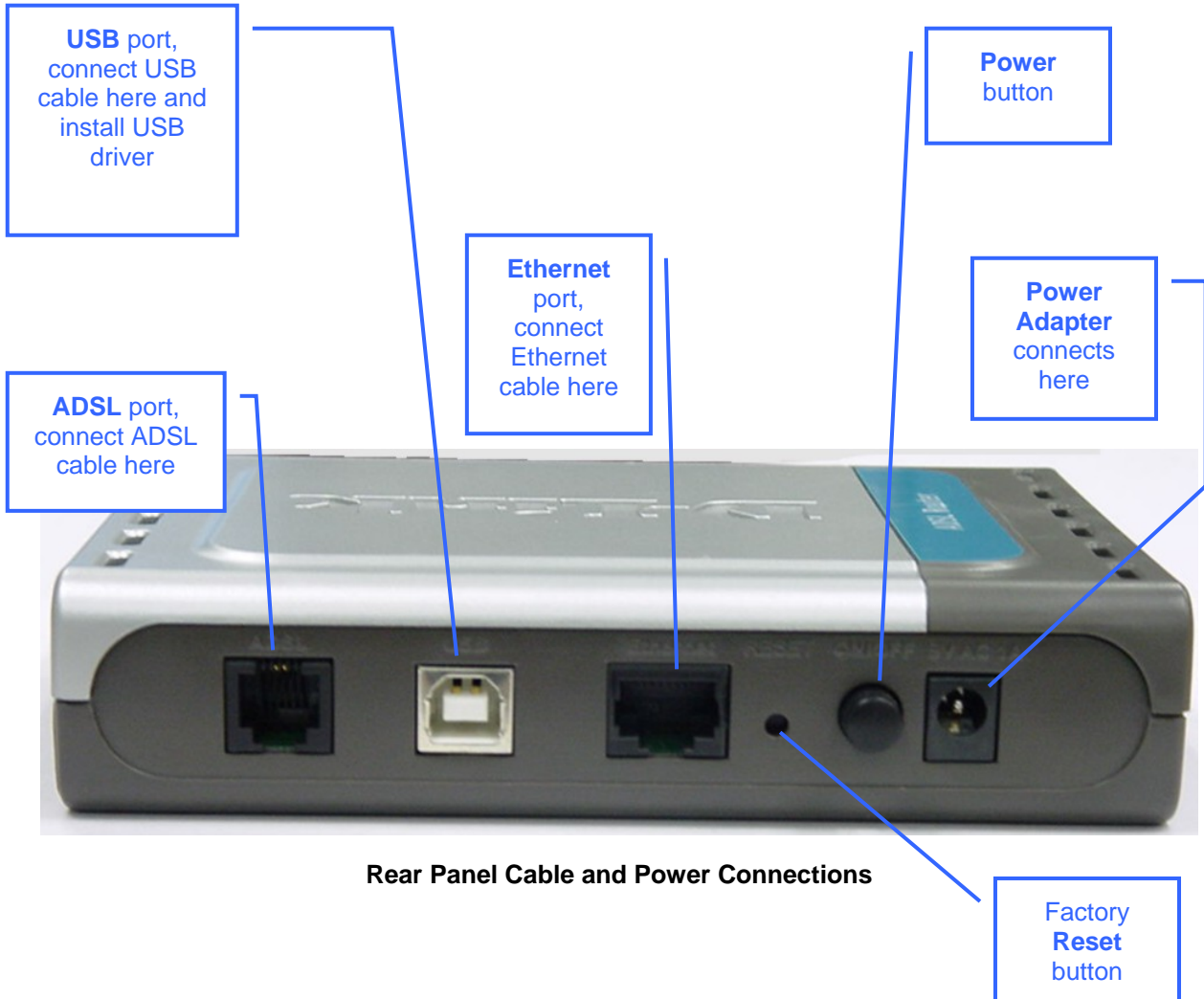

Rear Panel Cable and Power Connections



Note

To manually reboot the Router, toggle the power switch off and on.

Hardware Installation

The DSL-502T maintains three separate interfaces, an Ethernet, a USB and an ADSL interface. Place the Router in a location where it can be connected to the various devices as well as to a power source. The Router should not be located where it will be exposed to moisture or excessive heat. Make sure the cables and power cord are placed safely out of the way so they do not create a tripping hazard. As with any electrical appliance, observe common sense safety procedures.

The Router can be placed on a shelf or desktop, ideally you should be able to see the LED indicators on the front if you need to view them for troubleshooting.

Power on Router



CAUTION: The Router must be used with the power adapter included with the device.

To power on the Router:

1. Insert the AC Power Adapter cord into the power receptacle located on the rear panel of the Router and plug the adapter into a suitable nearby power source.
2. You should see the Power LED indicator light up and remain lit. The Status LED should light solid green and begin to blink after a few seconds.
3. If the Ethernet port is connected to a working device, check the Ethernet Link/Act LED indicators to make sure the connection is valid. The Router will attempt to establish the ADSL connection, if the ADSL line is connected and the Router is properly configured this should light up after several seconds. If this is the first time installing the device, some settings may need to be changed before the Router can establish a connection.

Factory Reset Button

The Router may be reset to the original factory default settings by depressing the reset button for a few seconds while the device is powered on. Use a ballpoint or paperclip to gently push down the reset button. Remember that this will wipe out any settings stored in flash memory including user account information and LAN IP settings. The device settings will be restored to the factory default IP address 10.1.1.1 and the subnet mask is 255.0.0.0, the default management Username is **admin** and the default Password is **admin**.

Network Connections

Network connections are provided through the ADSL port, the Ethernet port and the USB port on the back of the Router. See the Rear Panel diagram above and the illustrations below for examples. See Installing the USB Driver above for a description of the USB driver installation procedure.

Connect ADSL Line

Use the ADSL cable included with the Router to connect it to a telephone wall socket or receptacle. Plug one end of the cable into the ADSL port (RJ-11 receptacle) on the rear panel of the Router and insert the other end into the RJ-11 wall socket. If you are using a low pass filter device, follow the instructions included with the device or given to you by your service provider. The ADSL connection

represents the WAN interface, the connection to the Internet. It is the physical link to the service provider's network backbone and ultimately to the Internet.

Connect Router to Ethernet

The Router may be connected to a single computer or Ethernet device through the 10/100 BASE-TX Ethernet port on the rear panel. Any connection to an Ethernet concentrating device such as a switch or hub must operate at a speed of 10/100 Mbps only. When connecting the Router to any Ethernet device that is capable of operating at speeds between 0~100Mbps, be sure that the device has auto-negotiation (NWay) enabled for the connecting port.

Use standard twisted-pair cable with RJ-45 connectors. The RJ-45 port on the Router is a crossed port (MDI-X). Follow standard Ethernet guidelines when deciding what type of cable to use to make this connection. When connecting the Router directly to a PC or server use a normal straight-through cable. You should use a crossed cable when connecting the Router to a normal (MDI-X) port on a switch or hub. Use a normal straight-through cable when connecting it to an uplink (MDI-II) port on a hub or switch.

The rules governing Ethernet cable lengths apply to the LAN to Router connection. Be sure that the cable connecting the LAN to the Router does not exceed 100 metres.

Hub or Switch to Router Connection

Connect the Router to an uplink port (MDI-II) on an Ethernet hub or switch with a straight-through cable as shown in the diagram below:

If you wish to reserve the uplink port on the switch or hub for another device, connect to any on the other MDI-X ports (1x, 2x, etc.) with a crossed cable.

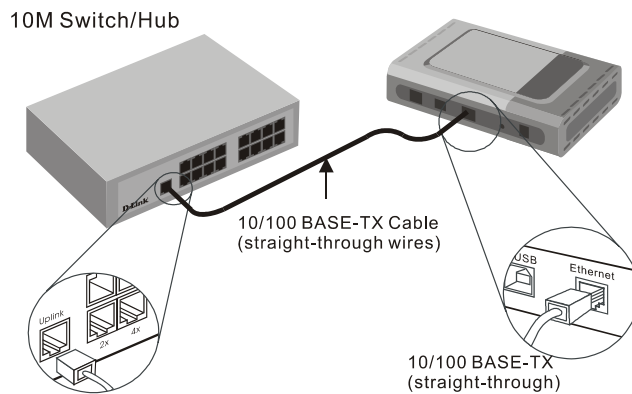

Computer to Router Connection

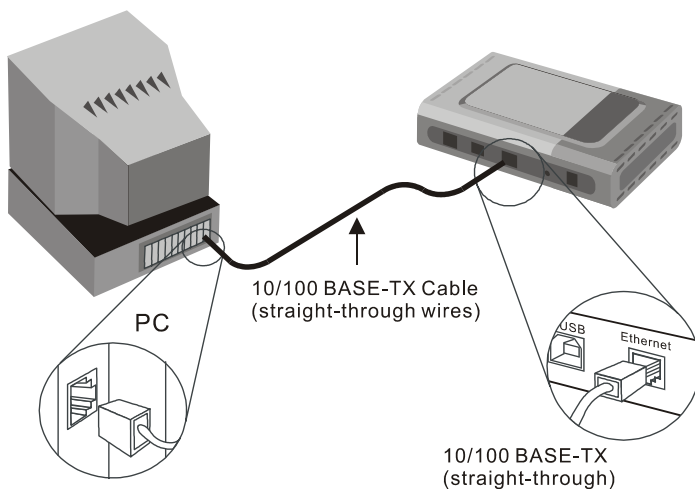

You can connect the Router directly to a 10/100BASE-TX Ethernet adapter card (NIC) installed on a PC using the Ethernet cable provided as shown in this diagram.

Basic Router Configuration

The first time you setup the Router it is recommended that you configure the WAN connection using a single computer making sure that both the computer and the Router are not connected to the LAN. Once the WAN connection is functioning properly, you may continue to make changes to Router configuration including IP settings and DHCP setup. This chapter is concerned with using your computer to configure the WAN connection. The following chapter describes the various menus used to configure and monitor the Router including how to change IP settings and DHCP server setup.

Wan Configuration Summary

1. **Connect to the Router** To configure the WAN connection used by the Router it is first necessary to communicate with the Router through its management interface, which is HTML-based and can be accessed using a web browser. To access the management software your computer must be able to “see” the Router. Your computer can see the Router if it is in the same “neighborhood” or subnet as the Router. This is accomplished by making sure your computer has IP settings that place it in the same subnet as the Router. The easiest way to make sure your computer has the correct IP settings is to configure it to use the DHCP server in the Router. The next section describes how to change the IP configuration for a computer running a Windows operating system to be a DHCP client.
2. **Configure the WAN Connection** Once you are able to access the configuration software you can proceed to change the settings required to establish the ADSL connection and connect to the service provider's network. There are different methods used to establish the connection to the service provider's network and ultimately to the Internet. You should know what Encapsulation and connection type you are required to use for your ADSL service. It is also possible that you must change the PVC settings used for the ADSL connection. Your service provider should provide all the information you need to configure the WAN connection.

Configuring IP Settings on Your Computer

In order to configure your system to receive IP settings from the Router it must first have the TCP/IP protocol installed. If you have an Ethernet port on your computer, it probably already has TCP/IP protocol installed. If you are using Windows XP the TCP/IP is enabled by default for standard installations. Below is an illustrated example of how to configure a Windows XP system to automatically obtain IP settings from the Router. Following this example is a step-by-step description of the procedures used on the other Windows operating systems to first check if the TCP/IP protocol has been installed; if it is not, instructions are provided for installing it. Once the protocol has been installed you can configure the system to receive IP settings from the Router.

For computers running non-Windows operating systems, follow the instructions for your OS that configure the system to receive an IP address from the Router, that is, configure the system to be a DHCP client.

**Note**

If you are using this Router to provide Internet access for more than one computer, you can use these instructions later to change the IP settings for the other computers. However, you cannot use the same IP address since every computer must have its own IP address that is unique on the local network.

Configure Windows XP for DHCP

Use the following steps to configure a computer running Windows XP to be a DHCP client.

1. From the **Start** menu on your desktop, go to **Settings**, then click on **Network Connections**.

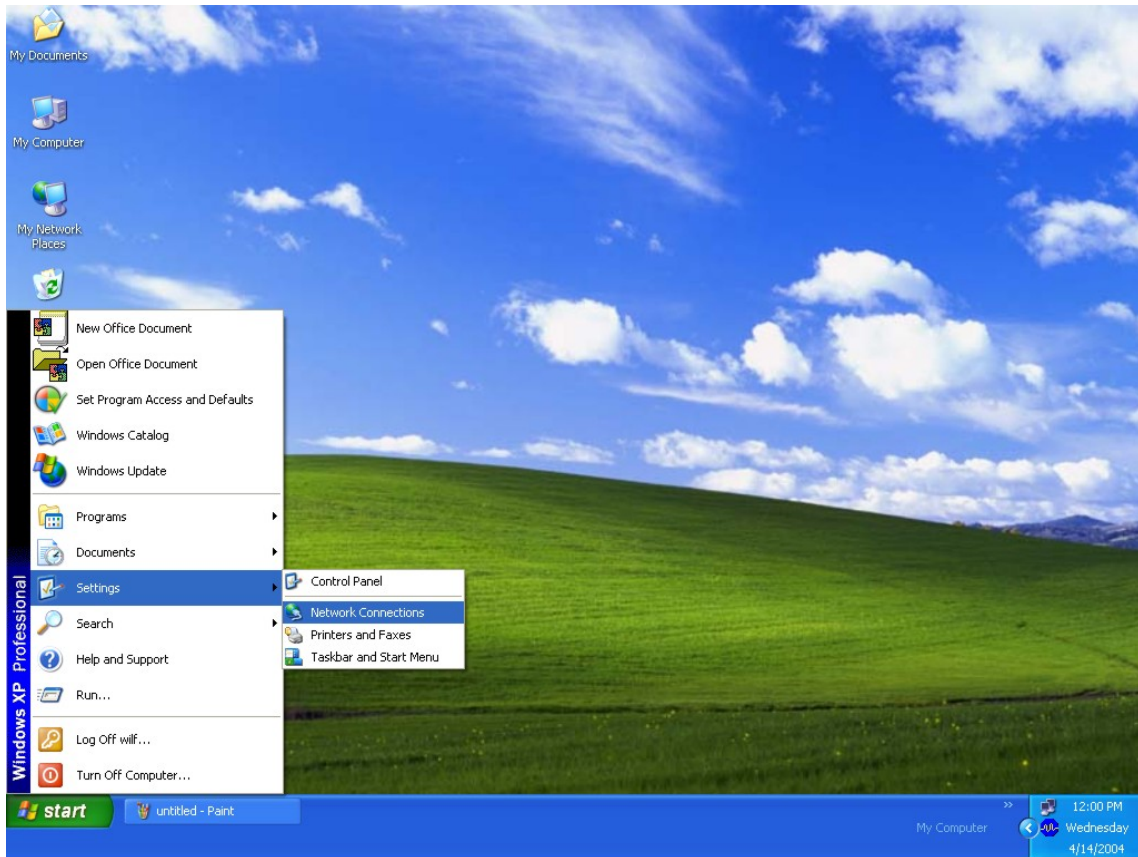

In the **Network Connections** window, right-click on **LAN** (Local Area Connection), then click **Properties**.

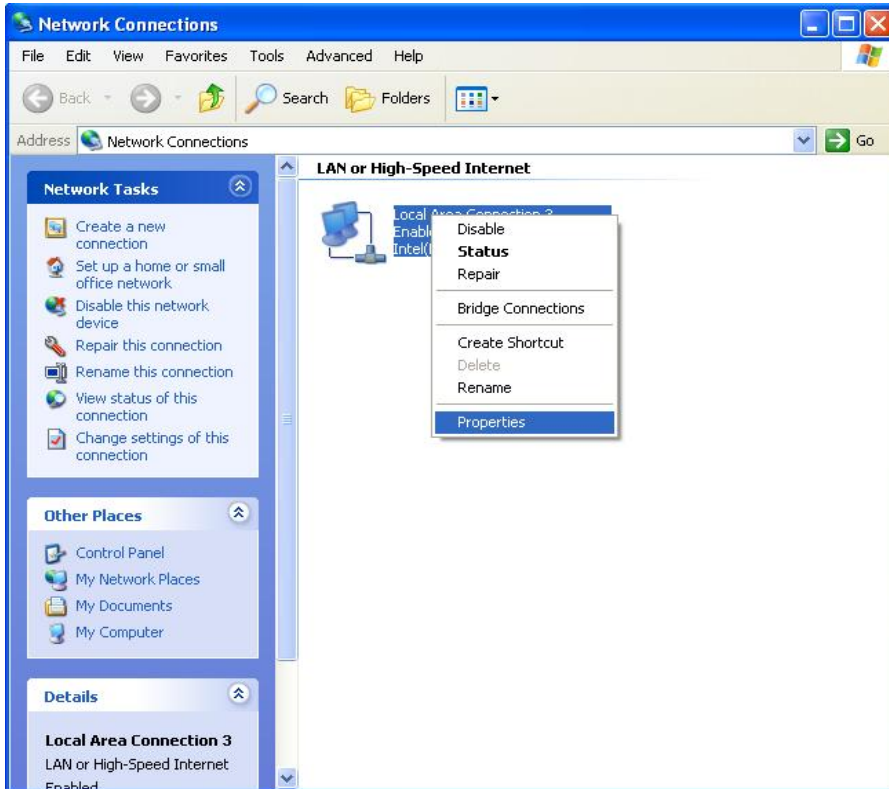

2. In the **General** tab of the **Local Area Connection Properties** menu, highlight **Internet Protocol (TCP/IP)** under "This connection uses the following items:" by clicking on it once. Click on the **Properties** button.

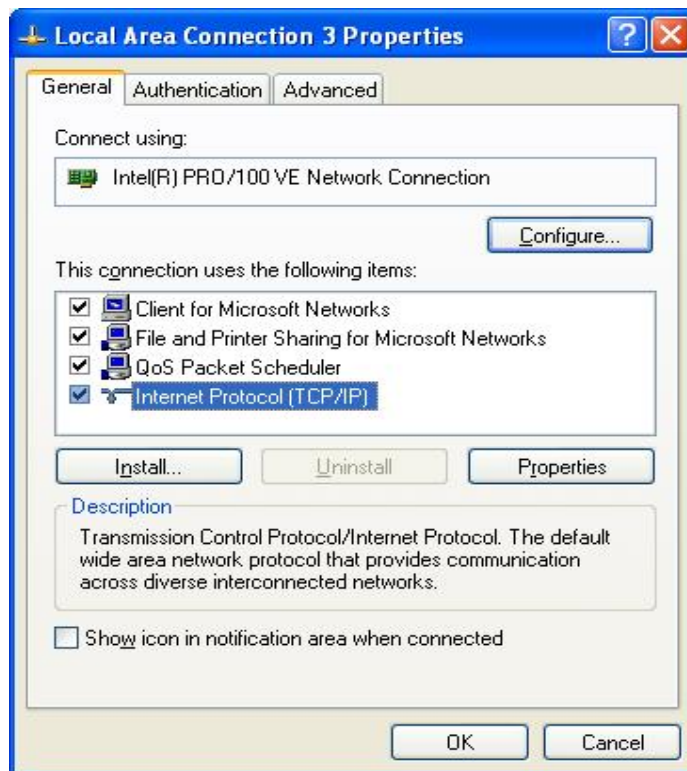

3. Select "Obtain an IP address automatically" by clicking once in the circle. Click the **OK** button.

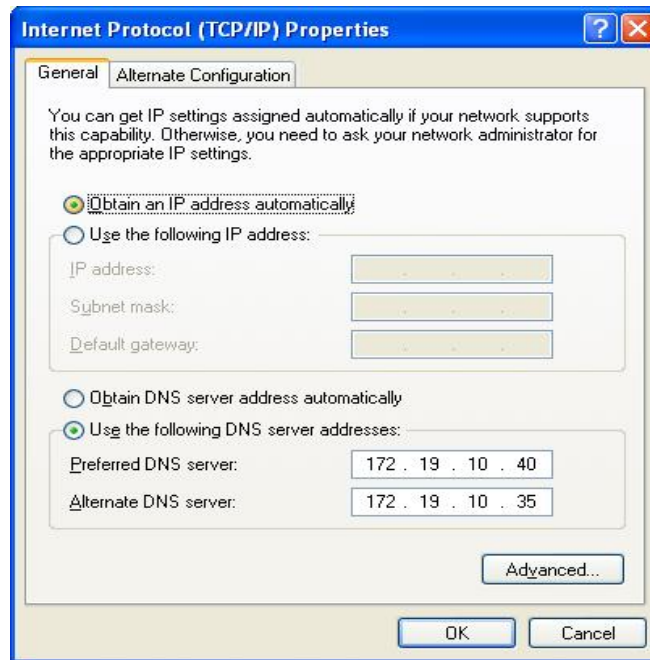

Your computer is now ready to use the Router's DHCP server.

Windows 2000

First, check for the IP protocol and, if necessary, install it:

1. In the **Windows** task bar, click the **Start** button, point to **Settings**, and then click **Control Panel**.
2. Double-click the **Network and Dial-up Connections** icon.
3. In the **Network and Dial-up Connections** window, right-click the **Local Area Connection** icon, and then select **Properties**.
4. The **Local Area Connection Properties** dialog box displays with a list of currently installed network components. If the list includes Internet Protocol (TCP/IP), then the protocol has already been enabled, skip ahead to *Configure Windows 2000 for DHCP*.
5. If Internet Protocol (TCP/IP) does not display as an installed component, click **Install**.
6. In the **Select Network Component Type** dialog box, select **Protocol**, and then click **Add**.
7. Select **Internet Protocol (TCP/IP)** in the Network Protocols list, and then click **OK**.
8. You may be prompted to install files from your Windows 2000 installation CD or other media. Follow the instructions to install the files.
9. If prompted, click **OK** to restart your computer with the new settings.

Configure Windows 2000 for DHCP

1. In the Control Panel, double-click the **Network and Dial-up Connections** icon.
2. In **Network and Dial-up Connections** window, right-click the **Local Area Connection** icon, and then select **Properties**.
3. In the **Local Area Connection Properties** dialog box, select **Internet Protocol (TCP/IP)**, and then click **Properties**.
4. In the **Internet Protocol (TCP/IP) Properties** dialog box, click the button labeled **Obtain an IP address automatically**.
5. Double-click **OK** to confirm and save your changes, and then close the Control Panel.

Your computer is now ready to use the Router's DHCP server.

Windows ME

First, check for the IP protocol and, if necessary, install it:

1. In the **Windows** task bar, click the **Start** button, point to **Settings**, and then click **Control Panel**.
2. Double-click the **Network and Dial-up Connections** icon.
3. In the **Network and Dial-up Connections** window, right-click the **Network** icon, and then select **Properties**.
4. The **Network Properties** dialog box displays with a list of currently installed network components. If the list includes Internet Protocol (TCP/IP), then the protocol has already been enabled. Skip ahead to *Configure Windows ME for DHCP*.
5. If Internet Protocol (TCP/IP) does not display as an installed component, click **Add**.
6. In the **Select Network Component Type** dialog box, select **Protocol**, and then click **Add**.
7. Select **Microsoft** in the Manufacturers box.
8. Select **Internet Protocol (TCP/IP)** in the Network Protocols list, and then click **OK**.
9. You may be prompted to install files from your Windows Me installation CD or other media. Follow the instructions to install the files.
10. If prompted, click **OK** to restart your computer with the new settings.

Configure Windows ME for DHCP

1. In the **Control Panel**, double-click the **Network and Dial-up Connections** icon.
2. In the **Network and Dial-up Connections** window, right-click the **Network** icon, and then select **Properties**.
3. In the **Network Properties** dialog box, select **TCP/IP**, and then click **Properties**.
4. In the **TCP/IP Settings** dialog box, click the **Obtain and IP address automatically** option.
5. Double-click **OK** twice to confirm and save your changes, and then close the Control Panel.

Your computer is now ready to use the Router's DHCP server.

Windows 95 and Windows 98

First, check for the IP protocol and, if necessary, install it:

1. In the **Windows** task bar, click the **Start** button, point to **Settings**, and then click **Control Panel**. Double-click the **Network** icon.
2. The **Network** dialog box displays with a list of currently installed network components. If the list includes TCP/IP, and then the protocol has already been enabled, skip to *Configure IP Information Windows 95, 98*.
3. If TCP/IP does not display as an installed component, click **Add**. The **Select Network Component Type** dialog box displays.
4. Select **Protocol**, and then click **Add**. The **Select Network Protocol** dialog box displays.
5. Click on **Microsoft** in the Manufacturers list box, and then click **TCP/IP** in the Network Protocols list box.
6. Click **OK** to return to the Network dialog box, and then click **OK** again. You may be prompted to install files from your Windows 95/98 installation CD. Follow the instructions to install the files.
7. Click **OK** to restart the PC and complete the TCP/IP installation.

Configure Windows 95 and Windows 98 for DHCP

1. Open the **Control Panel** window, and then click the **Network** icon.
2. Select the network component labeled TCP/IP, and then click **Properties**.
3. If you have multiple TCP/IP listings, select the listing associated with your network card or adapter.
4. In the **TCP/IP Properties** dialog box, click the **IP Address** tab.
5. Click the **Obtain an IP address automatically** option.
6. Double-click **OK** to confirm and save your changes. You will be prompted to restart Windows.
7. Click **Yes**.

When it has restarted, your computer is ready to use the Router's DHCP server.

Windows NT 4.0 Workstations

First, check for the IP protocol and, if necessary, install it:

1. In the **Windows NT** task bar, click the **Start** button, point to **Settings**, and then click **Control Panel**.
2. In the **Control Panel** window, double-click the **Network** icon.
3. In the **Network** dialog box, click the **Protocols** tab.
4. The **Protocols** tab displays a list of currently installed network protocols. If the list includes TCP/IP, then the protocol has already been enabled. Skip to "Configure IP Information"
5. If TCP/IP does not display as an installed component, click **Add**.
6. In the **Select Network Protocol** dialog box, select **TCP/IP**, and then click **OK**. You may be prompted to install files from your Windows NT installation CD or other media. Follow the instructions to install the files.
7. After all files are installed, a window displays to inform you that a TCP/IP service called DHCP can be set up to dynamically assign IP information.
8. Click **Yes** to continue, and then click **OK** if prompted to restart your computer.

Configure Windows NT 4.0 for DHCP

1. Open the **Control Panel** window, and then double-click the **Network** icon.
2. In the **Network** dialog box, click the **Protocols** tab.
3. In the **Protocols** tab, select **TCP/IP**, and then click **Properties**.
4. In the **Microsoft TCP/IP Properties** dialog box, click the **Obtain an IP address automatically** option.
5. Click **OK** twice to confirm and save your changes, and then close the Control Panel.

Access the Configuration Manager

Now that your computer's IP settings allow it to communicate with the Router, you can access the configuration software.



Note

Be sure that the web browser on your computer is not configured to use a proxy server in the Internet settings. In Windows Internet Explorer, you can check if a proxy server is enabled using the following procedure:

1. In Windows, click on the **Start** button, go to **Settings** and choose **Control Panel**.
2. In the **Control Panel** window, double-click on the **Internet Options** icon.
3. Click the **Connections** tab and click on the **LAN Settings** button.
4. Verify that the "Use proxy server" option is **NOT** checked. If it is checked, click in the checked box to deselect the option and click **OK**.

*Alternatively, you can access this **Internet Options** menu using the **Tools** pull-down menu in Internet Explorer.*

Login to Home Page

To use the web-based management software, launch a suitable web browser and direct it to the IP address of the Router. Type in **http://** followed by the default IP address, **10.1.1.1** in the address bar of the browser. The URL in the address bar should read: **http://10.1.1.1**.

A dialog box prompts for the User Name and Password. Type in the default User Name **admin** and default Password **admin** and click the **OK** button to access the web-based manager.



The image shows a Windows-style dialog box titled "Connect to 10.1.1.1". It features a blue header with a question mark and a close button. Below the header is a yellow background with a key icon. The text "DSL-502T Admin Login" is centered. There are two input fields: "User name:" with a dropdown menu showing "admin" and a "Password:" field. Below the password field is a checkbox labeled "Remember my password". At the bottom are "OK" and "Cancel" buttons.

Enter Password

You should change the web-based manager access user name and password once you have verified that a connection can be established. The user name and password allows any PC within the same subnet as the Router to access the web-based manager.



Note

Do not confuse the user name and password used to access the web-based manager with the ADSL account user name and password needed for PPP connections to access the Internet.

Configure the Router

When you successfully connect to the web manager, the **Home** directory tab will display the **Setup Wizard** menu. You can launch the Setup Wizard from this page or use the menu buttons located in the left panel of the web page to view other menus used for basic configuration. You may use the Setup Wizard if your Internet connection is a PPPoE connection. If you are using a PPPoE and connection and want to use the Setup Wizard, follow the instructions below. If your Internet connection is a Bridge or Static IP type connection, you should follow the instructions below in the section **Configure WAN Connection**.

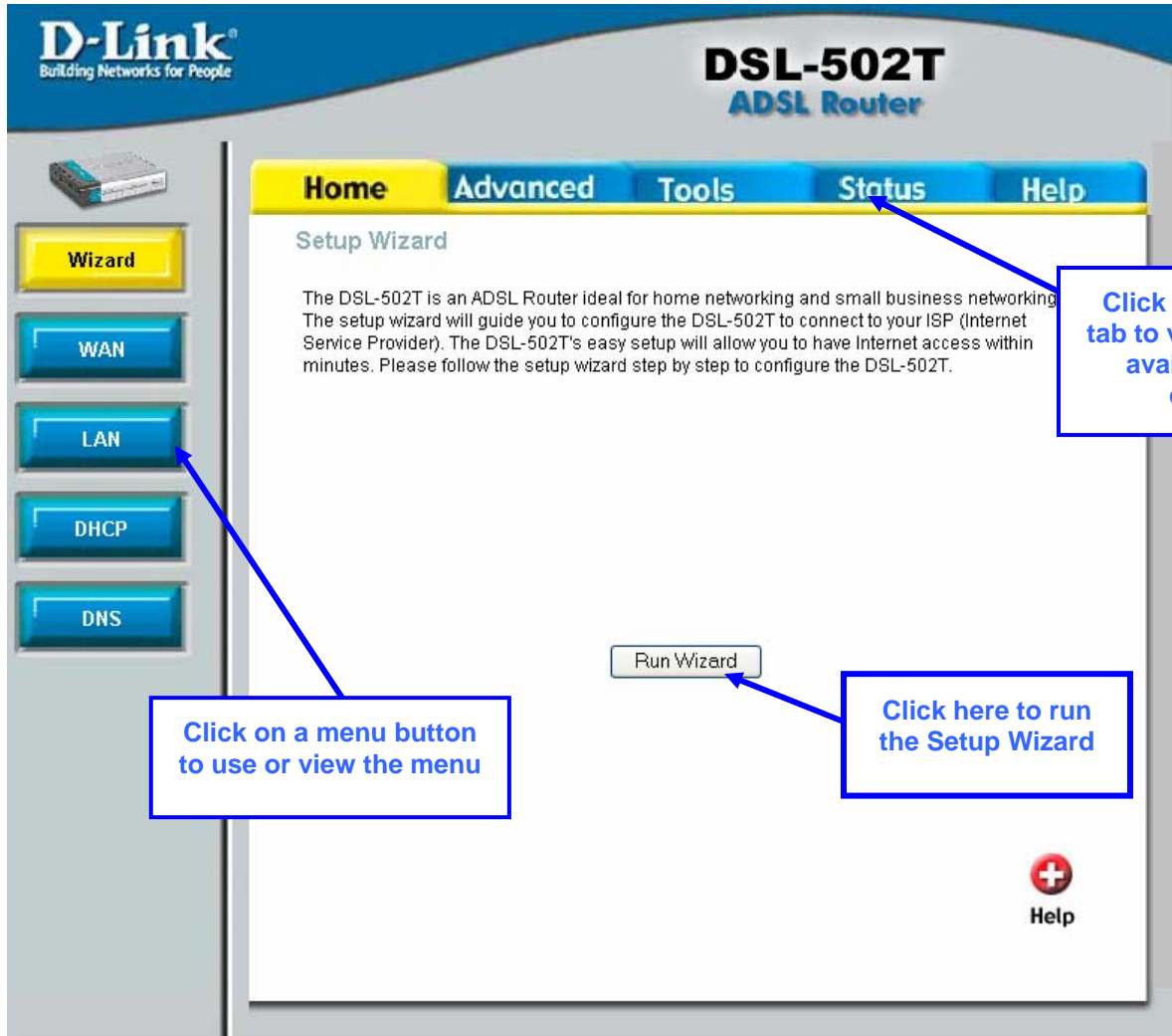

Web Manager – First Time Log On

All configuration and management of the Router is done using the web-based management interface pictured in the above example. The various menus accessed by clicking on one of the directory tabs, Home, Advanced, Tools, Status and Help. Each tab displays menu buttons located in the left hand panel of the web interface. The table below lists the menus for each directory in the web manager.

Directory	Configuration and Read-only Menus
Home	Click the Home tab to access the Setup Wizard, WAN Configuration, LAN IP Configuration, DHCP for the LAN Setup and DNS Configuration menus.
Advanced	Click the Advanced tab to access the UPnP, Port Forwarding, DMZ, IP/MAC Filters, Firewall, NAT, ATM, Static Routing, Dynamic Routing (RIP) and Remote Access menus.

Tools	Click the Tools tab to access the Administrator Settings (used to set the system user name and password, backup and load settings), System Time Configuration, Firmware Upgrade, Diagnostic Test and Save & Reboot menus.
Status	Click the Status tab to view the Device Information, DHCP Clients, Event Log, Traffic Statistics and ADSL Status information windows.
Help	The Help menu presents links to pages that explain various functions and services provided by the Router.

Using the Setup Wizard

To use the Setup Wizard, click the **Run Wizard** button in the first browser window and follow the instructions in the pop-up window that appears.

The first window summarizes the setup process. Click the **Next** button to proceed. You may stop using the Setup Wizard at any time by clicking the **Exit** button. If you exit the wizard you will return to the first page without saving any of the settings changed during the process.

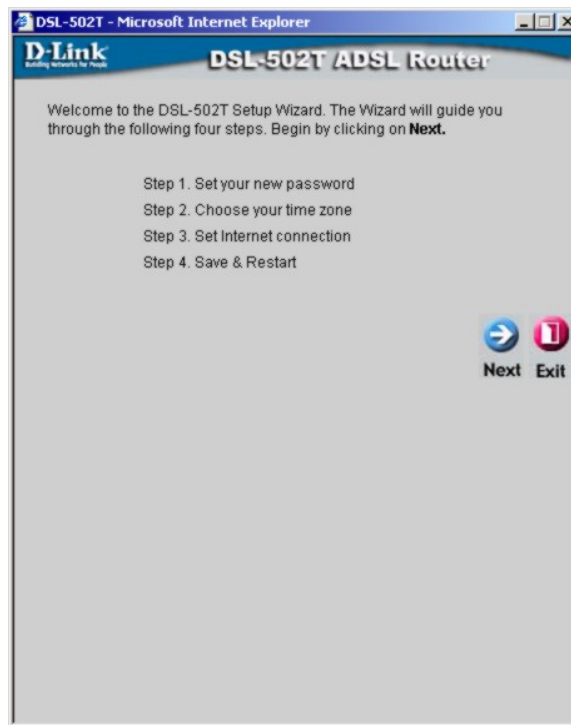

The first window of the Setup Wizard lists the basic steps in the process. These steps are as follows:

1. Set your new system password.
2. Set the system time.
3. Configure the connection to the Internet.
4. Save the new configuration settings and reboot the system.

Set a password that is required to make changes to the configuration settings of the Router in the Advanced Configurations menus. Type in a password and verify it by typing a second time. Click **Next** to continue.

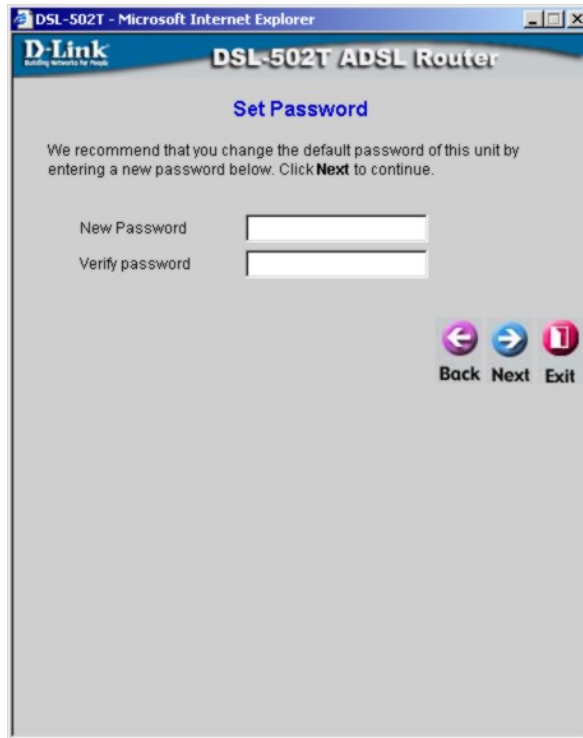

Note

The default User Name **admin** used for Router management cannot be changed.

Set the system time of the Router. Choose the time zone you are in from the pull-down menu and click **Next**. If you wish to return to the previous menu during the setup process, click the **Back** button.

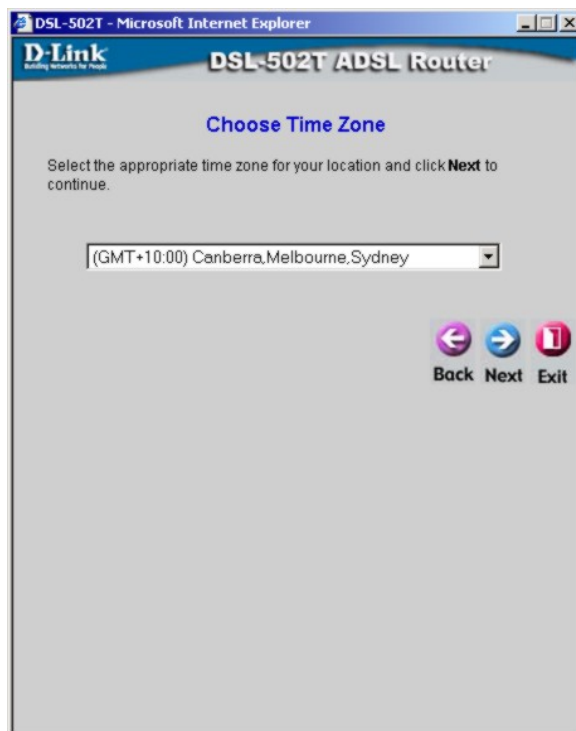

Now select the Connection Type for the Internet and enter your account User Name and Password. Your ISP has given this information to you. The connection types available in the Setup Wizard

menu are PPPoE LLC, PPPoA LLC and PPPoA VC-MUX. For Bridge Mode and Static IP connections, use the WAN menu in the Home directory to configure the connection (see below for instruction on setting up Bridge and Static IP connections).

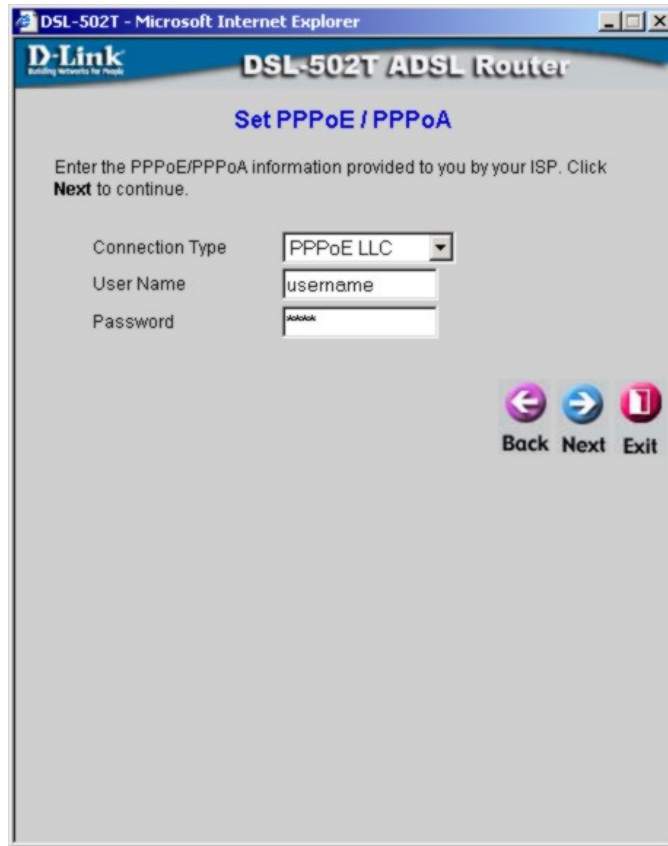

1. Select the **Connection Type** specific to your service. The choices available in the Setup Wizard are *PPPoE LLC*, *PPPoA LLC* and *PPPoA VC-MUX*
2. Type in the **Username** and **Password** used to identify and verify your account to the ISP.
3. Click **Next** to go to the next menu and complete the setup wizard.



Note

If your service provider has instructed you to change the VPI or VCI value for your ADSL connection, use the Home > WAN menu to change these.

Finally you can confirm that the setup process is completed. If you are satisfied that you have entered all the necessary information correctly, click the **Restart** button to save the new configuration settings and restart the Router. If you need to change settings from a previous menu, click the **Back** button.

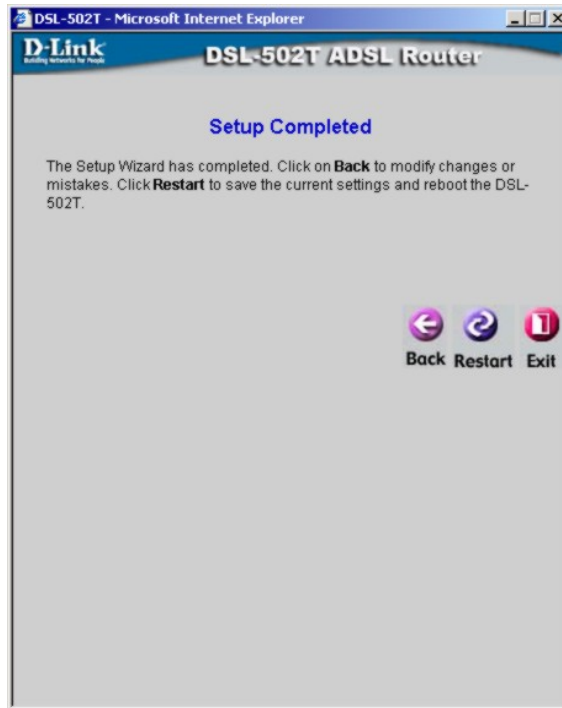

Do not turn the Router off while it is restarting. When it is finished rebooting, click **Close** to close the box and continue to configure the Router as desired.

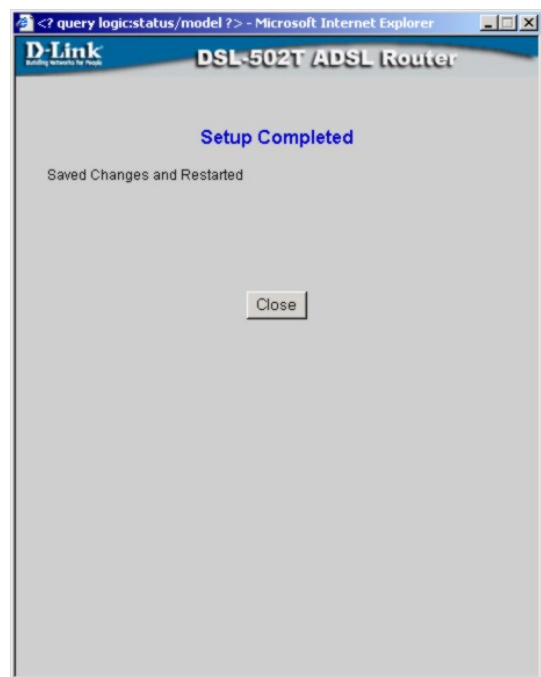
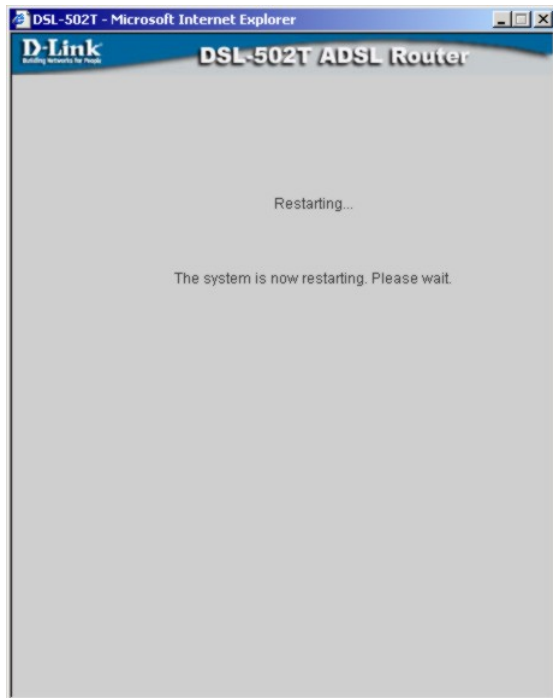

Configure WAN Connection

To configure the Router's basic configuration settings without running the Setup Wizard, you can access the menus used to configure WAN, LAN, DHCP and DNS settings directly from the **Home** directory. To access the WAN Settings menu, click on the **WAN** link button on the left side of the first window that appears when you successfully access the web manager.

The WAN Settings menu is also used to configure the Router for multiple virtual connections (Multiple PVCs). The next chapter contains a section describing how to set up multiple PVCs on the Router.

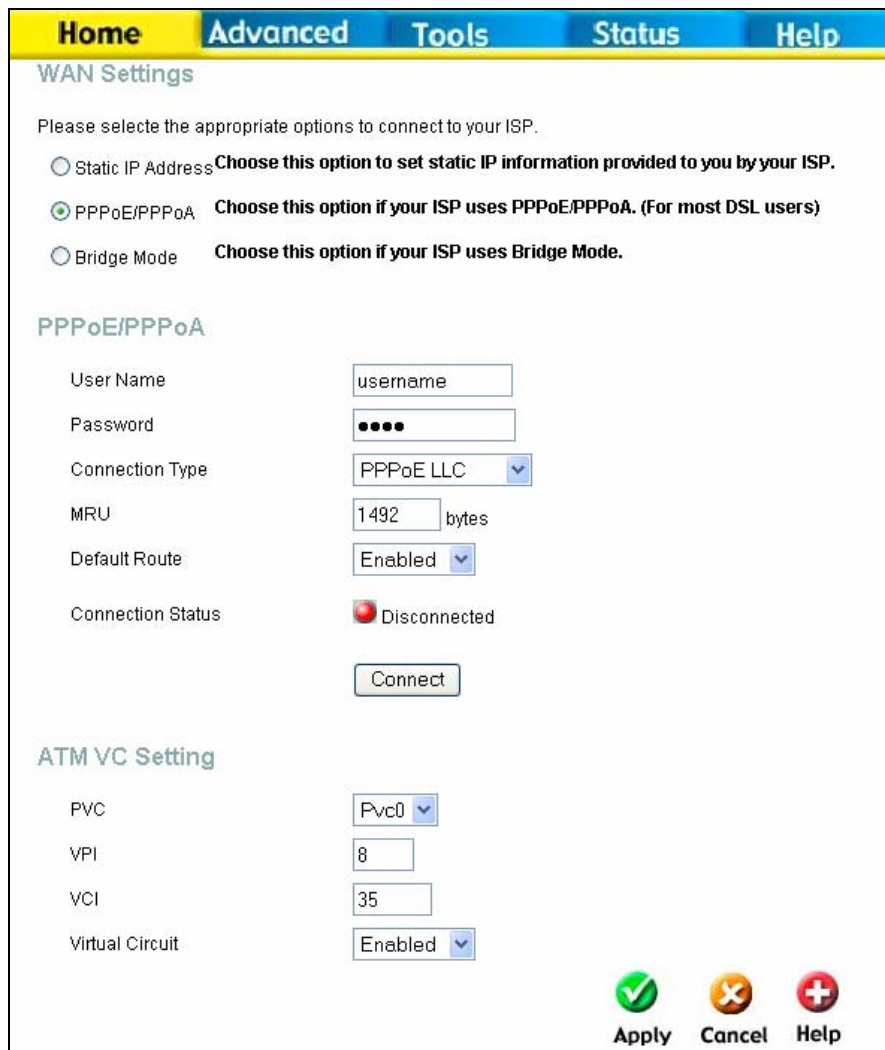

Home **Advanced** **Tools** **Status** **Help**

WAN Settings

Please select the appropriate options to connect to your ISP.

Static IP Address **Choose this option to set static IP information provided to you by your ISP.**
 PPPoE/PPPoA **Choose this option if your ISP uses PPPoE/PPPoA. (For most DSL users)**
 Bridge Mode **Choose this option if your ISP uses Bridge Mode.**

PPPoE/PPPoA

User Name:
 Password:
 Connection Type:
 MRU: bytes
 Default Route:
 Connection Status: Disconnected

ATM VC Setting

PVC:
 VPI:
 VCI:
 Virtual Circuit:

Apply Cancel Help

WAN Settings Menu – PPPoE / PPPoA

Select the connection type used for your account. The menu will display settings that are appropriate for the connection type you select. Follow the instruction below according to the type of connection you select in the WAN Settings menu.

PPPoE and PPPoA Connection for WAN

Follow the instructions below to configure the Router to use a PPPoE or PPPoA for the Internet connection. Make sure you have all the necessary information before you configure the WAN connection.

1. Click to select the **PPPoE/PPPoA** radio button in the **WAN Settings** options list. This is selected by default if you are configuring the Router for the first time. If it is not selected, click the **PPPoE/PPPoA** radio button located under the **WAN Settings** heading.
2. The **ATM VC Settings** at the top of the menu should not be changed unless you have been instructed to change them. However, if you are instructed to change the **VPI** or **VCI** values, type in the values assigned for your account. Leave the **PVC** and **Virtual Circuit** settings at their default (*Pcv0* and *Enabled*) values for now. These can be used later if you are configuring multiple virtual circuits for your ADSL service.
3. Under the **PPPoE/PPPoA** heading, type the **User Name** and **Password** used for your ADSL account. A typical User Name will be in the form user@isp.com.au, the Password may be assigned to you by your ISP or you may have selected it when you set up the account with your ISP.
4. Choose the **Connection Type** from the pull-down menu located under the User Name and Password entry fields. This defines both the connection protocol and encapsulation method used for your ADSL service. The available options are *PPPoA VC-MUX*, *PPPoA LLC* and *PPPoE LLC*. If have not been provided specific information for the Connection Type setting, leave the default setting.
5. Leave the **MRU** value at the default setting (default = 1492) unless you have been instructed to change this.
6. If you are instructed to use enable **Default Route**, this setting specifies that the Router be used to define the default route to the Internet for your LAN. Whenever a computer on the LAN attempts to access the Internet, the Router becomes the Internet gateway to the computer.
7. Set **NAT** to *Enabled* unless you have been told to NAT must be *Disabled* for your account.
8. If you have not been instructed to change the ATM settings at the bottom of the menu, leave these at the default settings. If you have been given new settings to configure, select the **Service Category** and type in the values for **PCR** and **VCI** in Kbps.
9. When you are satisfied that all the WAN settings are configured correctly, click on the **Apply** button.
10. The new settings must be saved and the Router must be restarted for the settings to go into effect. To **Save & Reboot** the Router, click on the **Tools** directory tab and then click the **Save & Reboot** menu button. In the Save and Reboot menu, click the **Reboot** button under **Force the DSL-502T to system restart**. The Router will save the new settings and restart. Upon restarting the Router will automatically establish the WAN connection.

Bridged Connection for WAN

For Bridged connections it will be necessary for most users to install additional software on any computer that will be the Router for Internet access. The additional software is used for the purpose of identifying and verifying your account, and then granting Internet access to the computer requesting the connection. The connection software requires the user to enter the User Name and Password for the ISP account. This information is stored on the computer, not in the Router.

Follow the instructions below to configure a Bridged connection for the WAN interface.

WAN Settings Menu – Bridge Mode

1. Click to select the **Bridge Mode** radio button in the **WAN Settings** options list. The menu will change to offer a different set of configuration options.
2. Under the **ATM VC Setting** heading, do not change the **PVC** (*Pvc0*) index for the initial connection.
3. Also under the **ATM VC Setting**, you see two numbers, the **VCI** and **VPI** values. Do not change the **VPI** or **VCI** value unless you have been told to do so. These numbers are used to define a unique path for your connection. If you have been given specific settings for this to configure, type in the correct values assigned by your ISP.
4. Set the **Virtual Circuit** setting to *Enabled* in the pull-down menu if it is not already enabled.
5. Under **Bridge Mode**, choose the **Connection Type** from the pull-down menu. For bridge mode connections the available encapsulation methods are *1483 Bridged IP LLC* and *1483 Bridged IP VC-Mux*.
6. If you have not been instructed to change the ATM settings at the bottom of the menu, leave these at the default settings. If you have been given new settings to configure, select the **Service Category** and type in the values for **PCR** and **SCR** in Kbps.
7. When you are satisfied that all the WAN settings are configured correctly, click on the **Apply** button.
8. The new settings must be saved and the Router must be restarted for the settings to go into effect. To **Save & Reboot** the Router, click on the **Tools** directory tab and then click the **Save & Reboot** menu button. In the Save and Reboot menu, click the **Reboot** button under **Force the DSL-502T to system restart**. The Router will save the new settings and restart. Upon restarting the Router will automatically establish the WAN connection.

Static IP Address for WAN

When the Router is configured to use Static IP Address assignment for the WAN connection, you must manually assign a global IP Address, Subnet Mask and Gateway IP Address used for the WAN connection. Most users will also to configure DNS server IP settings in the DNS Settings configuration menu (see below). Follow the instruction below to configure the Router to use Static IP Address assignment for the WAN connection.

WAN Settings - Static IP

1. Click to select the **Static IP Address** radio button listed in the **WAN Settings** options list. The menu will change to offer a different set of configuration options.
2. Under the **ATM VC Setting** heading, do not change the **PVC** (*Pvc0*) index for the initial connection.
3. Also under the **ATM VC Setting**, you see two numbers, the **VCI** and **VPI** values. Do not change the **VPI** or **VCI** value unless you have been told to do so. These numbers are used to define a unique path for your connection. If you have been given specific settings for this to configure, type in the correct values assigned by your ISP.
4. Set the **Virtual Circuit** setting to *Enabled* in the pull-down menu if it is not already enabled.
5. Select the **Connection Type** from the pull-down menu under the **Static IP** heading. Your ISP should provide this information to you. The available options are *IPOA*, *1483 Bridged VC-Mux*, *1483 Bridged LLC*, and *1483 Routed VC-Mux*. If have not been provided specific information for the Connection Type setting, leave the default setting.
6. Change the **IP Address**, **Subnet Mask**, **Gateway Address** and (if available) **Secondary DNS** Server IP address as instructed by your ISP. Your ISP should have provided these IP settings to you.
7. Set **NAT** to *Enabled* unless you have been told to NAT must be *Disabled* for your account
8. When you are satisfied that all the WAN settings are configured correctly, click on the **Apply** button.
9. The new settings must be saved and the Router must be restarted for the settings to go into effect. To **Save & Reboot** the Router, click on the **Tools** directory tab and then click the **Save & Reboot** menu button. In the Save and Reboot menu, click the **Reboot** button under **Force the DSL-502T to system restart**. The Router will save the new settings and restart. Upon restarting the Router will automatically establish the WAN connection.

Multiple Private Virtual Connections

The Router supports multiple virtual connections. Up to eight PVCs to eight separate destinations can be created and operated simultaneously utilizing the same bandwidth. Additional PVC connections can be added for various purposes. For example, you may want to establish a private connection to remote office in order to create an extended LAN, or setup a server on a separate connection. Provisioning for additional PVC profiles must be done through your telecommunications services provider. Extended LAN operations employing multiple virtual connections require ADSL routers or modems at the remote site for a successful connection. Contact your ISP or telecommunications service provider if you are interested in setting up multiple virtual connections.

After the necessary arrangements have been made to use the Router with multiple virtual connections, follow the instructions below to setup the Router using the VPI/VCI settings given to you by your server provider.

Configure Multiple PVCs

Additional PVCs can be configured by first accessing the WAN configuration menu in the Home directory.

The screenshot shows the WAN Settings configuration page. The navigation bar includes 'Home', 'Advanced', 'Tools', 'Status', and 'Help'. The 'WAN Settings' section has three radio button options: 'Static IP Address', 'PPPoE/PPPoA', and 'Bridge Mode'. The 'Bridge Mode' section has a 'Connection Type' dropdown menu set to '1483 Bridged IP LLC'. The 'ATM VC Setting' section has a 'PVC' dropdown menu open, showing options from 'Pvc0' to 'Pvc7'. At the bottom right are 'Apply', 'Cancel', and 'Help' buttons.

Select new PVC to configure in the WAN menu

The PVC pull-down menu offers 8 virtual connections available for configuration. The default VC used by the Router is labeled Pvc0. Any additional connections that are configured must have a VPI/VCI combination that is unique to the Router. These numbers will have been already been established by your service provider on their network.

To add a new virtual connection:

1. Select the new **PVC** to configure from the pull-down menu.
2. Enter the values for the **VPI** and **VCI** given to you by your service provider.
3. To activate the VC, select *Enabled* from the **Virtual Circuit** pull-down menu.
4. Configure the WAN Settings and Connection Type as desired.

In the example below, a new VC (Pvc1) has been added using the WAN Settings menu. The connection is setup as a bridged connection.

Home **Advanced** **Tools** **Status** **Help**

WAN Settings

Please select the appropriate options to connect to your ISP.

Static IP Address **Choose this option to set static IP information provided to you by your ISP.**

PPPoE/PPPoA **Choose this option if your ISP uses PPPoE/PPPoA. (For most DSL users)**

Bridge Mode **Choose this option if your ISP uses Bridge Mode.**

Bridge Mode

Connection Type: 1483 Bridged IP LLC

ATM VC Setting

PVC: Pvc1

VPI: 2

VCI: 34

Virtual Circuit: Enabled

Apply **Cancel** **Help**

Configure new VC

The new VC appears can be configured separately in other menus such as Static Routing.

LAN IP Settings

You can configure the LAN IP address to suit your preference. Many users will find it convenient to use the default settings together with DHCP service to manage the IP settings for their private network. The IP address of the Router is the base address used for DHCP. In order to use the Router for DHCP on your LAN, the IP address pool used for DHCP must be compatible with the IP address of the Router. The IP addresses available in the DHCP IP address pool will change automatically if you change the IP address of the Router. See the next section for information on DHCP setup.

To access the **LAN Settings** menu, click the **LAN** button in the **Home** directory.

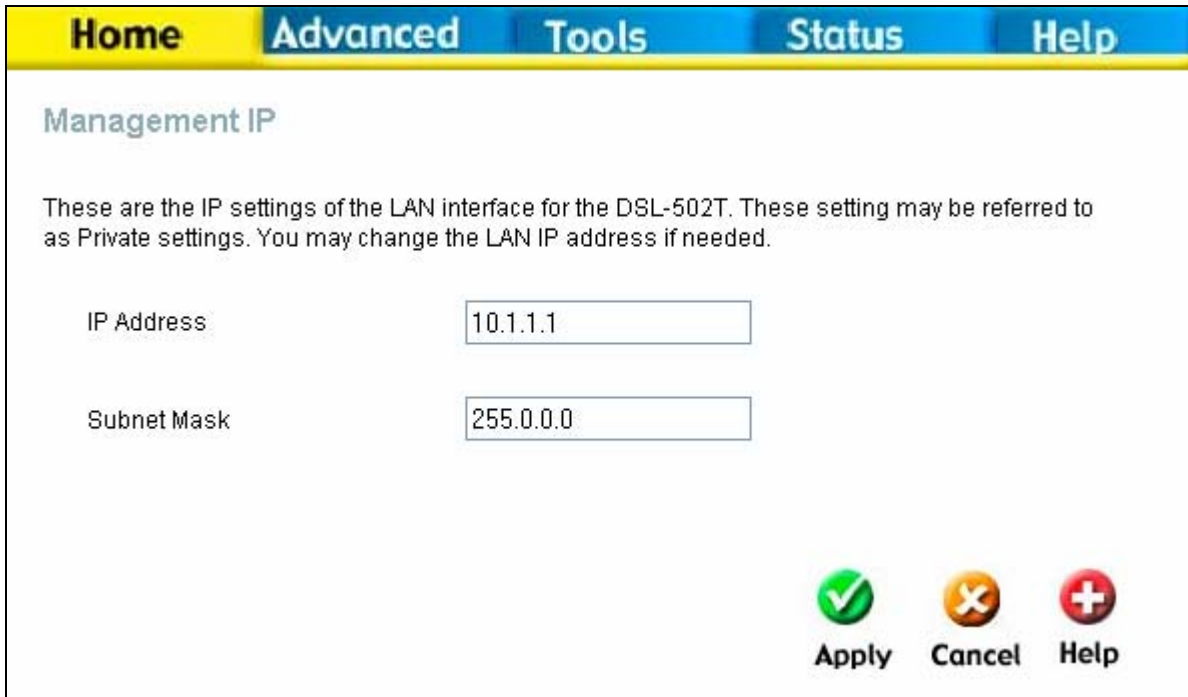



Home Advanced Tools Status Help

Management IP

These are the IP settings of the LAN interface for the DSL-502T. These setting may be referred to as Private settings. You may change the LAN IP address if needed.

IP Address

Subnet Mask

Apply Cancel Help

Configure LAN IP settings

To change the **LAN IP Address** or **LAN Network Mask**, type in the desired values and click the **Apply** button. Your web browser should automatically be redirected to the new IP address.

DHCP Server Settings for the LAN

The DHCP server is enabled by default for the Router's Ethernet LAN interface. DHCP service will supply IP settings to workstations configured to automatically obtain IP settings that are connected to the Router through the Ethernet port. When the Router is used for DHCP it becomes the default gateway for DHCP client connected to it. Keep in mind that if you change the IP address of the Router, you must change the range of IP addresses in the pool used for DHCP on the LAN.

To display the **DHCP Server** menu, click the **DHCP** button in the **Home** directory. Active DHCP Clients appear listed in the **DHCP Client List** below the configuration menu. Information about DHCP clients includes the IP address, MAC address, host name and lease time are displayed in the list.

Home **Advanced** **Tools** **Status** **Help**

DHCP Settings

The device can be setup as a DHCP Server to distribute IP addresses to the LAN network.

No DHCP Choose this option. The IP address must be manually assigned at each device connected to DSL-502T.

DHCP Server Choose this option to setup as a DHCP server to distribute IP addresses to the LAN network.

DHCP Relay Choose this option to setup as a DHCP Relay to relay DHCP request to the target DHCP server.

DHCP Server

Starting IP Address:

Ending IP Address:

Lease Time: Seconds

DHCP Clients List

Number	IP Address	MAC Address
1	10.1.1.2	08:00:46:2b:35:db

Configure DHCP server settings for the LAN

The three options for DHCP service are as follows:

- You may use the Router as a DHCP server for your LAN.
- You can disable DHCP service and manually configure IP settings for workstations.
- You use DHCP service provided by your ISP.

Follow the instructions below according to which of the above DHCP options you want to use. When you have configured the DHCP Settings as you want them, click the **Apply** button to commit the new settings. The new settings must be saved and the Router must be restarted for the settings to go into effect. To **Save & Reboot** the Router, click on the **Tools** directory tab and then click the **Save & Reboot** menu button. Click the **Reboot** button under **Force the DSL-502T to system restart**. The Router will save the new settings and restart. Upon restarting the Router will automatically establish the WAN connection.

Use the Router for DHCP

To use the built-in DHCP server, click to select the **DHCP Server** option if it is not already selected. The IP Address Pool settings can be adjusted. The **Starting IP Address** is the lowest available IP address (default = 10.1.1.2). If you change the IP address of the Router this will change automatically to be 1 more than the IP address of the Router. The **Ending IP Address** is the highest IP address number in the pool. Type in the **Lease Time** in the entry field provided. This is the amount of time in seconds that a workstation is allowed to reserve an IP address in the pool if the workstation is disconnected from the network or powered off.

Disable the DHCP Server

To disable DHCP, click to select the **No DHCP** option and click on the **Apply** button.

DHCP Relay

To use DHCP service from your ISP, select the **DHCP Relay** option and type the **DHCP Relay IP** address in the space provided. Click **Apply** to begin DHCP relay from the ISP.



Note

To use DHCP Relay from the ISP, DHCP Service Filtering must be disabled. See the **Firewall** section in the next chapter.

DNS Server Settings

The Router can be configured to relay DNS from your ISP or another available service to workstations on your LAN. When using DNS relay, the Router will accept DNS requests from hosts on the LAN and forward them to the ISP (or alternative) DNS servers. DNS relay can use auto discovery or the DNS IP address can be manually entered by the user. Alternatively, you may also disable the DNS relay and configure hosts on your LAN to use DNS servers directly. Most users who are using the Router for DHCP service on the LAN and are using DNS servers on the ISP's network, will leave DNS relay enabled (either auto discovery or user configured).

Configure DNS Settings

In the DNS Relay Selection pull-down menu, choose to *Use Auto Discovery*, *Use User Configured* or *Disable* DNS relay.

If you have not been given specific DNS server IP addresses or if the Router is not pre-configured with DNS server information, select the Auto Discover option for DNS relay. Auto discovery DNS instructs the Router to automatically obtain the DNS IP address from the ISP through DHCP. If your WAN connection uses a Static IP address, auto discovery for DNS cannot be used.

If you have DNS IP addresses provided by your ISP, enter these IP addresses in the available entry fields for the **Preferred DNS Server** and the **Alternative DNS Server**.

If you choose to disable DNS relay, it will be necessary to configure DNS settings for hosts on the LAN since they will not be depending on the Router to forward the DNS requests.

When you have configured the DNS settings as desired, click the **Apply** button.



Note

To use DNS Relay for computers on your local network, DNS Service Filtering must be disabled. See the **Firewall** section in the next chapter.

Save Settings and Reboot

When you have configured the DSL-502T with the settings you desire, make sure you save those settings. To save the system configuration settings, click the **Tools** tab. You will be presented first with the Administrator Settings menu. This menu is described in the next chapter. To save the current configuration, click the **Save & Reboot** button to view the menu pictured here.

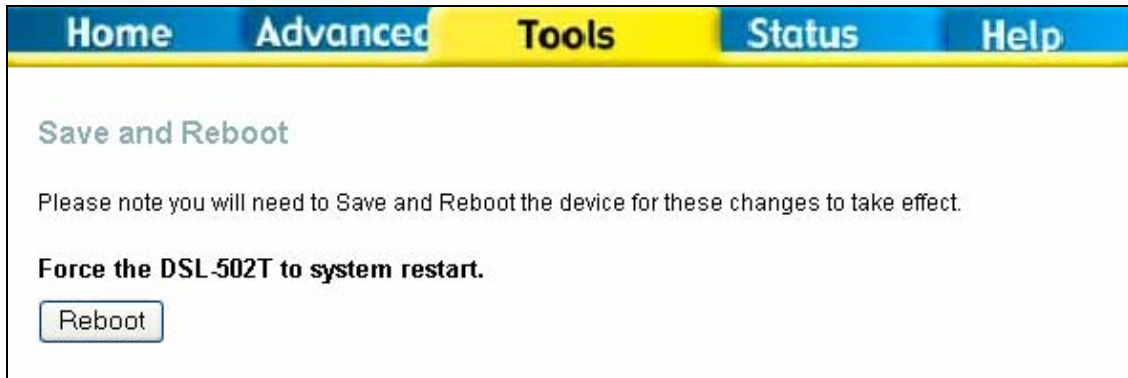

Save and Reboot menu

To save the settings you have configured, click the **Reboot** button under **Force the DSL-502T to system restart**.

Advanced Router Management

This chapter introduces and describes the management features that have not been presented in the previous chapter. These include the more advanced features used for network management and security as well as administrative tools to manage the Router, view statistics and other information used to examine performance and for troubleshooting.

Use your mouse to click the directory tabs and menu buttons in order to display the various configuration and read-only menus discussed below. The table below summarizes again the directories and menus available in the management web interface. In this chapter you will find descriptions for the menus located in the Advanced, Tools and Status directories.

Directory	Configuration and Read-only Menus
Home	Click the Home tab to access the Setup Wizard, WAN Configuration, LAN IP Configuration, DHCP for the LAN Setup and DNS Configuration menus.
Advanced	Click the Advanced tab to access the UPnP, Port Forwarding, DMZ, IP/MAC Filters, Firewall, NAT, ATM, Static Routing, Dynamic Routing (RIP) and Remote Access menus.
Tools	Click the Tools tab to access the Administrator Settings (used to set the system user name and password, backup and load settings), System Time Configuration, Firmware Upgrade, Diagnostic Test and Save & Reboot menus.
Status	Click the Status tab to view the Device Information, DHCP Clients, Event Log, Traffic Statistics and ADSL Status information windows.
Help	The Help menu presents links to pages that explain various functions and services provided by the Router.

UPnP

UPnP supports zero-configuration networking and automatic discovery for many types of networked devices. When enabled, it allows other devices that support UPnP to dynamically join a network, obtain an IP address, convey its capabilities, and learn about the presence and capabilities of other devices. DHCP and DNS service can also be used if available on the network. UPnP also allows supported devices to leave a network automatically without adverse effects to the device or other devices on the network.

UPnP can be supported by diverse networking media including Ethernet, Firewire, phone line and power line networking.

Select	Available Connections
<input checked="" type="radio"/>	connection0
<input type="radio"/>	connection1
<input type="radio"/>	connection2
<input type="radio"/>	connection3
<input type="radio"/>	connection4
<input type="radio"/>	connection5
<input type="radio"/>	connection6
<input type="radio"/>	connection7

Enable UPnP Menu

To enable UPnP for any available connection, click to check the **Enable UPnP** selection box, select the connection or connections on which you will enable UPnP listed under **Available Connections** and click the **Apply** button.

Port Forwarding

Use the Port Forwarding menu to create Virtual Server functions through the Router. A Virtual Server can allow remote users to access services on your LAN such as FTP for file transfers or SMTP and POP3 for e-mail. The DSL-502T will accept remote requests for these services at your Global IP Address, using the specified TCP or UDP protocol and port number, and then redirect these requests to the server on your LAN with the Private IP address you specify. Remember that the Private IP Address must be within the range specified for your LAN.

The Virtual Server feature employs UDP/TCP port redirection to direct traffic through the WAN port to specified servers on your private network. Port redirection can also be used to direct potentially hazardous packets to a proxy server outside your firewall. For example, you can configure the Router to direct HTTP packets to a designated HTTP server in the DMZ. You can define a set of instructions for a specific incoming port or for a range of incoming ports. Each instruction set or rule is indexed and can be modified or deleted later as needed.

Virtual server configuration sets can be used together with complimentary features such as Firewall Rules, DMZ devices and IP Filters to improve efficiency and security. Consider how these other functions will effect the virtual server sets you have configured and enabled.

The table below describes the configuration settings presented in the Virtual Server menu.

Virtual Server is used to allow Internet users access to LAN services.



Rule Name

Private IP

Protocol

Port Start Port End

Port Map

Apply **Cancel** **Help**

ID	Private IP	Protocol	Port Start	Port End	Port Map
----	------------	----------	------------	----------	----------

Virtual Server Menu and List

To modify virtual server settings for any previously created virtual server set listed, click on the note pad icon in the right hand column of the **Virtual Servers List** for the set you want to configure. The set will appear highlighted in the list and the parameters that have been configured appear in the settings fields above the list. Adjust the settings as desired and click the **Apply** button to put them into effect.

To configure a virtual server set, define the following settings in the Virtual Server configuration menu located in the top half of the browser window.

Parameter	Description
Rule Name	Provide a name for the rule. This name will not appear in the list below, however it may be useful if you later need to edit the settings for the rule. Rule names are optional.
Private IP	This is the IP address of the server on your LAN that will provide the service to remote users. The Private IP address is used to direct the service to a specific computer on your private network such as an FTP, Email or public web server. Type in the IP address of the server used for the service being configured here.
Protocol	You can select the transport protocol (TCP or UDP) that the application on the virtual server will use for its connections. Select one of the following options from the pull-down menu to define a <i>TCP</i> , <i>UDP</i> or <i>Both</i> . The choice of this protocol is dependent on the application that is providing the service. If you do not know which protocol to choose, check your application's documentation.
Port Start/Port End	Configure a range of ports for forwarding. Type the lowest numbered port in the range in the Port Start space. Type the highest numbered port in the Port End space. For a single port, just enter the same number in both spaces. Virtual server port redirection must be used with a specified server or computer on the LAN (identified by the Private IP address).
Port Map	This is the local port being forwarded to from the Port Start/Port End port(s). Keep in mind that if you use a non-standard port number for an application with a reserved UDP/TCP port, some additional configuration may be required for the servers or workstations using the application on the LAN side.

Click the **Apply** button to put the new virtual server configuration set or modification into effect. Any server sets configured in the menu will appear in the Virtual Server List with the new settings. The Router must save the new settings and reboot before the new virtual server configurations are applied.

To remove any configuration set from the Virtual Server List, click on the trashcan icon for set you want to delete.



Note

Some applications require multiple TCP or UDP ports to function properly. Applications such as Internet gaming, video conferencing, and Internet telephony are some examples of applications that often require multiple connections. These applications often conflict with NAT, and therefore require special handling. See the discussion of DMZ configuration below.

DMZ

Since some applications are not compatible with NAT, the Router supports use of a DMZ IP address for a single host on the LAN. This IP address is not protected by NAT and will therefore be visible to agents on the Internet with the right type of software. Keep in mind that any client PC in the DMZ will be exposed to various types of security risks. If you use the DMZ, take measures (such as client-based virus protection) to protect the remaining client PCs on your LAN from possible contamination through the DMZ.



The screenshot shows the DMZ configuration page in the router's web interface. At the top, there is a navigation bar with tabs for Home, Advanced (highlighted in yellow), Tools, Status, and Help. Below the navigation bar, the page title is "DMZ". A descriptive text states: "DMZ (Demilitarized Zone) is used to allow a single computer on the LAN to be exposed to the Internet." There are two radio buttons: "Enabled" (unselected) and "Disabled" (selected). Below the radio buttons is a text input field labeled "IP Address:" containing the value "0.0.0.0". At the bottom right of the page, there are three buttons: "Apply" (with a green checkmark icon), "Cancel" (with an orange 'x' icon), and "Help" (with a red plus icon).

DMZ IP address configuration

To designate a DMZ IP address, type in the **IP Address** of the server or device on your LAN, select the **Enabled** radio button and click the **Apply** button. To remove DMZ status from the designated IP address, select the Disabled radio button and click Apply. It will be necessary to save the settings and reboot the Router before the DMZ is activated.

Filters

Filter rules in the Router are put in place to allow or block specified traffic. The Filter Rules however can be used in a single direction to examine and then Allow or Deny traffic for Inbound (WAN to LAN) or Outbound (LAN to WAN) routed data. The rules based on IP address and TCP/UDP port.

Configure the filter rules as desired and click the **Apply** button to create the rule. The newly created rule appears listed in the Outbound Filter List at the bottom of the menu. The table below describes the various parameters that are configured for the filter rules.

ID	Source IP	Destination IP	Prot.	Act.	Enable
----	-----------	----------------	-------	------	--------

Filters Configuration Menu

To modify any previously created filter rule, click on the note pad icon in the right hand column of the Filter List for the set you want to configure. Adjust the settings as desired and click the **Apply** button to put the new settings into effect.

First determine the direction of the traffic you want the rule to filter. To filter WAN to LAN traffic, select the **Inbound Filter** option. Any new Inbound Filter rules created will appear in the list. Likewise, should you to filter LAN to WAN traffic, create an **Outbound Filter** rule.



Note

*The Service Filtering feature of the Firewall may interfere rules configured in the Filters menu. For example, FTP packets are not allowed through from the external network by default. See the **Firewall** section below for details.*

The parameters described below are used to set up filter rules.

Parameter	Description
Source IP	For an Outbound Filter, this is the IP address or IP addresses on your LAN for which you are creating the filter rule. For an Inbound Filter, this is the IP address or IP addresses for which you are creating the filter rule. You can opt to indicate a <i>Mask Range</i> , a <i>Single IP</i> , an <i>IP Range</i> or <i>Any IP</i> from the pull-down menu. Choosing Any IP will apply the rule to all WAN or all LAN IP addresses depending on which type of rule (Inbound or Outbound) is being configured.
Destination IP	Where the Destination IP address resides also depends on if you are configuring an Inbound or Outbound filter rule. You can opt to indicate a <i>Mask Range</i> , a <i>Single IP</i> , an <i>IP Range</i> or <i>Any IP</i> from the pull-down menu.
Source Port	The Source Port is the TCP/UDP port on either the LAN or WAN depending on if you are configuring an Outbound or Inbound Filter rule. Select one of the following options from the pull-down menu to define a <i>Any Port</i> , <i>Single Port</i> , <i>Port Range</i> or <i>Safe Range</i> (ports above 1024).
Destination Port	The Destination Port is the TCP/UDP port on either the LAN or WAN depending on if you are configuring an Outbound or Inbound Filter rule. Select one of the following options from the pull-down menu to define a <i>Any Port</i> , <i>Single Port</i> , <i>Port Range</i> or <i>Safe Range</i> (ports above 1024).
Protocol	Select the transport protocol (<i>TCP</i> , <i>UDP</i> or <i>All</i>) that will be used for the filter rule.
Action	Select to <i>Allow</i> or <i>Deny</i> transport of the data packets according to the criteria defined in the rule. Packets that are allowed are routed to their destination; packets that are denied are blocked.

Click the **Apply** button to put the new rule into effect. Any filter rule configured in the menu will appear in the Filters List with the new settings. The Router must save the new settings and reboot before the new rules are applied.

Firewall

The Firewall Configuration menu allows the Router to enforce specific predefined policies intended to protect against certain common types of attacks. There are two general types of protection (DoS, Port Scan) that can be enabled on the Router, as well as filtering for specific packet types sometimes used by hackers.

You can choose to **Enable** or **Disable** protection against a customized basket of attack and scan types. To enable **DoS Protection** or **Port Scan Protection**, select the **Enable** radio button for the protection type and click in the selection boxes for the various types of protection listed under each.



Note

Service Filtering may interfere with other configurations such as DHCP Relay or Remote Management via Telnet.

Home **Advanced** **Tools** **Status** **Help**

Firewall Configuration

DoS Protection
DoS attacks can be checked based on your specific need.

State: Enabled Disabled

SYN Flooding checking
 ICMP Redirection checking

Port Scan Protection
Port Scan attacks can be checked based on your specific need.

State: Enabled Disabled

NMAP FIN/URG/PSH attack
 Xmas Tree attack
 Null Scan attack
 SYN/RST attack
 SYN/FIN attack

Service Filtering
The following services can be blocked based on your specific need.

Ping from External Network
 Telnet from External Network
 FTP from External Network
 DNS from External Network
 IKE from External Network
 RIP from External Network
 DHCP from External Network

Apply Cancel Help

Firewall Configuration Menu

When DoS, Port Scan, or Service Filtering Protection is enabled, it will create a firewall policy to protect your network against the following:

DoS Protection	Port Scan Protection	Service Filtering
SYN Flood check	Nmap/FIN attack	Ping from WAN
ICMP Redirection check	URG/PSH attack	Telnet from WAN
	Xmas Tree Scan	FTP from WAN
	Null Scan attack	DNS from WAN
	SYN/RST attack	IKE from WAN
	SYN/FIN Scan	RIP from WAN
		DHCP from WAN

A DoS "denial-of-service" attack is characterized by an explicit attempt by attackers to prevent legitimate users of a service from using that service. Examples include: attempts to "flood" a network, thereby preventing legitimate network traffic, attempts to disrupt connections between two machines, thereby preventing access to a service, attempts to prevent a particular individual from accessing a service, or, attempts to disrupt service to a specific system or person.

Port scan protection is designed to block attempts to discover vulnerable ports or services that might be exploited in an attack from the WAN.

The Service Filtering options allow you to block FTP, Telnet response, Pings, etc, from the external network. Check the category you want to block to enable filtering of that type of packet.

When you have selected the desired Firewall policies, click the **Apply** button to enforce the policies. Remember to save any configuration changes.

NAT

Network Address Translation (NAT) may be disabled on the Router. This should only be disabled if there are specific reasons to do so. When NAT is disabled on the Router it is not possible to allow more than one computer or server (any single IP address on the LAN) to access the Internet unless some form of NAT is provided by another system.

NAT can be enabled or disabled system-wide. If you are using multiple connections (Multiple PVCs) the status of NAT will be the same for all IP routed connections.



NAT Enable/Disable Menu

To disable or enable NAT, select the desired option *Enabled* or *Disabled* from the pull-down menu and click the **Apply** button.

ATM

The ATM Virtual Circuit connection menu is used to configure the WAN connection. If you are using multiple PVCs, you can change the configuration of any PVC in this menu. To create new or additional PVCs, read the section below on Multiple PVCs.

This menu can be used as an alternative menu to configure the same settings found on the WAN menu in the Home directory.

The screenshot shows the 'ATM' configuration menu. At the top, there are navigation tabs: 'Home', 'Advanced' (highlighted in yellow), 'Tools', 'Status', and 'Help'. Below the tabs, the 'ATM' section contains the following settings:

- PVC: Pvc0 (dropdown menu)
- Service Category: UBR (dropdown menu)
- PCR: [] kbps
- SCR: [] kbps

Below the ATM settings is a 'Connections' section with the following option:

- IGMP Proxy: Disabled Enabled

At the bottom right of the menu are three buttons: 'Apply' (green checkmark icon), 'Cancel' (orange 'X' icon), and 'Help' (red plus icon).

ATM Virtual Circuit configuration menu

To configure an existing PVC configuration set, click the corresponding notepad icon in the right-hand column of the ATM VCs List. The PVCs current settings appear above in the entry fields of the ATM VC Settings menu. Configure the appropriate settings and click the **Apply** button to put the new settings into effect.

Static Routing

Use Static Routing to specify a route used for data traffic within your Ethernet LAN or to route data on the WAN. This is used to specify that all packets destined for a particular network or subnet use a predetermined gateway.

Home **Advanced** **Tools** **Status** **Help**

Routing Table

IP Routes are used to define gateways and hops used to route data traffic. Most users will not need to use this feature as the previous gateway and LAN IP settings on your host computers should be sufficient.

Destination

Netmask

Gateway

Connection

Apply Cancel Help

ID	Destination	Netmask	Gateway	Interface
----	-------------	---------	---------	-----------

Static Routing menu

To add a static route to a specific destination IP on the local network, enter a **Destination** IP address, **Netmask**, then click the **Gateway** radio button and type in the Gateway's IP address. Click **Apply** to enter the new static route in the table below. The route becomes active immediately upon creation.

To add a static route to a specific destination IP on the WAN, click the Connection radio button and choose a connection from the pull-down menu, then enter a **Destination** IP address and **Netmask**. Click **Apply** to enter the new static route in the table below. The route becomes active immediately upon creation.

To remove a static route from the table in the bottom half of the window, choose to **Delete** it from the table and click the **Apply** button. Remember to save the configuration changes.

Dynamic Routing (RIP)

The Router supports RIP v1 and RIP v2 used to share routing tables with other Layer 3 routing devices on your local network or remote LAN.

The screenshot shows the 'RIP System Wide Configuration' page. At the top, there is a navigation bar with tabs for 'Home', 'Advanced' (which is highlighted in yellow), 'Tools', 'Status', and 'Help'. Below the navigation bar, the title 'RIP System Wide Configuration' is displayed. A descriptive paragraph explains that RIP is an Internet protocol used to share routing table information. The configuration area includes three dropdown menus: 'RIP' is set to 'Disabled', 'Protocol' is set to 'RIPv1', and 'Direction' is set to 'Both'. At the bottom right of the configuration area, there are three buttons: 'Apply' (with a green checkmark icon), 'Cancel' (with an orange 'X' icon), and 'Help' (with a red plus icon).

Dynamic Routing (RIP) menu

To enable RIP, select *Enabled* from the **RIP** pull-down menu, select the **Protocol** (*RIPv1*, *RIPv2* and *RIPv1 Compatible*) and **Direction** (*In*, *Out*, or *Both*), and click **Apply**.

The RIPv1 Compatible option will respond to or send RIP requests compatible with both RIP v1 and RIP v2.

The direction configuration refers to the RIP request. Select *In* to allow RIP requests from other devices. Select *Out* to instruct the Router to make RIP requests for routing tables from other devices. Select *Both* to share routing tables in both directions.



Remote Access

Use the Remote Access menu in the Advanced directory to enable remote management of the Router through the web interface or via Telnet from a specified source IP address. This will enable Router and network management from outside the local network through the WAN connection. Remote management is disabled by default.



Note

Check the Service Filtering settings in the **Firewall** menu if you will use Telnet to manage the Router from a remote station. Telnet packets from the External Network are filtered by default.

Home	Advanced	Tools	Status	Help
Remote Web Management				
State	<input type="radio"/> Enabled <input checked="" type="radio"/> Disabled			
IP Address	<input type="text" value="0.0.0.0"/>			
Netmask	<input type="text" value="255.255.255.255"/>			
Remote Telnet Management				
State	<input type="radio"/> Enabled <input checked="" type="radio"/> Disabled			
IP Address	<input type="text" value="0.0.0.0"/>			
Netmask	<input type="text" value="255.255.255.255"/>			
   Apply Cancel Help				

Remote Management Menus

To use Remote Management, select the Enabled radio button for the type of management desired (Telnet or web), type in the remote IP address allowed Telnet or web management access and the Netmask and click the **Apply** button. Be sure to change the administrator's password before you enable remote management.

Tools and Utilities

Click the **Tools** tab to reveal the menu buttons for various functions located in this directory. The **Administrator Settings** is the first menu that appears in the Tools directory. It is used to change the system password used to access the web manager, to save or load Router configuration settings and to restore default settings. The functions in this and the other Tools menus are described below.

The screenshot shows the web interface with the 'Tools' tab selected. The 'Administrator Settings' section is active. It contains the following elements:

- Navigation tabs: Home, Advanced, **Tools**, Status, Help.
- Section title: Administrator Settings.
- Text: There is only one account that can access the DSL-502T's Web-Management interface.
- Administrator (The Login Name is "admin")
- Form fields: New Password and Confirm Password.
- Buttons: Apply (green checkmark), Cancel (orange X), Help (red plus).
- Section: Save Settings To Local Hard Drive with a Save button.
- Section: Load Settings From Local Hard Drive with a text input field, a Browse... button, and a Load button.
- Note: The system has to be restarted after the configuration is restored.
- Section: Restore To Factory Default Settings with a Restore button.

System Tools Administrative functions

Change System Password

To change the password used to access the Router web manager, click the **Admin** button in the **Tools** directory to display the Administrator Settings menu. Under the Administrator heading, type the **New Password** and **Confirm Password** to be certain you have typed it correctly. Click the **Apply** button to activate the new password. The System User Name remains "admin", this cannot be changed using the web manager interface. Be sure to save the new setting (see below).

This screenshot is identical to the previous one, showing the 'Administrator Settings' menu. The 'New Password' and 'Confirm Password' input fields are highlighted with a grey background to indicate the focus for changing the system password.

Administrator Settings change password menu

Save or Load Configuration File

Once you have configured the Router to your satisfaction, it is a good idea to back up the configuration file to your computer. To save the current configuration settings to your computer, click the **Admin** button in the **Tools** directory to display the Administrator Settings menu. Click the **Save** button to **Save Settings to Local Hard Drive**. You will be prompted to select a location on your computer to put the file. The file type is .xml (HTML) and may be named anything you wish.

To load a previously saved configuration file, click the **Browse** button and locate the file on your computer. Click the **Load** button to **Load Settings From Local Hard Drive**. Confirm that you want to load the file when prompted and the process is completed automatically. The Router will reboot and begin operating with the configuration settings that have just been loaded.

The screenshot shows a web interface with three main sections:

- Save Settings To Local Hard Drive**: Contains a single button labeled "Save".
- Load Settings From Local Hard Drive**: Contains a text input field, a "Browse..." button, and a "Load" button.
- Restore To Factory Default Settings**: Contains a single button labeled "Restore".

Below the "Load Settings From Local Hard Drive" section, there is a note: "Note: The system has to be restarted after the configuration is restored."

Save System Settings and Restore Defaults

Restore Factory Default Settings

To reset the Router to its factory default settings, click the **Restore** button in the Administrator Settings menu. You will be prompted to confirm your decision to reset the Router. The Router will reboot with the factory default settings including IP settings.

Time

The Router provides a number of options to maintain current date and time including SNTP.

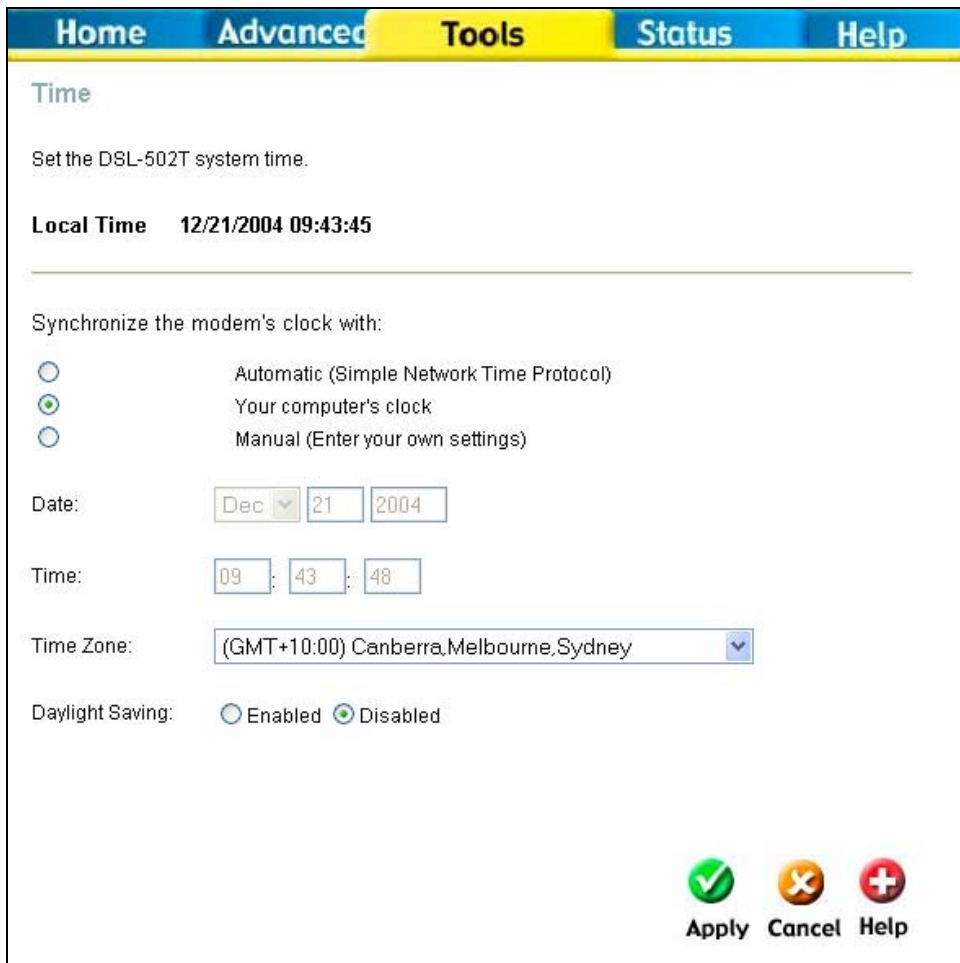

Home **Advanced** **Tools** **Status** **Help**

Time

Set the DSL-502T system time.

Local Time 12/21/2004 09:43:45

Synchronize the modem's clock with:

Automatic (Simple Network Time Protocol)

Your computer's clock



Manual (Enter your own settings)

Date: Dec 21 2004

Time: 09 : 43 : 48

Time Zone: (GMT+10:00) Canberra, Melbourne, Sydney

Daylight Saving: Enabled Disabled

Apply **Cancel** **Help**

Time Configuration

To configure system time on the Router, select the method used to maintain time. The options available include SNTP, using your computer's system clock (default) or set the time and date manually. If you opt to use SNTP, you must enter the SNTP server URL or IP address. Click the **Apply** button to set the system time.

Firmware Upgrade



Performing a Firmware Upgrade can sometimes change the configuration settings. Be sure to back-up the Router's configuration settings before upgrading the firmware.

Use the Firmware Upgrade menu to load the latest firmware for the device. Note that the device configuration settings may return to the factory default settings, so make sure you save the configuration settings with the System Settings menu described above.

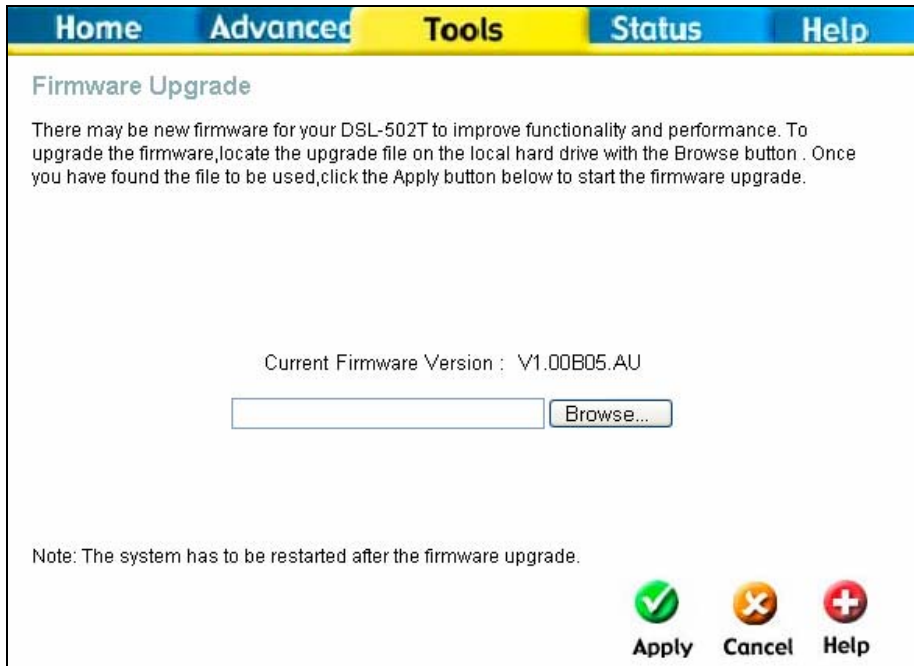

Firmware Upgrade

To upgrade firmware, type in the name and path of the file or click on the **Browse** button to search for the file. Click the **Apply** button to begin copying the file. The file will load and restart the Router automatically.

Test

The Test menus are used to test connectivity of the Router. A Ping test may be done through the local or external interface to test connectivity to known IP addresses. The diagnostics feature executes a series of test of your system software and hardware connections. Use this Test menu when working with your ISP to troubleshoot problems.

Ping Test

Ping IP Address

Ping Result :

```

PING 10.1.1.2 (10.1.1.2): 64 data bytes
72 bytes from 10.1.1.2: icmp_seq=0 ttl=128 time=0.0 ms
72 bytes from 10.1.1.2: icmp_seq=1 ttl=128 time=0.0 ms
72 bytes from 10.1.1.2: icmp_seq=2 ttl=128 time=0.0 ms
--- 10.1.1.2 ping statistics ---
3 packets transmitted, 3 packets received, 0% packet loss
round-trip min/avg/max = 0.0/0.0/0.0 ms
    
```

Diagnostic Test

The diagnostics feature executes a series of test of your system software and hardware connections. Use the feature when working with your ISP to troubleshoot problems.

Virtual Circuits :

This Page is used for performing diagnostics on the system.

Testing Connectivity to modem	
Testing Ethernet LAN connection	PASS
Testing ADSL Connection	
Testing ADSL Synchronization	FAIL
Testing Circuit for Network Connection	
Testing ATM OAM segment ping	SKIPPED
Testing ATM OAM end to end ping	SKIPPED
Testing PPPoE Connectivity	Disconnected
Validating assigned IP address	N/A
Testing Internet Connectivity	
Ping Primary Domain Names Server	SKIPPED
Ping www.dlink.com.au	SKIPPED

 Help

Ping and Diagnostics Test Menu

Ping Test

Type the IP address you want to Ping and click on the **Ping** button. The results will appear below.

Diagnostic Test

Select the Virtual Circuit and click the Submit button. A message will appear informing you if the loop test succeeded or failed.

The diagnostics utility will run a series of test to check whether the device's connections are up and working. This takes only a few seconds. The program reports whether the test passed or failed. A test may be skipped if the program determines that no suitable interface is configured on which to run the test.

Save Settings and Reboot

When you have configured the DSL-502T with the settings you desire, make sure you save those settings. To save the system configuration settings, click the **Tools** tab. You will be presented first with the Administrator Settings menu. This menu is described in the next chapter. To save the current configuration, click the **Save & Reboot** button to view the menu pictured here.



Save and Reboot menu

To save the settings you have configured, click the **Reboot** button under **Force the DSL-502T to system restart**.

Router Status Information

Use the various read-only menus to view system information and monitor performance.

Device Information Display

Use the Device Information window to quickly view basic current information about the LAN and WAN interfaces.

Home		Advanced		Tools		Status		Help	
Device Information									
Firmware Version : V1.00B05.AU									
LAN									
MAC Address	00:0d:88:cb:a8:c2								
IP Address	10.1.1.1								
Subnet Mask	255.0.0.0								
DHCP Server	Enabled								
NAT	Enabled								
WAN									
Virtual Circuit	<input type="text" value="Pvc0"/>								
Status	Disconnected								
Connection Type	pppoe								
IP Address	N/A								
Subnet Mask	N/A								
Default Gateway	N/A								
DNS Server	N/A								
									
									Help

Device Information display

DHCP Clients

View all current DHCP clients connected to the DSL-502T.

Home Advanced Tools Status Help				
DHCP Clients				
MAC Address	IP Address	Host Name		
08:00:46:2b:35:db	10.1.1.2	scott		

DHCP Clients list

Log

The system log displays chronological event log data. Use the navigation buttons to view or scroll log pages. You may also save a simple text file containing the log to your computer. Click the Save Log button and follow the prompts to save the file.

Home Advanced Tools Status Help				
View Log				
View Log displays the activities occurring on the DSL-502T.				
First Page	Last Page	Previous	Next	Clear Save
 Help				
page 1 of 16				
Time	Message			
Aug 10 05:23:33>	Couldn't get channel number: Transport endpoint is not connected			
Aug 10 05:23:33>	Doing disconnect			
Aug 10 05:23:34>	pppd 2.4.1 started by root, uid 0			
Aug 10 05:25:14>	System Call Error			
Aug 10 05:25:14>	Connecting PPPoE socket: 00:00:00:00:00:00 0000 0x1000d3b8			
Aug 10 05:25:14>	Couldn't get channel number: Transport endpoint is not connected			
Aug 10 05:25:14>	Doing disconnect			
Aug 10 05:25:15>	pppd 2.4.1 started by root, uid 0			

Log display

Click **Clear** to delete the current log information.

Traffic

See the Traffic Statistics window to monitor traffic on the Ethernet, USB or ADSL Internet connection. Select the interface for which you want to view packet statistics and the information will appear below. Click **Refresh** to view traffic information.

Traffic Statistics display Receive and Transmit packets passing through the DSL-502T.

Choose an interface to view your network status:

Ethernet Display Receive and Transmit packages through Ethernet

ADSL Display Receive and Transmit packages through ADSL

USB Display Receive and Transmit packages through USB

Refresh  Help

Transmit	
Good Tx Frames	4242
Good Tx Broadcast Frames	4
Good Tx Multicast Frames	0
Tx Total Bytes	882852
Collisions	0
Error Frames	0
Carrier Sense Errors	0

Receive	
Good Rx Frames	4632
Good Rx Broadcast Frames	411
Good Tx Multicast Frames	36
Rx Total Bytes	652002
CRC Errors	3
Undersized Frames	0
Overruns	0

Traffic Statistics information

ADSL

Use the ADSL Status information and the Test page for troubleshooting the ADSL connection.

ADSL Status

ADSL status shows the ADSL physical layer status.

ADSL Firmware Version: 4.01.00.00 - 1.01.00.00 - 1.01.00.00 Annex A - 01.06.06 - 0.49

Line State: Disconnected

Modulation: Multi-mode

Annex Mode: ANNEX_A

Max Tx Power: -38 dBm/Hz

Item	Downstream	Upstream	Unit
SNR Margin	0	0	dB
Line Attenuation	0	0	dB
Data Rate	0	0	kbps

 Help

ADSL Status information



Technical Specifications

General		
Standards:	ITU G.992.1 (G.dmt) ITU G.992.2 (G.lite) ITU G.994.1 (G.Hs) ITU-T Rec. I.361 ITU-T Rec. I.610 IEEE 802.3 IEEE 802.3u IEEE 802.1d RFC 791 (IP Routing) RFC 792 (UDP) RFC 826 (ARP) RFC 1058 (RIP 1) RFC 1389 (RIP 2) RFC 1213 compliant RFC 1483 (Bridged Ethernet) RFC 1577 (IP over ATM)	RFC 1661 (PPP) RFC 1994 (CHAP) RFC 1334 (PAP) RFC 2364 (PPP over ATM) RFC 1631 (NAT) RFC 1877 (Automatic IP assignment) RFC 2516 (PPP over Ethernet) Supports RFC 2131 and RFC 2132 (DHCP) Compatible with all T1.413 issue 2 (full rate DMT over analog POTS), and CO DSLAM equipment Supports ATM Forum UNI V3.1 PVC
Protocols:	TCP/IP UDP RIP-1 RIP-2 IGMP	DHCP BOOTP ARP AAL5
Data Transfer Rate:	G.dmt full rate: Downstream up to 8 Mbps Upstream up to 640 Kbps G.lite: Downstream up to 1.5 Mbps Upstream up to 512 Kbps	
Media Interface:	RJ-11 port ADSL telephone line connection RJ-45 port for 10/100BASET Ethernet connection USB port	

Physical and Environmental	
DC Inputs:	Input: 100V ~ 240V AC 50 ~ 60Hz
Power Adapter:	Output: 9V AC, 1A
Power Consumption:	3 Watts (max)
Operating Temperature:	5° to 40° C (41° - 104° F)
Humidity:	5 to 95% (non-condensing)
Dimensions:	142 (W) x 117(D) x 31(H) mm
Weight:	202 g
EMI :	FCC Class B, CE Class B
Safety:	CSA International
Reliability:	Mean Time Between Failure (MTBF) min. 4 years



IP Address Setup

The DSL-502T is designed to provide network administrators maximum flexibility for IP addressing on the Ethernet LAN. The easiest IP setup choice in most cases is to let the Router do it using DHCP, which is enabled by default. This appendix briefly describes various options including DHCP, used for IP setup on a LAN. If you are new to IP networking, the next appendix provides some background information on basic IP concepts.

Assigning Network IP Addresses

The IP address settings, which include the IP address, subnet mask and gateway IP address are the first and most important internal network settings that need to be configured. The Router is assigned a default LAN IP address and subnet mask. If you do not have a preexisting IP network and are setting one up now, using the factory default IP address settings can greatly ease the setup process. If you already have a preexisting IP network, you can adjust the IP settings for the Router to fit within your existing scheme.

Using the Default IP Address

The Router is shipped with a preset default IP address setting of 10.1.1.1 for the LAN port. There are two ways to use this default IP address, you can manually assign an IP address and subnet mask for each PC on the LAN or you can instruct the Router to automatically assign them using DHCP. The simplest method is to use DHCP. The DHCP function is active by default.

Manual IP Address Assignment

Manually configuring IP settings for the LAN means you must manually set an IP address, subnet mask and IP address of the default gateway (the Router's IP address) on each networked computer. The example listed below describes IP configuration for computers running Windows 95 or Windows 98. Regardless of what operating system is used on each workstation, the three network IP settings must be defined so the network interface used by each workstation can be identified by the Router, and vice versa. For detailed information about configuring your workstations IP settings, consult the user's guide included with the operating system or the network interface card (NIC).

1. In Windows 95/98, click on the **Start** button, go to **Settings** and choose **Control Panel**.
2. In the window that opens, double-click on the **Network** icon.
3. Under the Configuration tab, select the **TCP/IP** component and click *Properties*.
4. Choose the *Specify an IP address* option and edit the address settings accordingly. Consult the table below for IP settings on a Class C network.

Using Default IP without DHCP			
Host	IP Address	Subnet Mask	Gateway IP
Router	10.1.1.1	255.0.0.0	
Computer #1	10.1.1.2	255.0.0.0	10.1.1.1
Computer #2	10.1.1.3	255.0.0.0	10.1.1.1
Computer #3	10.1.1.4	255.0.0.0	10.1.1.1

IP Setup - Example #1

Please note that when using the default IP address as in the above example, the first number in the IP address must always be the same with only the second, third and fourth number changing. The first number defines the network IP address (all machines must belong to the same IP

network), while the last three numbers denote the host IP address (each computer must have a unique address to distinguish it on the network). The IP address scheme used in Example #1 can be used for any LAN that requires up to 253 separate IP addresses (excluding the Router). Notice that the subnet mask is the same for all machines and the default gateway address is the LAN IP address of the Router.

It is a good idea to make a note of each device's IP address for reference during troubleshooting or when adding new stations or devices.

Using DHCP

The second way to use the default settings is to allow the Router to automatically assign IP settings for workstation using DHCP. To do this, simply make sure your computers' IP addresses are set to 0.0.0.0 (under Windows, choose the option Obtain an IP address automatically in the TCP/IP network component described above). When the computers are restarted, their IP settings will automatically be assigned by the Router. The Router is set by default to use DHCP. See the discussion in Chapter 3 for information on how to use configure the Router for DHCP.

Changing the IP Address of the Router

When planning your LAN IP address setup, you may use any scheme allowed by rules that govern IP assignment. It may be more convenient or easier to remember an IP scheme that use a different address for the Router. Or you may be installing the Router on a network that has already established the IP settings. Changing the IP address is a simple matter and can be done using the web manager (see *LAN IP Address* in Chapter 5). If you are incorporating the Router into a LAN with an existing IP structure, be sure to disable the DHCP function. Also, consider the effects of NAT (Network Address Translation). This is enabled by default but may be disabled in the NAT menu of the Advanced directory.

An IP addressing scheme commonly used for Ethernet LANs establishes 10.0.0.1 as the base address for the network. Using Example #2 below, the Router is assigned the base address 10.0.0.1 and the remaining addresses are assigned manually or using DHCP.

Alternative IP Assignment			
Host	IP Address	Subnet Mask	Gateway IP
Router	10.0.0.1	255.0.0.0	
Computer #1	10.0.0.2	255.0.0.0	10.0.0.1
Computer #2	10.0.0.3	255.0.0.0	10.0.0.1
Computer #3	10.0.0.4	255.0.0.0	10.0.0.1

IP Setup - Example #2

These two examples are only examples you can use to help you get started. Other common private network IP addressing schemes use a base address of 192.168.0.1 or 192.168.1.1. If you are interested in more advanced information on how to use IP addressing on a LAN there are numerous resources freely available on the Internet. There are also many books and chapters of books on the subject of IP address assignment, IP networking and the TCP/IP protocol suite.

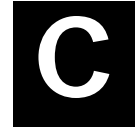

IP Concepts

This appendix describes some basic IP concepts, the TCP/IP addressing scheme and shows how to assign IP Addresses.

When setting up the Router, you must make sure it has a valid IP address. Even if you will not use the WAN port (ADSL port), you should, at the very least, make sure the Ethernet LAN port is assigned a valid IP address. This is required for telnet, in-band SNMP management, and related functions such as "trap" handling and TFTP firmware download.

IP Addresses

The Internet Protocol (IP) was designed for routing data between network sites all over the world, and was later adapted for routing data between networks within any site (often referred to as "subnetworks" or "subnets"). IP includes a system by which a unique number can be assigned to each of the millions of networks and each of the computers on those networks. Such a number is called an IP address.

To make IP addresses easy to understand, the originators of IP adopted a system of representation called "dotted decimal" or "dotted quad" notation. Below are examples of IP addresses written in this format:

201.202.203.204 189.21.241.56 125.87.0.1

Each of the four values in an IP address is the ordinary decimal (base 10) representation of a value that a computer can handle using eight "bits" (binary digits — 1s and 0s). The dots are simply convenient visual separators.

Zeros are often used as placeholders in dotted decimal notation; 189.21.241.56 can therefore also appear as 189.021.241.056.

IP networks are divided into three classes on the basis of size. A full IP address contains a network portion and a "host" (device) portion. The network and host portions of the address are different lengths for different classes of networks, as shown in the table below.

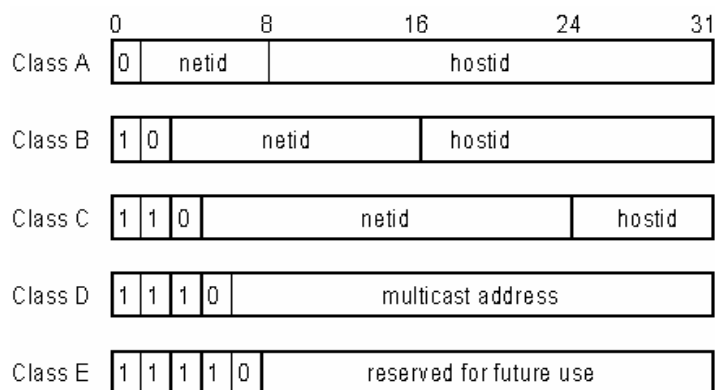

Networks attached to the Internet are assigned class types that determine the maximum number of possible hosts per network. The previous figure illustrates how the net and host portions of the IP address differ among the three classes. Class A is assigned to networks that have more than 65,535 hosts; Class B is for networks that have 256 to 65534 hosts; Class C is for networks with less than 256 hosts.

IP Network Classes			
Class	Maximum Number of Networks in Class	Network Addresses (Host Portion in Parenthesis)	Maximum Number of Hosts per Network
A	126	1(.0.0.0) to 126(.0.0.0)	16,777,214
B	16,382	128.1(.0.0) to 191.254(.0.0)	65,534
C	2,097,150	192.0.1(.0) to 223.255.254(.0)	254

Note: All network addresses outside of these ranges (Class D and E) are either reserved or set aside for experimental networks or multicasting.

When an IP address's host portion contains only zero(s), the address identifies a network and not a host. No physical device may be given such an address.

The network portion must start with a value from 1 to 126 or from 128 to 223. Any other value(s) in the network portion may be from 0 to 255, except that in class B the network addresses 128.0.0.0 and 191.255.0.0 are reserved, and in class C the network addresses 192.0.0.0 and 223.255.255.0 are reserved.

The value(s) in the host portion of a physical device's IP address can be in the range of 0 through 255 as long as this portion is not all-0 or all-255. Values outside the range of 0 to 255 can never appear in an IP address (0 to 255 is the full range of integer values that can be expressed with eight bits).

The network portion must be the same for all the IP devices on a discrete physical network (a single Ethernet LAN, for example, or a WAN link). The host portion must be different for each IP device — or, to be more precise, each IP-capable port or interface — connected directly to that network.

The network portion of an IP address will be referred to in this manual as a **network number**; the host portion will be referred to as a **host number**.

To connect to the Internet or to any private IP network that uses an Internet-assigned network number, you must obtain a registered IP network number from an Internet-authorized network information center. In many countries you must apply through a government agency, however they can usually be obtained from your Internet Service Provider (ISP).

If your organization's networks are, and will always remain, a closed system with no connection to the Internet or to any other IP network, you can choose your own network numbers as long as they conform to the above rules.

If your networks are isolated from the Internet, e.g. only between your two branch offices, you can assign any IP Addresses to hosts without problems. However, the Internet Assigned Numbers Authority (IANA) has reserved the following three blocks of IP Addresses specifically for private (stub) networks:

Class	Beginning Address	Ending Address
A	10.0.0.0	10.255.255.255
B	172.16.0.0	172.31.255.255
C	192.168.0.0	192.168.255.255

It is recommended that you choose private network IP Addresses from the above list. For more information on address assignment, refer to RFC 1597, *Address Allocation for Private Internets* and RFC 1466, *Guidelines for Management of IP Address Space*.

Subnet Mask

In the absence of subnetworks, standard TCP/IP addressing may be used by specifying subnet masks as shown below.

IP Class	Subnet Mask
Class A	255.0.0.0
Class B	255.255.0.0
Class C	255.255.255.0

Subnet mask settings other than those listed above add significance to the interpretation of bits in the IP address. The bits of the subnet mask correspond directly to the bits of the IP address. Any bit in a subnet mask that is to correspond to a net ID bit in the IP address must be set to 1.

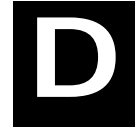

Microfilters and Splitters

Most ADSL clients will be required to install a simple device that prevents the ADSL line from interfering with regular telephone services. These devices are commonly referred to as microfilters or sometimes called (inaccurately) line splitters. They are easy to install and use standard telephone connectors and cable.

Some ADSL service providers will send a telecommunications technician to modify the telephone line, usually at the point where the telephone line enters the building. If a technician has divided or split your telephone line into two separate lines - one for regular telephone service and the other for ADSL - then you do not need to use any type of filter device. Follow the instructions given to you by your ADSL service provider about where and how you should connect the Router to the ADSL line.

Microfilters

Unless you are instructed to use a "line splitter" (see below), it will be necessary to install a microfilter (low pass filter) device for each telephone or telephone device (answering machines, Faxes etc.) that shares the line with the ADSL service. Microfilters are easy-to-install, in-line devices, which attach to the telephone cable between the telephone and wall jack. Microfilters that install behind the wall plate are also available. A typical in-line microfilter installation is shown in the diagram below.

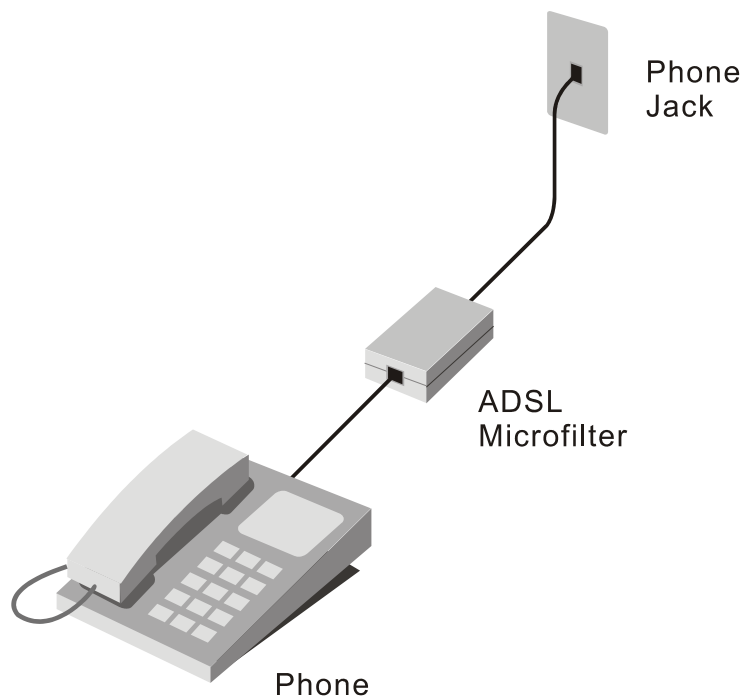

Microfilter Installation



Note

Do not install the microfilter between the Router and the telephone jack. Microfilters are only intended for use with regular telephones, Fax machines and other regular telephone devices.

Line Splitter

If you are instructed to use a "line splitter", you must install the device between the Router and the phone jack. Use standard telephone cable with standard RJ-11 connectors. The splitter has three RJ-11 ports used to connect to the wall jack, the Router and if desired, a telephone or telephone device. The connection ports are typically labeled as follows:

Line - This port connects to the wall jack.

ADSL – This port connects to the Router.

Phone – This port connects to a telephone or other telephone device.

The diagram below illustrates the proper use of the splitter.

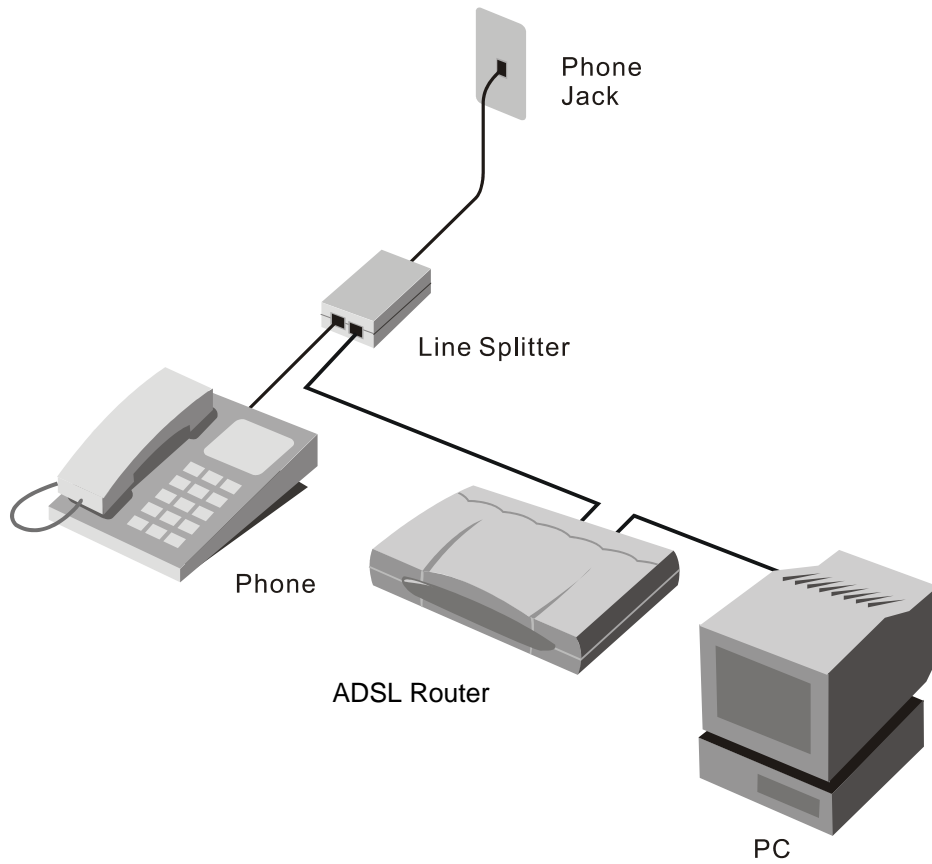

Line Splitter Installation

D-Link Offices

Australia	D-Link Australia 1 Giffnock Avenue, North Ryde, NSW 2113, Sydney, Australia TEL: 61-2-8899-1800 FAX: 61-2-8899-1868 TOLL FREE (Australia): 1800-177100 URL: www.dlink.com.au E-MAIL: support@dlink.com.au
Brazil	D-Link Brasil Ltda. Edificio Manoel Tabacow Hydal, Rua Tavares Cabral 102 Sala 31, 05423-030 Pinheiros, Sao Paulo, Brasil TEL: (55 11) 3094 2910 to 2920 FAX: (55 11) 3094 2921 E-MAIL: efreitas@dlink.cl
Canada	D-Link Canada 2180 Winston Park Drive, Oakville, Ontario, L6H 5W1 Canada TEL: 1-905-829-5033 FAX: 1-905-829-5095 TOLL FREE: 1-800-354-6522 URL: www.dlink.ca FTP: ftp.dlinknet.com E-MAIL: techsup@dlink.ca
Chile	D-Link South America (Sudamérica) Isidora Goyenechea 2934 Of. 702, Las Condes Fono, 2323185, Santiago, Chile, S. A. TEL: 56-2-232-3185 FAX: 56-2-232-0923 URL: www.dlink.cl E-MAIL: ccasassu@dlink.cl & tsilva@dlink.cl
China	D-Link China 15 th Floor, Science & Technology Tower, No.11, Baishiqiao Road, Haidan District, 100081 Beijing, China TEL: 86-10-68467106 FAX: 86-10-68467110 URL: www.dlink.com.cn E-MAIL: liweii@digitalchina.com.cn
Denmark	D-Link Denmark Naverland Denmark, Naverland 2, DK-2600 Glostrup, Copenhagen, Denmark TEL: 45-43-969040 FAX: 45-43-424347 URL: www.dlink.dk E-MAIL: info@dlink.dk
Egypt	D-Link Middle East 7 Assem Ebn Sabet Street, Heliopolis, Cairo, Egypt TEL: 202-245-6176 FAX: 202-245-6192 URL: www.dlink-me.com E-MAIL: support@dlink-me.com & fateen@dlink-me.com
Finland	D-Link Finland Pakkalankuja 7A, FIN-0150 Vantaa, Finland TEL: 358-9-2707-5080 FAX: 358-9-2707-5081 URL: www.dlink-fi.com
France	D-Link France Le Florilege, No. 2, Allée de la Fresnerie, 78330 Fontenay-le-Fleury, France TEL: 33-1-3023-8688 FAX: 33-1-3023-8689 URL: www.dlink-france.fr E-MAIL: info@dlink-france.fr

- Germany** **D-Link Central Europe (D-Link Deutschland GmbH)**
Schwalbacher Strasse 74, D-65760 Eschborn, Germany
TEL: 49-6196-77990 FAX: 49-6196-7799300
URL: www.dlink.de
BBS: 49-(0) 6192-971199 (analog)
BBS: 49-(0) 6192-971198 (ISDN)
INFO: 00800-7250-0000 (toll free)
HELP: 00800-7250-4000 (toll free)
REPAIR: 00800-7250-8000 E-MAIL: info@dlink.de
- India** **D-Link India**
Plot No.5, Bandra-Kurla Complex Rd., Off Cst Rd.,
Santacruz (East), Mumbai, 400 098 India
TEL: 91-022-652-6696/6578/6623
FAX: 91-022-652-8914/8476
URL: www.dlink-india.com & www.dlink.co.in
E-MAIL: service@dlink.india.com & tushars@dlink-india.com
- Italy** **D-Link Mediterraneo Srl/D-Link Italia**
Via Nino Bonnet n. 6/B, 20154, Milano, Italy
TEL: 39-02-2900-0676 FAX: 39-02-2900-1723
URL: www.dlink.it E-MAIL: info@dlink.it
- Japan** **D-Link Japan**
10F, 8-8-15 Nishi-Gotanda, Shinagawa-ku, Tokyo 141, Japan
TEL: 81-3-5434-9678 FAX: 81-3-5434-9868
URL: www.d-link.co.jp E-MAIL: kida@d-link.co.jp
- Netherlands** **D-Link Benelux**
Fellenoord 130 5611 ZB, Eindhoven, The Netherlands
TEL: 31-40-2668713 FAX: 31-40-2668666
URL: www.d-link-benelux.nl & www.dlink-benelux.be
E-MAIL: info@dlink-benelux.nl & info@dlink-benelux.be
- Norway** **D-Link Norway**
Waldemar Thranesgate 77, 0175 Oslo, Norway
TEL: 47-22-99-18-90 FAX: 47-22-20-70-39 SUPPORT: 800-10-610
URL: www.dlink.no
- Russia** **D-Link Russia**
Michurinski Prospekt 49, 117607 Moscow, Russia
TEL: 7-095-737-3389 & 7-095-737-3492
FAX: 7-095-737-3390 URL: www.dlink.ru
E-MAIL: vl@dlink.ru
- Singapore** **D-Link International**
1 International Business Park, #03-12 The Synergy,
Singapore 609917
TEL: 6-6774-6233 FAX: 6-6774-6322
E-MAIL: info@dlink.com.sg URL: www.dlink-intl.com
- South Africa** **D-Link South Africa**
Unit 2, Parkside, 86 Oak Avenue, Highveld Technopark,
Centurion, Gauteng, South Africa
TEL: 27-12-665-2165 FAX: 27-12-665-2186
URL: www.d-link.co.za E-MAIL: attie@d-link.co.za
- Spain** **D-Link Iberia (Spain and Portugal)**
Sabino de Arana, 56 bajos, 08028 Barcelona, Spain
TEL: 34 93 409 0770 FAX: 34 93 491 0795
URL: www.dlink.es E-MAIL: info@dlink.es

Sweden**D-Link Sweden**

P. O. Box 15036, S-167 15 Bromma, Sweden
TEL: 46-8-564-61900 FAX: 46-8-564-61901
URL: www.dlink.se E-MAIL: info@dlink.se

Taiwan**D-Link Taiwan**

2F, No. 119 Pao-chung Road, Hsin-tien, Taipei, Taiwan
TEL: 886-2-2910-2626 FAX: 886-2-2910-1515
URL: www.dlinktw.com.tw E-MAIL: dssqa@tsc.dlinktw.com.tw

Turkey**D-Link Middle East**

Deniz Bilgisayar, Buyukdere Cad. Naci Kasim Sk., No. 5
Mecidiyekoy, Istanbul, Turkey
TEL: 90-212-213-3400 FAX: 90-212-213-3420
E-MAIL: smorovati@dlink-me.com

U.A.E.**D-Link Middle East**

CHS Aptec (Dubai), P.O. Box 33550 Dubai, United Arab Emirates
TEL: 971-4-366-885 FAX: 971-4-355-941
E-MAIL: Wxavier@dlink-me.com

U.K.**D-Link Europe (United Kingdom) Ltd**

4th Floor, Merit House, Edgware Road, Colindale, London
NW9 5AB United Kingdom
TEL: 44-020-8731-5555 SALES: 44-020-8731-5550
FAX: 44-020-8731-5511 SALES: 44-020-8731-5551
URL: www.dlink.co.uk E-MAIL: info@dlink.co.uk

U.S.A.**D-Link U.S.A.**

17575 Mt. Herrmann, Fountain Valley, CA 92708
TEL: 1-714-885-6000 FAX: 1-866-743-4905
INFO: 1-800-326-1688 URL: www.dlink.com
E-MAIL: tech@dlink.com & support@dlink.com