

**D-Link®**

POWERLINE AV 500 NETWORK STARTER KIT  
DHP-501AV

**QUICK  
INSTALLATION  
GUIDE**

РУКОВОДСТВО ПО БЫСТРОЙ УСТАНОВКЕ

GUÍA DE INSTALACIÓN RÁPIDA

GUIA DE INSTALAÇÃO RÁPIDA

快速安裝指南

PETUNJUK PEMASANGAN CEPAT

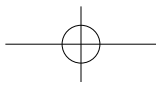
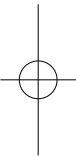
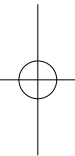

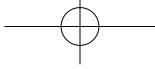

ENGLISH

# CONTENTS OF PACKAGING

## CONTENTS

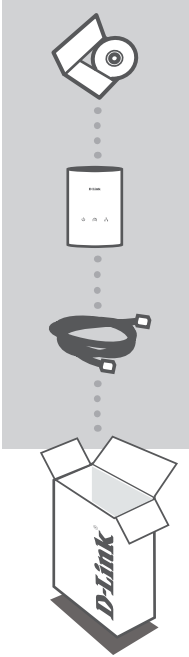

### **INSTALLATION CD**

INCLUDES SETUP WIZARD & USER MANUAL

### **POWERLINE AV 500 ADAPTER X2**

DHP-500AV X2

### **ETHERNET CABLE (CAT5 UTP) X2**

CONNECTS THE DEVICE TO YOUR NETWORK

If any of these items are missing from your packaging, contact your reseller.

# PRODUCT SETUP

ENGLISH

## INSTALLATION STEPS

### ROOM A

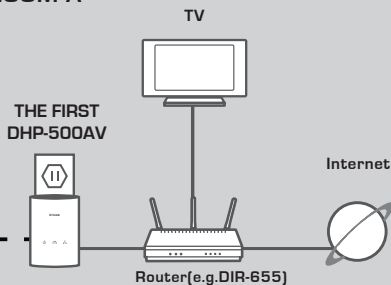

### SET-UP THE FIRST DHP-500AV

Plug the first DHP-500AV into an AC wall outlet close to your router and connect the included CAT5 Ethernet cable to the Ethernet jack of the first DHP-500AV to your router as seen in Room A.

### Existing Wall Wiring

### ROOM B

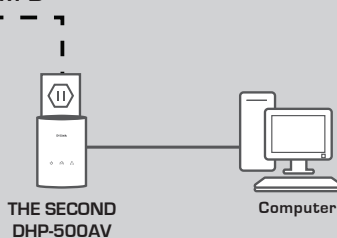

### SET-UP THE SECOND DHP-500AV

1. Plug the second DHP-500AV into an AC wall outlet of the room where you want to extend your home network as seen in Room B.
2. Connect one end of the supplied CAT5 Ethernet cable to the Ethernet port of the second DHP-500AV and the other end of the cable to the Ethernet port of your computer.

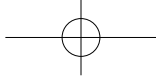

# TROUBLESHOOTING

## SET-UP AND CONFIGURATION PROBLEMS

### 1. CAN I SECURE MY POWERLINE NETWORK WITHOUT USING ANY SOFTWARE?

Yes the DHP-500AV features a push-button encryption technology to allow you to protect your network easily. Please refer to the DHP-500AV Manual supplied on the CD-ROM for setup instructions.

### 2. WHEN I PLUGGED IN MY DEVICES, THEY WERE ABLE TO SEE EACH OTHER AND CONNECT AUTOMATICALLY. WHAT IS THE SOFTWARE FOR?

By default, your DHP-500AV is configured to work out of the box once plugged in and connected to your router. However the software allows you further options to check the quality of your connection, secure your network, and manage the devices.

### 3. MY NETWORK SEEMS TO BE PERFORMING SLOWER THAN EXPECTED. HOW CAN I IMPROVE THIS?

**PLEASE ENSURE THE FOLLOWING TO ENSURE BEST NETWORK PERFORMANCE.**

- Plug the DHP-500AV's directly into a wall socket and not into a power strip since some power strips have surge protectors that may block power line signals.
- If this is not possible, then try plugging the device/s into a different power strip that is less populated.
- Check that there are no other interfering appliances plugged into the same power strip, particularly mobile phone chargers or hair dryers as Powerline networks are very sensitive to electrical interference.

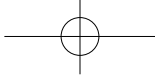

## TECHNICAL SUPPORT

ENGLISH

You can find software updates and user documentation on the D-Link website.

### Tech Support for customers in

#### Australia:

Tel: 1300-766-868  
24/7 Technical Support  
Web: <http://www.dlink.com.au>  
E-mail: [support@dlink.com.au](mailto:support@dlink.com.au)

#### India:

Tel: 1800-233-0000 (MTNL & BSNL Toll Free)  
+91-832-2885700 (GSM, CDMA & Others)  
Web: [www.dlink.co.in](http://www.dlink.co.in)  
E-Mail: [helpdesk@dlink.co.in](mailto:helpdesk@dlink.co.in)

#### Singapore, Thailand, Indonesia, Malaysia, Philippines, Vietnam:

Singapore - [www.dlink.com.sg](http://www.dlink.com.sg)  
Thailand - [www.dlink.co.th](http://www.dlink.co.th)  
Indonesia - [www.dlink.co.id](http://www.dlink.co.id)  
Malaysia - [www.dlink.com.my](http://www.dlink.com.my)  
Philippines - [www.dlink.com.ph](http://www.dlink.com.ph)  
Vietnam - [www.dlink.com.vn](http://www.dlink.com.vn)

#### Korea:

Tel : +82-2-2028-1810  
Monday to Friday 9:00am to 6:00pm  
Web : <http://d-link.co.kr>  
E-mail : [g2b@d-link.co.kr](mailto:g2b@d-link.co.kr)

#### New Zealand:

Tel: 0800-900-900  
24/7 Technical Support  
Web: <http://www.dlink.co.nz>  
E-mail: [support@dlink.co.nz](mailto:support@dlink.co.nz)

#### South Africa and Sub Sahara Region:

Tel: +27-12-665-2165  
08600 DLINK (for South Africa only)  
Monday to Friday 8:30am to 9:00pm South Africa Time  
Web: <http://www.d-link.co.za>  
E-mail: [support@d-link.co.za](mailto:support@d-link.co.za)

#### Saudi Arabia (KSA):

Tel: +966 01 217 0008  
Fax: +966 01 217 0009  
Saturday to Wednesday 9.30AM to 6.30PM  
Thursdays 9.30AM to 2.00 PM  
E-mail: [Support.sa@dlink-me.com](mailto:Support.sa@dlink-me.com)

#### D-Link Middle East - Dubai, U.A.E.

Plot No. S31102,  
Jebel Ali Free Zone South,  
P.O.Box 18224, Dubai, U.A.E.  
Tel: +971-4-8809022  
Fax: +971-4-8809066 / 8809069  
Technical Support: +971-4-8809033  
General Inquiries: [info.me@dlink-me.com](mailto:info.me@dlink-me.com)  
Tech Support: [support.me@dlink-me.com](mailto:support.me@dlink-me.com)

#### Egypt

1, Makram Ebeid Street - City Lights Building  
Nasrcity - Cairo, Egypt  
Floor 6, office C2  
Tel.: +2 02 26718375 - +2 02 26717280  
Technical Support: +2 02 26738470  
General Inquiries: [info.eg@dlink-me.com](mailto:info.eg@dlink-me.com)  
Tech Support: [support.eg@dlink-me.com](mailto:support.eg@dlink-me.com)

#### Kingdom of Saudi Arabia

Office # 84 ,  
Al Khaleej Building ( Mujamathu Al-Khaleej)  
Opp. King Fahd Road, Olaya  
Riyadh - Saudi Arabia  
Tel: +966 1 217 0008  
Technical Support:  
+966 1 2170009 / +966 2 6522951  
General Inquiries: [info.sa@dlink-me.com](mailto:info.sa@dlink-me.com)  
Tech Support: [support.sa@dlink-me.com](mailto:support.sa@dlink-me.com)

#### Pakistan

Islamabad Office:  
61-A, Jinnah Avenue, Blue Area,  
Suite # 11, EBC, Saudi Pak Tower,  
Islamabad - Pakistan  
Tel.: +92-51-2800397, 2800398  
Fax: +92-51-2800399

#### Karachi Office:

D-147/1, KDA Scheme # 1,  
Opposite Mudassir Park, Karsaz Road,  
Karachi – Pakistan  
Phone: +92-21-34548158, 34326649  
Fax: +92-21-4375727  
Technical Support: +92-21-34548310, 34305069  
General Inquiries: [info.pk@dlink-me.com](mailto:info.pk@dlink-me.com)  
Tech Support: [support.pk@dlink-me.com](mailto:support.pk@dlink-me.com)

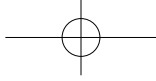

## TECHNICAL SUPPORT

**Iran**

Unit 5, 5th Floor, No. 20, 17th Alley , Bokharest  
St. , Argentine Sq. ,  
Tehran IRAN  
Postal Code : 1513833817  
Tel: +98-21-88880918,19  
+98-21-88706653,54  
General Inquiries: info.ir@dlink-me.com  
Tech Support: support.ir@dlink-me.com

**ISRAEL**

מטלון סנטר  
רח' המגשימים 20  
קריית מטלון, פתח-תקווה 49348  
פתח-תקווה, ת"ד 7060, link-D.  
טלפונים: 073-277-11-77

**Morocco**

M.I.T.C  
Route de Nouaceur angle RS et CT 1029  
Bureau N° 312 ET 337  
Casablanca , Maroc  
Phone : +212 663 72 73 24  
Email: support.na@dlink-me.com

**Lebanon RMA center**

Dbayeh/Lebanon  
PO Box:901589  
Tel: +961 4 54 49 71 Ext:14  
Fax: +961 4 54 49 71 Ext:12  
Email: taoun@dlink-me.com

**Bahrain**

Technical Support: +973 1 3332904

**Kuwait:**

Technical Support: + 965 22453939 / +965  
22453949

**Türkiye Merkez İrtibat Ofisi**

Ayazağa Maslak yolu  
Erdebil Cevahir İş Merkezi No: 5/A Ayazağa /  
Maslak İstanbul  
Tel: +90 212 2895659  
Ücretsiz Müşteri Destek Hattı: 0 800 211 00 65  
Web:www.dlink.com.tr  
Teknik Destek: support.tr@dlink.com.tr

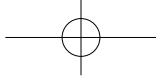

NOTES

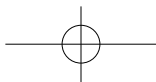
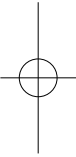
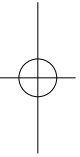

# КОМПЛЕКТ ПОСТАВКИ

## СОДЕРЖИМОЕ

РУССКИЙ

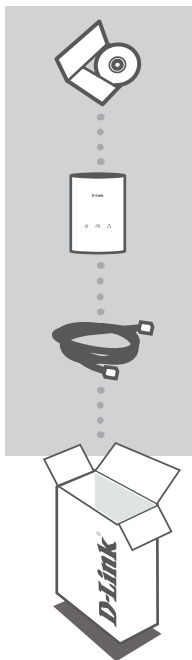

### УСТАНОВОЧНЫЙ CD-ДИСК

СОДЕРЖИТ МАСТЕР УСТАНОВКИ И РУКОВОДСТВО ПОЛЬЗОВАТЕЛЯ

### POWERLINE AV 500 ADAPTER X2

DHP-500AV X2

### КАБЕЛЬ ETHERNET (CAT5 UTP) X2

ПОДКЛЮЧЕНИЕ УСТРОЙСТВА К СЕТИ

Если что-либо из перечисленного отсутствует, пожалуйста, обратитесь к поставщику



# УСТАНОВКА

## ШАГИ ПО УСТАНОВКЕ

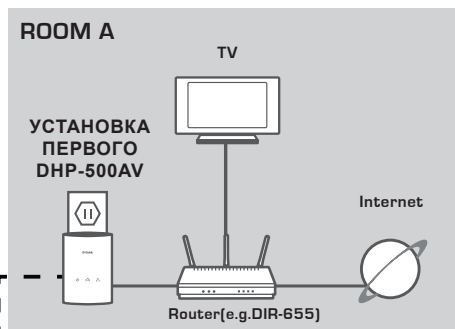

Existing Wall Wiring

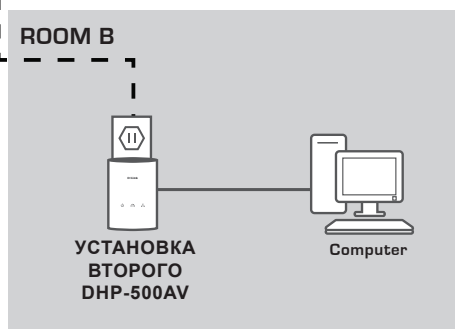

### УСТАНОВКА ПЕРВОГО DHP-500AV

Подключите первый DHP-500AV к настенной розетке переменного тока рядом с маршрутизатором и подключите кабель Ethernet 5 категории из комплекта поставки от разъема Ethernet на первом DHP-500AV к маршрутизатору, как показано в комнате А.

### УСТАНОВКА ВТОРОГО DHP-500AV

1. Подключите второй DHP-500AV к настенной розетке переменного тока в комнате, где необходимо расширить домашнюю сеть, как показано в комнате В.
2. Подключите один конец кабеля Ethernet 5 категории из комплекта поставки к порту Ethernet на втором DHP-500AV, и другой конец кабеля к порту Ethernet на компьютере. Ethernet на компьютере.

РУССКИЙ

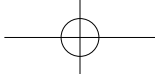

# ПОИСК И УСТРАНЕНИЕ НЕИСПРАВНОСТЕЙ

## ПРОБЛЕМЫ С УСТАНОВКОЙ И НАСТРОЙКОЙ

### 1. МОЖНО ЛИ ЗАЩИТИТЬ СЕТЬ POWERLINE БЕЗ ИСПОЛЬЗОВАНИЯ ПРОГРАММНОГО ОБЕСПЕЧЕНИЯ?

Да. DHP-500AV оснащен кнопкой активации шифрования для защиты сети. За инструкцией по настройке, пожалуйста, обратитесь к руководству пользователя DHP-500AV на компакт-диске.

### 2. ПОСЛЕ ПОДКЛЮЧЕНИЯ УСТРОЙСТВ ОНИ МОГУТ ВИДЕТЬ ДРУГ ДРУГА И ПОДКЛЮЧАТЬСЯ АВТОМАТИЧЕСКИ. ДЛЯ ЧЕГО ТРЕБУЕТСЯ ПРОГРАММНОЕ ОБЕСПЕЧЕНИЕ?

По умолчанию DHP-500AV сразу настроен для автоматического подключения к сети и маршрутизатору. Однако программное обеспечение представляет такие функциональные возможности как проверка качества соединения, безопасность сети, и управление устройствами.

### 3. СЕТЬ РАБОТАЕТ МЕДЛЕННЕЕ, ЧЕМ ОЖИДАЛОСЬ. КАК МОЖНО ПОВЫСИТЬ ЕЕ ПРОИЗВОДИТЕЛЬНОСТЬ?

Пожалуйста, убедитесь, что для обеспечения наилучшей производительности выполнено следующее:

- Подключите DHP-500AV непосредственно к настенной розетке питания, а не к сетевому удлинителю, т.к. некоторые удлинители могут быть оснащены сетевыми фильтрами, которые могут блокировать сигналы линии питания.
- Если это невозможно, попытайтесь подключить устройство/устройства к другому удлинителю с наибольшим количеством свободных розеток.
- Убедитесь, что в этот же удлинитель не подключены бытовые приборы создающие интерференцию, особенно зарядные устройства для мобильных телефонов или фены для волос, т.к. сети Powerline очень чувствительны к электрической интерференции.



## ТЕХНИЧЕСКАЯ ПОДДЕРЖКА

Обновления программного обеспечения и документация доступны на Интернет-сайте D-Link. D-Link предоставляет бесплатную поддержку для клиентов в течение гарантийного срока. Клиенты могут обратиться в группу технической поддержки D-Link по телефону или через Интернет.

### Техническая поддержка D-Link:

+7(495) 744-00-99

### Техническая поддержка через Интернет

<http://www.dlink.ru>

e-mail: [support@dlink.ru](mailto:support@dlink.ru)

## MORE BRANCHES

### Украина,

04080 г. Киев , ул. Межигорская, 87-А, офис 18  
Тел.: +38 (044) 545-64-40  
E-mail: [kiev@dlink.ru](mailto:kiev@dlink.ru)

### Беларусь

220114, г. Минск, проспект Независимости,  
169 , БЦ "XXI Век"  
Тел.: +375(17) 218-13-65  
E-mail: [minsk@dlink.ru](mailto:minsk@dlink.ru)

### Казахстан,

050008, г. Алматы, ул. Курмангазы, дом 143  
(уг. Муқанова)  
Тел./факс: +7 727 378-55-90  
E-mail: [almaty@dlink.ru](mailto:almaty@dlink.ru)

### Узбекистан

100015, г.Ташкент, ул. Нукуская, 89  
Тел./Факс: +998 (71) 120-3770, 150-2646  
E-mail: [tashkent@dlink.ru](mailto:tashkent@dlink.ru)

### Армения

0038, г. Ереван, ул. Абеяна, 6/1, 4 этаж  
Тел./Факс: + 374 (10) 398-667  
E-mail: [erevan@dlink.ru](mailto:erevan@dlink.ru)

### Грузия

0162, г. Тбилиси,  
проспект Чавчавадзе 74, 10 этаж  
Тел./Факс: + 995 (32) 244-563

### Lietuva

09120, Vilnius, Žirmūnų 139-303  
Tel./faks. +370 (5) 236-3629  
E-mail: [info@dlink.lt](mailto:info@dlink.lt)

### Eesti

Peterburi tee 46-205  
11415, Tallinn, Eesti , Susi Bürookeskus  
tel +372 613 9771  
e-mail: [info@dlink.ee](mailto:info@dlink.ee)

### Latvija

Mazā nometņu 45/53 (ieeja no Nāras ielas)  
LV-1002, Rīga  
tel.: +371 6 7618703 +371 6 7618703  
e-pasts: [info@dlink.lv](mailto:info@dlink.lv)

ESPAÑOL

# CONTENIDOS DEL PAQUETE

## CONTENIDO

ESPAÑOL

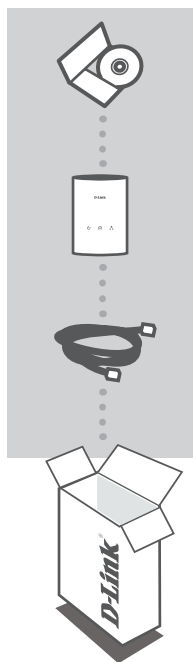

### CD DE INSTALACION

Incluye Setup Wizard y Manual de Usuario

### POWERLINE AV 500 ADAPTER X2

DHP-500AV X2

### CABLE ETHERNET (CAT5 UTP) X2

Conecte el dispositivo a su red

Si alguno de los artículos no se encuentra, por favor contáctese con su vendedor

# CONFIGURACIÓN DEL DISPOSITIVO

## PASOS DE INSTALACION

### ROOM A

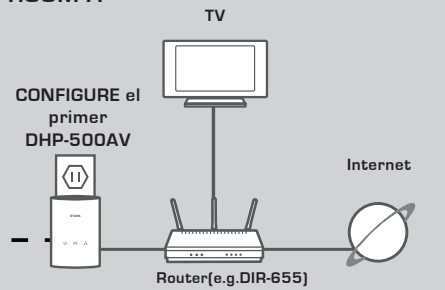

Existing Wall Wiring

### ROOM B

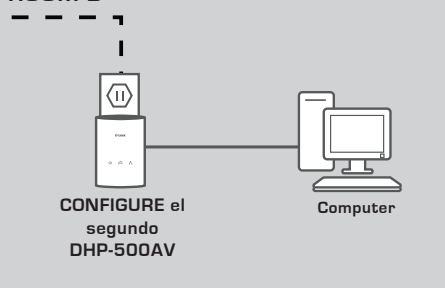

### CONFIGURE EL PRIMER DHP-500AV

Conecte el primer DHP-500AV en una toma de corriente cerca de su router y conecte el cable ethernet CAT5 al puerto ethernet del primer DHP-500AV al router como se ve en la Habitación A.

ESPAÑOL

### CONFIGURE EL SEGUNDO DHP-500AV

1. Conecte el segundo DHP-500AV a una toma de corriente de la sala donde quiera extender la red local como se muestra en la Habitación B.
2. Conecte un extremo del cable Ethernet CAT5 al puerto ethernet del segundo DHP-500AV y el otro extremo del cable al puerto Ethernet de su computador.

# SOLUCIÓN DE PROBLEMAS

## PROBLEMAS DE INSTALACIÓN Y CONFIGURACIÓN

### 1. ¿PUEDO ASEGURAR MI RED POWERLINE SIN UTILIZAR SOFTWARE?

Sí. El DHP-500AV incorpora una tecnología de cifrado que permite proteger fácilmente su red pulsando un botón. Consulte el Manual de DHP-500AV suministrado en el CD-ROM para ver las instrucciones de configuración.

### 2. SI CUANDO CONECTO MIS DISPOSITIVOS, PUEDEN VERSE ENTRE ELLOS Y CONECTARSE AUTOMÁTICAMENTE, ¿PARA QUÉ SIRVE EL SOFTWARE?

Por defecto, el DHP-500AV está configurado para funcionar con solo enchufarlo y conectarlo al router. Sin embargo, el software ofrece otras opciones: comprobar la calidad de su conexión, hacer la red segura, y gestionar los dispositivos.

### 3. PARECE QUE LA RED FUNCIONA MÁS LENTAMENTE DE LO PREVISTO. ¿CÓMO PUEDO SOLUCIONARLO?

Para garantizar el máximo rendimiento, realice lo siguiente:

- Conecte el DHP-500AV directamente a una base de pared y no a una regleta de alimentación, puesto que algunas regletas de alimentación disponen de protectores de sobretensión que pueden bloquear las señales de la línea eléctrica.
- Si no es posible, conecte los dispositivos en una regleta de alimentación más vacía.
- Compruebe que, en la misma regleta de alimentación, no hay otros elementos conectados que puedan causar interferencias, en especial cargadores de teléfonos móviles o secadores de pelo, puesto que las redes Powerline son muy sensibles a las interferencias eléctricas.

## SOPORTE TÉCNICO

Usted puede encontrar actualizaciones de softwares o firmwares y documentación para usuarios a través de nuestro sitio [www.dlinkla.com](http://www.dlinkla.com)

### SOPORTE TÉCNICO PARA USUARIOS EN LATINO AMERICA

SopORTE técnico a través de los siguientes teléfonos de D-Link

PAIS	NUMERO
Argentina	0800 - 12235465
Chile	800 - 835465 ó (02) 5941520
Colombia	01800 - 9525465
Costa Rica	0800 - 0521478
Ecuador	1800 - 035465
El Salvador	800 - 6335
Guatemala	1800 - 8350255
México	01800 - 1233201
Panamá	011 008000525465
Perú	0800 - 00968
Venezuela	0800 - 1005767

### SopORTE Técnico de D-Link a través de Internet

Horario de atención SopORTE Técnico en [www.dlinkla.com](http://www.dlinkla.com)  
e-mail: [sopORTE@dlinkla.com](mailto:sopORTE@dlinkla.com) & [consultas@dlinkla.com](mailto:consultas@dlinkla.com)

# CONTEÚDO DA EMBALAGEM

## CONTEÚDO

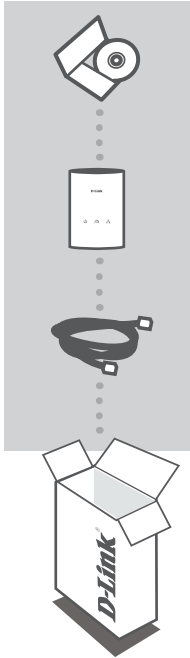

### CD DE INSTALAÇÃO

INCLUI SETUP WIZARD & MANUAL DO USUÁRIO

### POWERLINE AV 500 ADAPTER X2

DHP-500AV X2

### CABO ETHERNET (CAT5 UTP) X2

CONECTE O DISPOSITIVO NA SUA REDE

Se qualquer desses itens não estiver contido na sua embalagem, entre em contato com o seu revendedor.

PORTUGUÊS

# CONFIGURAÇÃO DO PRODUTO

## INSTALAÇÃO PASSO A PASSO

### ROOM A

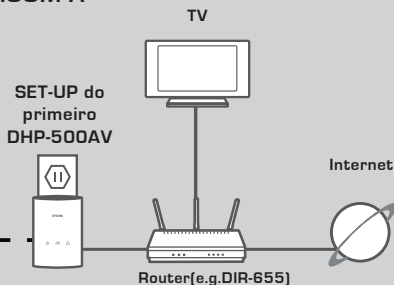

### SET-UP DO PRIMEIRO DHP-500AV

Conecte o primeiro DHP-500AV em uma tomada de parede próxima ao seu roteador e conecte o cabo Ethernet CAT5 à entrada Ethernet do primeiro DHP-500AV ao seu roteador, como visto no quadro A.

### Existing Wall Wiring

### ROOM B

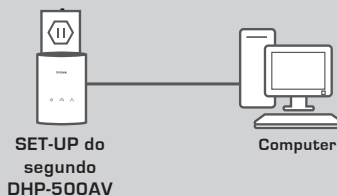

### SET-UP DO SEGUNDO DHP-500AV

1. Conecte o segundo DHP-500AV a uma tomada AC do local onde você deseja estender sua rede doméstica, como visto no quadro B.
2. Conecte uma extremidade do cabo CAT5 Ethernet fornecido à porta Ethernet do segundo DHP-500AV e a outra extremidade do cabo à porta Ethernet do seu computador.





# RESOLUÇÃO DE PROBLEMAS

## SET-UP E PROBLEMAS DE CONFIGURAÇÃO

### 1. POSSO PROTEGER A MINHA REDE POWERLINE SEM UTILIZAR QUALQUER SOFTWARE?

Sim. O DHP-500AV tem como característica uma tecnologia de encriptação com botão que lhe permite proteger a sua rede facilmente. Para instruções de instalação, consulte o Manual do DHP-500AV fornecido no CD-ROM.

### 2. QUANDO LIGUEI OS MEUS DISPOSITIVOS ESTES CONSEGUIAM VER-SE E LIGAR-SE AUTOMATICAMENTE. PARA QUE SERVE O SOFTWARE?

Por pré-definição, o seu DHP-500AV está configurado para trabalhar assim que for ligado ao seu router. No entanto, o software permite-lhe seleccionar mais opções para verificar a qualidade da sua ligação, segurar a sua rede, e gerir os dispositivos.

### 3. A MINHA REDE PARECE ESTAR MAIS LENTA DO QUE O ESPERADO. COMO POSSO MELHORAR A VELOCIDADE DA REDE?

Verifique as seguintes situações para garantir o melhor desempenho possível da rede.

- Ligue o DHP-500AV directamente a uma tomada de parede e não a um cabo de alimentação, uma vez que alguns cabos de alimentação têm protecções de sobre tensão que podem bloquear os sinais da linha de potência.
- Se não for possível, tente ligar o(s) dispositivo(s) a um cabo de alimentação diferente que seja menos utilizado
- Verifique se não existem outros dispositivos com interferências ligados ao mesmo cabo de alimentação, sobretudo carregadores de telemóvel ou secadores de cabelo, porque as redes Powerline são muito sensíveis a interferências eléctricas.

## SUPOORTE TÉCNICO

Caso tenha dúvidas na instalação do produto, entre em contacto com o Suporte Técnico D-Link por:

#### Chat Online

[www.dlink.com.br/suporte](http://www.dlink.com.br/suporte)

#### E-mail

[suporte@dlink.com.br](mailto:suporte@dlink.com.br)

#### Back Office

[backoffice@dlink.com.br](mailto:backoffice@dlink.com.br) \*

\*Acionar Garantia para 4 ou mais equipamentos

#### Telefones

São Paulo: (11) 2755-6950

\*GO: 4052-1850 (Ligação local)

\*Nordeste: 0800-7024104

\*Demais Estados: 4062-1850 (Ligação local)

\*Apenas Modems ADSL

Garantia diferenciada vendida pela internet. Agilidade e tranquilidade para suas atividades!

Conheça: <http://garantiapremium.dlink.com.br>

**Atendimento disponível das 9h as 21h de segunda a sexta feira e aos sábados das 9h as 15h**

DHP-501AV

**D-Link**

17

PORTUGUÊS

# 包裝內容物

## 內容

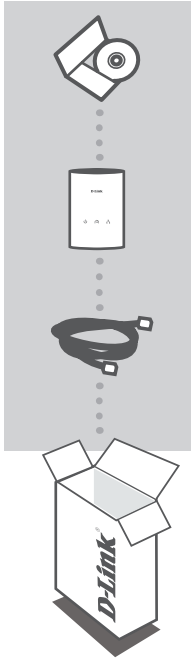

### 安裝光碟

內含安裝設定精靈與使用手冊

### POWERLINE AV 500 ADAPTER X2

DHP-500AV X2

### 乙太網路線 (CAT5 UTP) X2

將設備連接至您的網路

若上述有任一品項缺漏請立即聯絡您的經銷商

中  
文

# 產品設定

## 安裝步驟

### ROOM A

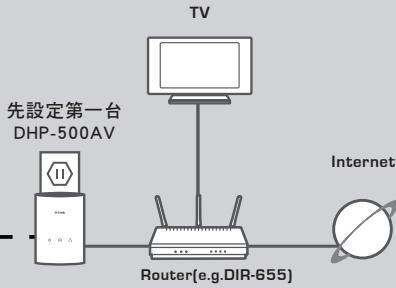

### Existing Wall Wiring

### ROOM B

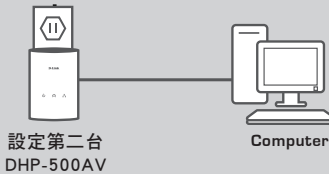

### 先設定第一台DHP-500AV

將第一台DHP-500AV 連接至靠近您寬頻路由器旁牆壁上的AC電源插座,然後使用一條CAT5網路線連接於DHP-500AV的網路埠,並將網路線另外一端連接至寬頻路由器,如同房間A所示。

### 設定第二台DHP-500AV

- 1.將第二台DHP-500AV連接至您所想透過電力迴路延伸網路環境房間的電源插座,如同房間B所示。
- 2.使用CAT5網路線連接於DHP-500AV的網路埠,並將網路線另外一端連接至您的電腦。

中  
文

# 故障排除

## 設定與組態問題

1. 請問我是否可以不用透過任何的軟體設定電源線網路橋接器的安全連線？  
可以的,DHP-500AV具備可以透過”push-button”設定加密的機制，您只要簡單的透過按下設備上的按鍵就可以輕鬆的完成網路連線。敬請參考DHP-500AV手冊中相關說明。
2. 當我將DHP-500AV安裝在電源插座上後就可以自動連線隨插即用，為何還需要安裝軟體？  
DHP-500AV在預設狀態下皆為同一個電力迴路群組,故可以直接互相連線不需作任何設定。而安裝軟體為可讓您確實的掌握所有DHP-500AV目前的連線狀態、連線品質與設定群組等功能。
3. 我的網路連線效能比預期的還差，我該如何改善？  
敬請確認下列事項以改善您的網路效能
  - 請直接將DHP-500AV安裝在牆壁上的電源插座,而不要經由電源延長線。因為部份電源延長線具備防突波保護裝置並且會阻斷電源線網路連線。
  - 假如您沒有上述的狀況,您可以在嘗試將DHP-500AV安裝其他的電源插座上，並確認是否可以順利使用電源線網路。
  - 確認是否有其他可能造成干擾的設備安裝在同一個電力線路環境中，例如行動電話充電器、吹風機等設備。請盡可能讓DHP-500AV在乾淨的電力環境中使用。

## D-Link 友訊科技 台灣分公司 技術支援資訊

中文

如果您還有任何本使用手冊無法協助您解決的產品相關問題，台灣地區用戶可以透過我們的網站、電子郵件或電話等方式與D-Link台灣地區技術支援工程師聯絡。

### D-Link 免付費技術諮詢專線

0800-002-615

服務時間：週一至週五，早上9:00到晚上9:00

(不含周六、日及國定假日)

網 站：<http://www.dlink.com.tw>

電子郵件：[dssqa\\_service@dlink.com.tw](mailto:dssqa_service@dlink.com.tw)

如果您是台灣地區以外的用戶，請參考D-Link網站，全球各地分公司的聯絡資訊以取得相關支援服務。

產品保固期限、台灣區維修據點查詢，請參考以下網頁說明：

<http://www.dlink.com.tw>

產品維修：

使用者可直接送至全省聯強直營維修站或請洽您的原購買經銷商。

# ISI PAKET

## ISI

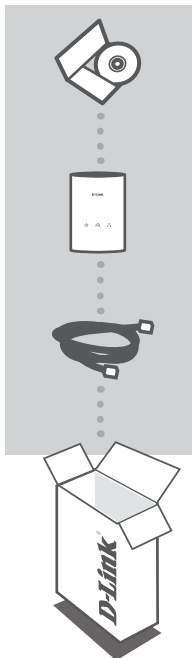

### CD INSTALASI

Termasuk Wizard untuk memasang dan Petunjuk Teknis Penggunaan

### POWERLINE AV 500 ADAPTER X2

DHP-500AV X2

### KABEL ETHERNET (CAT5 UTP) X2

HUBUNGAN PERANGKAT KE JARINGAN ANDA

Jika ada item-item diatas yang hilang, hubungi penjual

BAHASA INDONESIA

# PEMASANGAN PRODUK

## LANGKAH-LANGKAH PEMASANGAN

### ROOM A

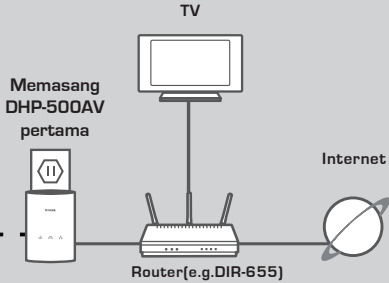

### MEMASANG DHP-500AV PERTAMA

Colok DHP-500AV pertama ke colokan listrik AC yang dekat dengan router anda dan hubungkan kabel Ethernet CAT5 yang termasuk dalam paket penjualan dari port Ethernet DHP-500AV pertama ke router anda seperti yang terlihat dalam Ruangan A.

### ROOM B

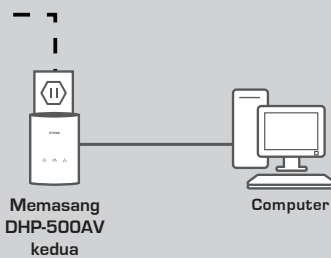

### MEMASANG DHP-500AV KEDUA

1. Colok DHP-500AV kedua ke colokan listrik AC diruangan dimana anda ingin perluas jaringan rumah anda seperti yang terlihat dalam Ruangan B.
2. Hubungkan salah satu ujung dari kabel Ethernet CAT5 yang disediakan ke port Ethernet dari DHP-500AV dan ujung satunya lagi ke port Ethernet pada komputer anda.



# PENYELESAIAN MASALAH YANG UMUM DITEMUI

## MASALAH DALAM PEMASANGAN DAN PENGATURAN.

### 1. APAKAH SAYA DAPAT MENGAMANKAN JARINGAN POWERLINE SAYA TANPA MENGGUNAKAN PROGRAM APAPUN?

Ya. DHP-500AV mempunyai fitur teknologi enkripsi melalui tombol yang mengijinkan anda untuk mengamankan jaringan anda dengan mudah. Silahkan mengacu pada Petunjuk Penggunaan DHP-500AV yang ada pada CD untuk instruksi pemasangan.

### 2. KETIKA SAYA MEMASANG PERALATAN INI, MEREKA LANGSUNG BISA SALING MELIHAT DAN TERHUBUNG SECARA OTOMATIS. JADI APAKAH KEGUNAAN DARI PERANGKAT LUNAK UTILITI?

Secara default, DHP-500AV sudah diatur supaya dapat langsung bekerja ketika dikeluarkan dari kotaknya. Perangkat lunak utiliti digunakan untuk mengatur pilihan-pilihan yang lebih jauh lagi, melihat kualitas dari koneksi, mengamankan jaringan, dan mengatur peralatan ini.

### 3. PERFORMA JARINGAN SAYA LEBIH RENDAH DARI YANG SAYA HARAPKAN. BAGAIMANA MENINGKATKANNYA?

Lakukan langkah-langkah berikut ini untuk mendapatkan performa yang terbaik.

- Pasang DHP-500AV langsung ke stopkontak pada dinding dan jangan ke kabel ekstension karena karena beberapa kabel ekstension menimbulkan interferensi dan menggunakan surge protectors yang dapat menghalangi sinyal power line.
- Jika tidak memungkinkan, coba pasang alat ini pada kabel ekstension yang tidak terlalu penuh.
- Periksa bahwa tidak ada peralatan lain yang menyebabkan interferensi yang terpasang dalam kabel ekstension yang sama, khususnya handphone charger atau hairdryer karena jaringan Powerline sangat sensitive terhadap interferensi listrik.

## DUKUNGAN TEKNIS

Update perangkat lunak dan dokumentasi pengguna dapat diperoleh pada situs web D-Link. Dukungan Teknis untuk pelanggan:

### Dukungan Teknis D-Link melalui telepon:

Tel: +62-21-5731610

### Dukungan Teknis D-Link melalui Internet:

Email : [support@dlink.co.id](mailto:support@dlink.co.id)

Website : <http://support.dlink.co.id>

