



# User Manual

## Full HD Outdoor Fixed Dome Network Camera

DCS-6314

# Preface

D-Link reserves the right to revise this publication and to make changes in the content hereof without obligation to notify any person or organization of such revisions or changes. Information in this document may become obsolete as our services and websites develop and change.

## Manual Revisions

Revision	Date	Description
1.0	May 29, 2013	DCS-6314 Revision A1 with firmware version 1.00

## Trademarks

D-Link and the D-Link logo are trademarks or registered trademarks of D-Link Corporation or its subsidiaries in the United States or other countries. All other company or product names mentioned herein are trademarks or registered trademarks of their respective companies.

Copyright © 2013 D-Link Corporation.

All rights reserved. This publication may not be reproduced, in whole or in part, without prior expressed written permission from D-Link Corporation.

# Table of Contents

Product Overview.....	4	Setup .....	33
Package Contents.....	4	Setup Wizard .....	33
Introduction.....	5	Network Setup.....	39
System Requirements .....	5	Dynamic DNS .....	42
Features.....	6	Image Setup .....	43
Hardware Overview .....	7	Audio and Video.....	45
Front .....	7	Preset.....	47
Top.....	8	Motion Detection .....	49
Cable Harness.....	9	Time and Date.....	50
Internal .....	10	Event Setup.....	51
Assembly and Installation .....	11	SD Card .....	59
Installing a Micro SD Card.....	11	Advanced.....	60
Deploying the Camera.....	13	Digital Input/Output.....	60
Mounting the Camera.....	15	ICR and IR.....	61
Attaching the Camera to the Pendant Mount.....	18	HTTPS.....	62
Attaching the Camera to the Bent Mount .....	20	Access List.....	63
Orienting the Camera.....	22	Maintenance.....	64
Camera Installation Wizard .....	23	Device Management .....	64
General Connection Using 12 V DC Power		System .....	65
Adapter.....	23	Firmware Upgrade.....	66
Connection Using Power over Ethernet .....	24	Status .....	67
Software Installation.....	25	Device Info .....	67
D-ViewCam Setup Wizard.....	28	Logs .....	68
Configuration.....	30	Help.....	69
Using the Configuration Interface.....	30	DI/DO Specifications .....	70
Live Video .....	31	Technical Specifications .....	71

# Product Overview

## Package Contents



DCS-6314 Full HD Outdoor Fixed Dome Network Camera



CD-ROM with User Manual and software



Quick Installation Guide



Power adapter



Security Wrench



CAT5 Ethernet cable



Screws and wall socket



Weather Shield



4Pin Terminal Block

If any of the above items are missing, please contact your reseller.

**Note:** Using a power supply with a different voltage than the one included with your product will cause damage and void the warranty for this product.

## Introduction

The DCS-6314 Full HD Outdoor Fixed Dome Network Camera is a professional surveillance and security solution for small, medium, and large enterprises alike. The DCS-6314 uses a 2 megapixel progressive scan CMOS sensor which produces high quality images with low noise, making it ideal for surveillance applications. Together with the WDR enhancement, users can identify image details in both extremely bright as well as dark environments.

The DCS-6314 has an IP68 certified weatherproof housing designed for both indoor and outdoor applications. The built-in removable IR-cut filter and IR LEDs give the DCS-6314 the capability to view up to 15 meters at night. The ability to use Power over Ethernet (PoE) also allows it to be easily installed in a variety of locations without the need for supplemental power cabling. The combination of IP68 housing, IR-Cut Filter, IR LEDs and PoE make the DCS-6314 an ideal solution for a high performance, reliable and cost-effective 24 hour megapixel surveillance solution with an easy clutter-free installation.

## System Requirements

- Computer with Microsoft Windows® 8, 7, Vista®, or XP (for CD-ROM Setup Wizard), Mac OS or Linux
- PC with 1.3GHz or above; at least 128MB RAM
- Internet Explorer 7 or above , Firefox 3.5 or above, Safari 4 and Chrome 8.0 or above
- Existing 10/100 Ethernet-based network
- A Micro SD memory card (optional) is required for recording to onboard storage. SDHC Class 6 or above is recommended.
- Broadband Internet connection

## Features

### **Wide Dynamic Range**

Wide Dynamic Range technology corrects imperfect lighting conditions, providing clear images with the right amount of contrast even when a subject is backlit

### **Remote Monitoring Utility**

The D-ViewCam application adds enhanced features and functionality for the Network Camera and allows administrators to configure and access the Network Camera from a remote site via Intranet or Internet. Other features include image monitoring, recording images to a hard drive, viewing up to 32 cameras on one screen, and taking snapshots.

### **IR LED for Day and Night Functionality**

The built-in infrared LEDs enables night time viewing of up to 15 meters (49 feet).

### **IP68 Weatherproof Housing**

The DCS-6314 uses an IP68 weatherproof housing, allowing you to rest assured that in the toughest of conditions, it will continue to provide round-the-clock surveillance.

### **PoE (Power over Ethernet) for Flexible Installation**

The DCS-6314 can get all the power it needs from a PoE switch or PoE injector for a simple and clutter-free installation.

# Hardware Overview

## Front



1	<b>Light Sensor</b>	The light sensor measures the lighting conditions and switches between color and infrared accordingly
2	<b>Camera Lens</b>	Vari-focal lens to record video of the surrounding area
3	<b>IR LEDs</b>	Infrared LEDs illuminate the camera's field of view at night
4	<b>Power/Status LED</b>	Indicates the camera's current status

## Top

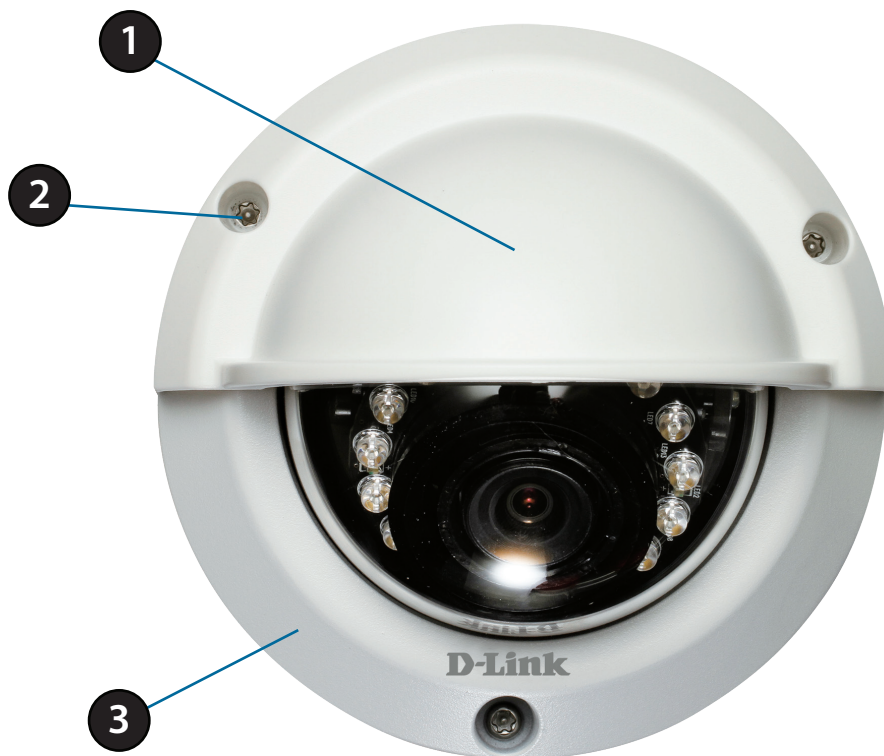

1	<b>Weather Shield</b>	Shields the camera sensor from direct sunlight.
2	<b>Adjustment Screw</b>	Used to secure the weather shield to the camera.
3	<b>Bottom Camera Shoe</b>	Used to attach to the optional mounting accessories.

**Note:** When the weathershield is attached, the camera video may show reflections when the IR LEDs are on and the camera is at a high angle. If you experience this, it is recommended that you lower the angle of the camera or turn off the IR LEDs. For details on how to adjust the camera angle, please see "Orienting the Camera" on page 22. For details on how to turn the IR LEDs on/off, please see "ICR and IR" on page 61.



## Cable Harness

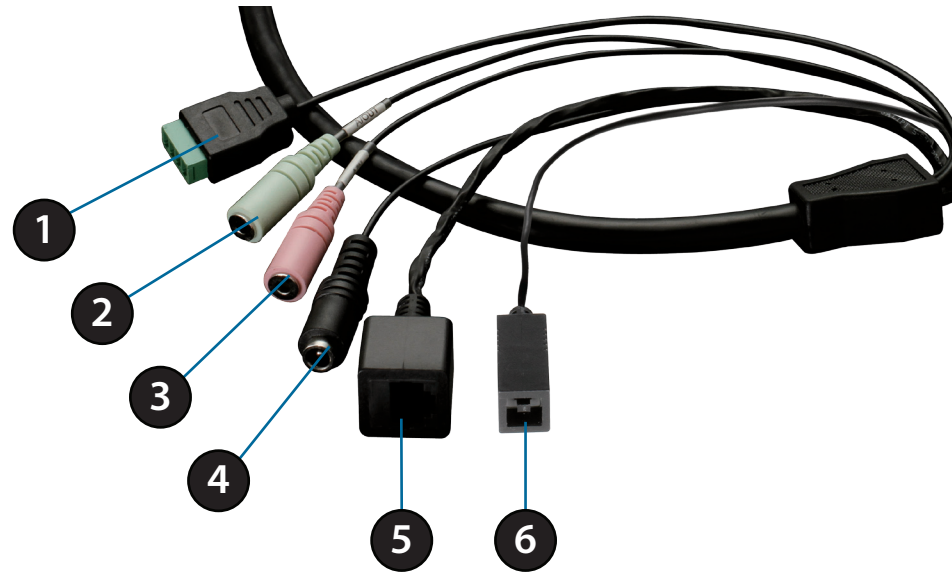

1	<b>DI/DO Connector</b>	I/O connectors for external devices. 12V DC output.
2	<b>Audio Out (Green)</b>	Connects to a speaker.
3	<b>Audio In (Red)</b>	Connects to a microphone.
4	<b>Power Connector</b>	Power connector for the provided 12V DC power adapter.
5	<b>Ethernet Jack</b>	Connects to an RJ45 Ethernet port. Can be used with PoE to provide power to the camera.
6	<b>Reset Button</b>	Press and hold the recessed button for 10 seconds to reset the camera.

## Internal

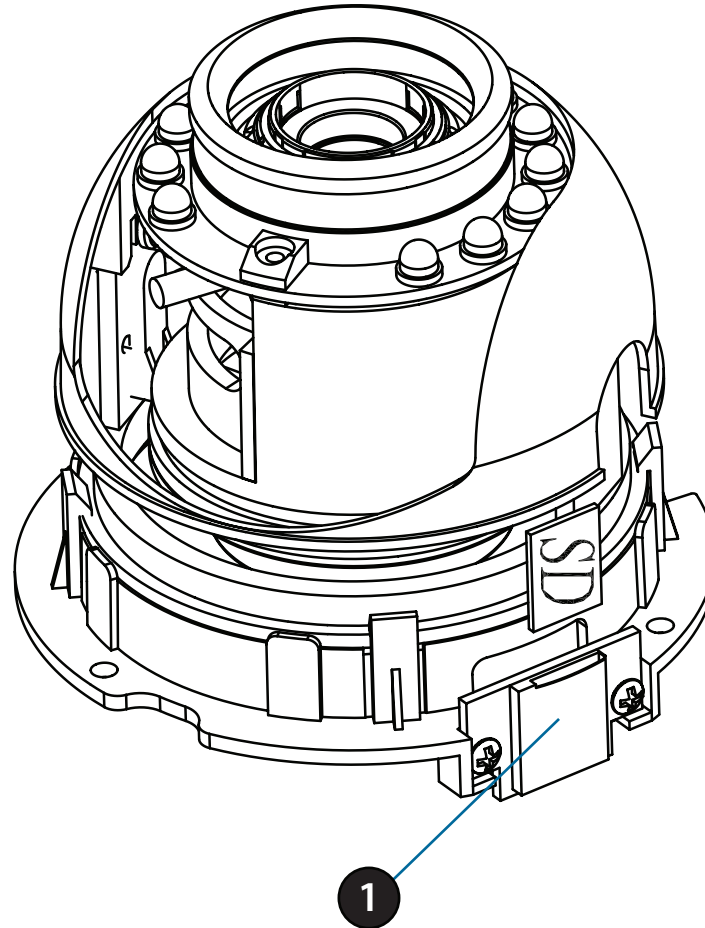

1	<b>Micro SD Card Slot</b>	Insert a Micro SD card for Local storage for storing recorded image and video
---	---------------------------	---

**Note:** For step-by-step instruction on how to insert a Micro SD card please skip to "Installing a Micro SD Card" on page 11.

# Assembly and Installation

## Installing a Micro SD Card

### Step 1

Place the camera face down on a non-slip flat surface.

### Step 2

Remove the adjustable top part of the camera housing by removing the three retaining screws.

### Step 3

Remove the base of the camera by holding the camera firmly and rotating the base in a counter clockwise direction.

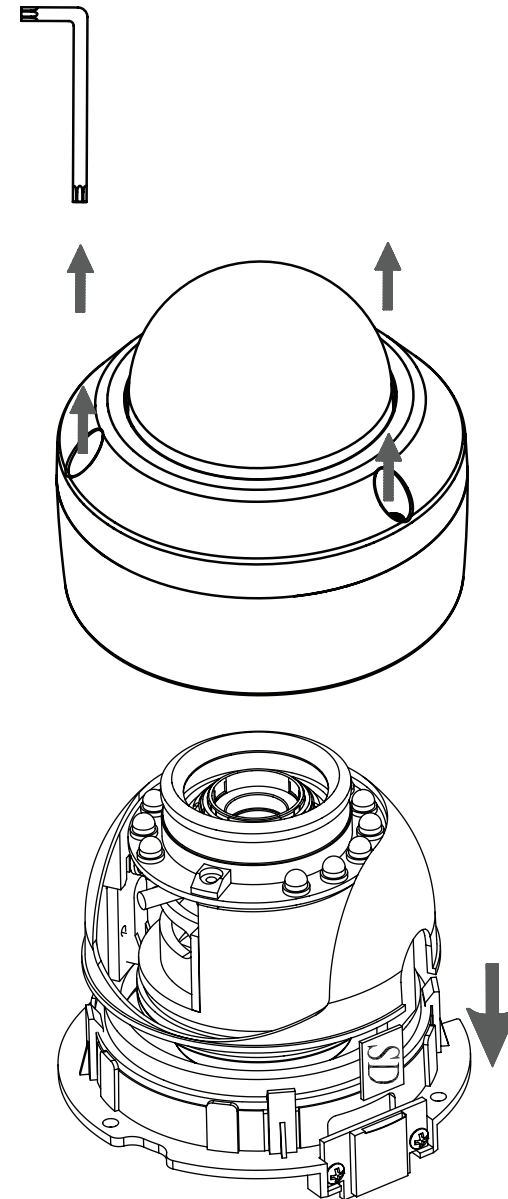

### Step 4

Insert your Micro SD memory card into the slot with the notch oriented to the front of the camera.

### Step 5

Replace the base of the camera by holding the camera firmly and rotating the base in a clockwise direction ensuring a tight fit.

**Note:** Users are advised to ensure that the weatherproof seals are secured firmly in place.

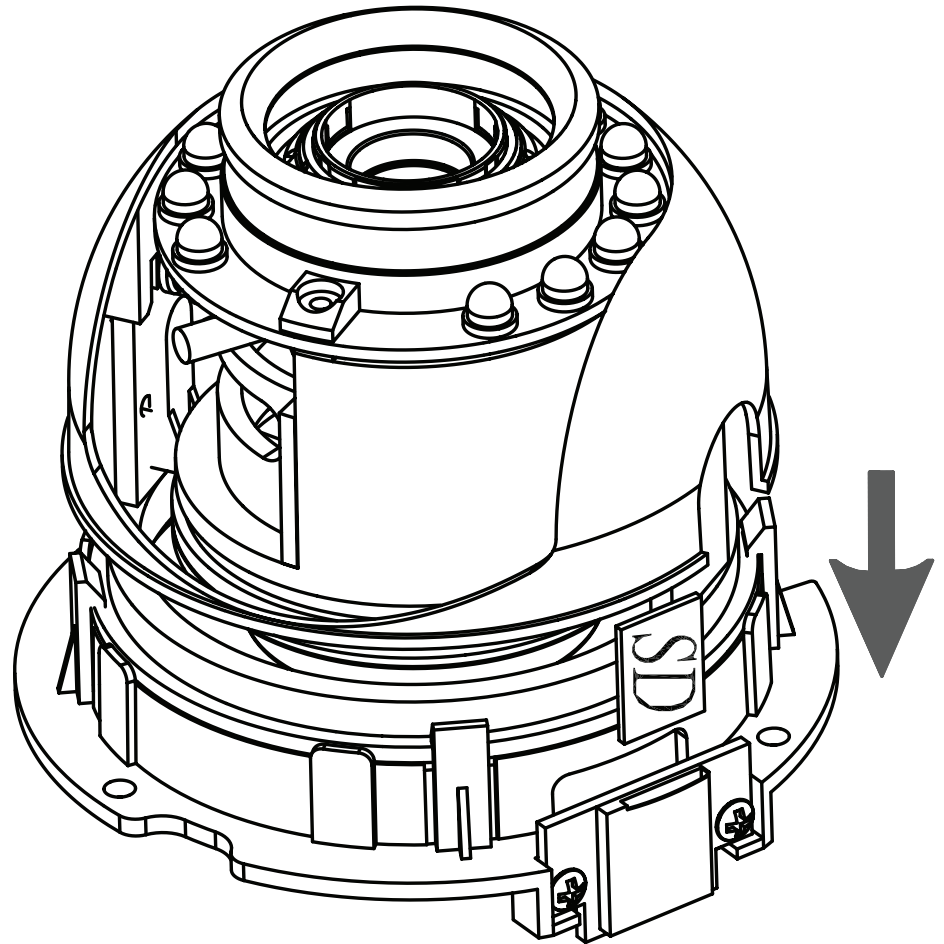

## Deploying the Camera

**Note:** Before deploying the camera to a fixed location, it is recommended that you take a photo from the desired location to ensure an adequate field-of-view.

### Step 1

Position the Alignment Sticker in the desired location making sure the Camera and Wire-in-Bracket have sufficient space. Use the dimension diagrams in "Dimensions" on page 73 for additional reference.

### Step 2

Use a 6mm drill bit to make required holes approximately 30mm deep.

### Step 3

Remove the Alignment Sticker.

### Step 4

Insert wall anchors and affix the mounting plate using the screws provided.

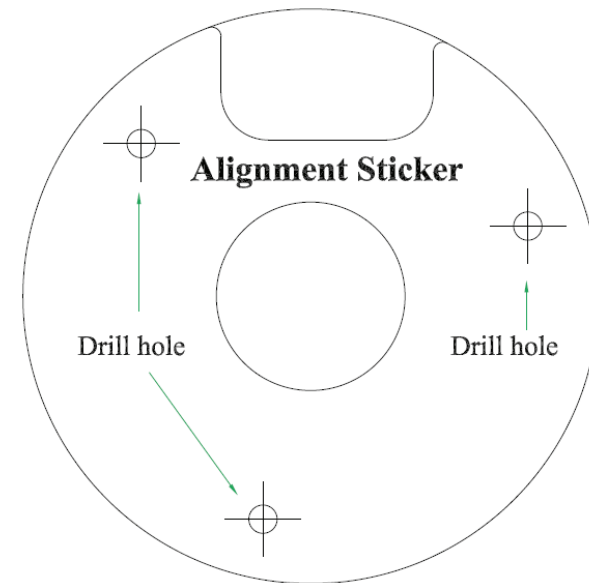

**Step 5**

Fasten the camera firmly to the mounting plate using the screw provided ensuring clear passage for the cables through the cable channel or via the mounting plate cut-out.

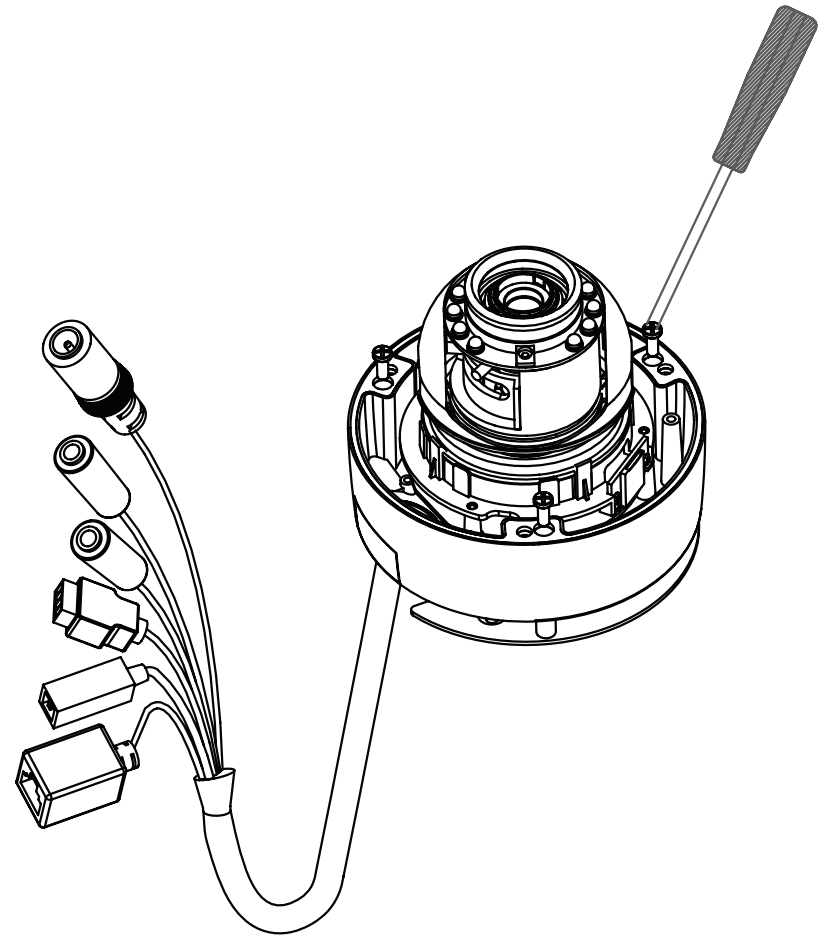

## Mounting the Camera

The DCS-6314 is suitable for mounting to a wall using the camera shoe and wire-in bracket provided.

### Step 1

Remove the top part of the camera housing by using the included tool to unscrew the three retaining screws.

### Step 2

Once the cover has been removed, use a screwdriver to remove the bottom mounting plate from the lower half of the camera housing. The mounting plate is secured with three screws positioned around the outer edge of the lower part of the camera housing.

If you will be mounting the camera directly to a wall or ceiling, please continue to the next page.

If you will be mounting the camera using the pendant mount, please refer to "Attaching the Camera to the Pendant Mount" on page 18.

If you will be mounting the camera using the bent mount, please refer to "Attaching the Camera to the Bent Mount" on page 20.

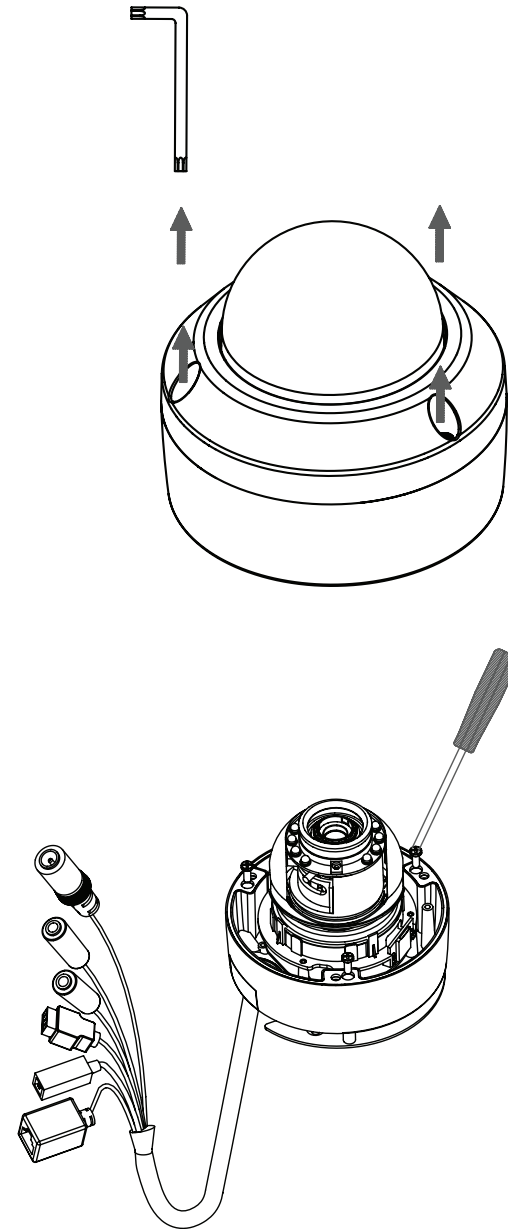

### Step 3

Remove the mounting plate from the lower half of the camera housing. It can now be attached to a wall or ceiling using the mounting guide. Please see "Deploying the Camera" on page 13 for more instructions.

If you will be installing the camera onto a surface that cannot house the cable, the cable access part can be removed so that the cable can exit the camera housing easily. Once the mounting plate has been removed, you will be able to remove the cable access panel. If you will be routing the connection cables through a wall or ceiling, it is recommended to leave this part attached, as it will help protect the cable from vandalism.

### Step 4

Slide the lower half of the camera housing onto the mounting plate and resecure it. Make sure that the cable sheath extends out of the base in such a way that the cable is not kinked or twisted.

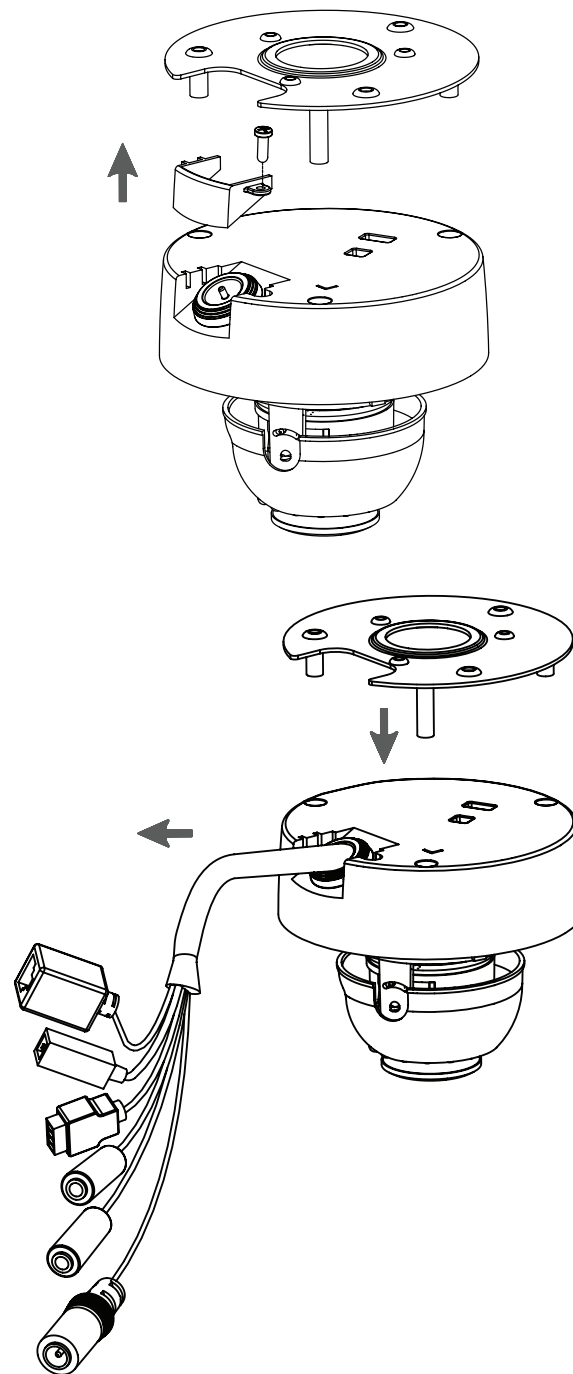



**Step 5**

Reattach the top part of the camera housing, and secure it by tightening the three retaining screws.

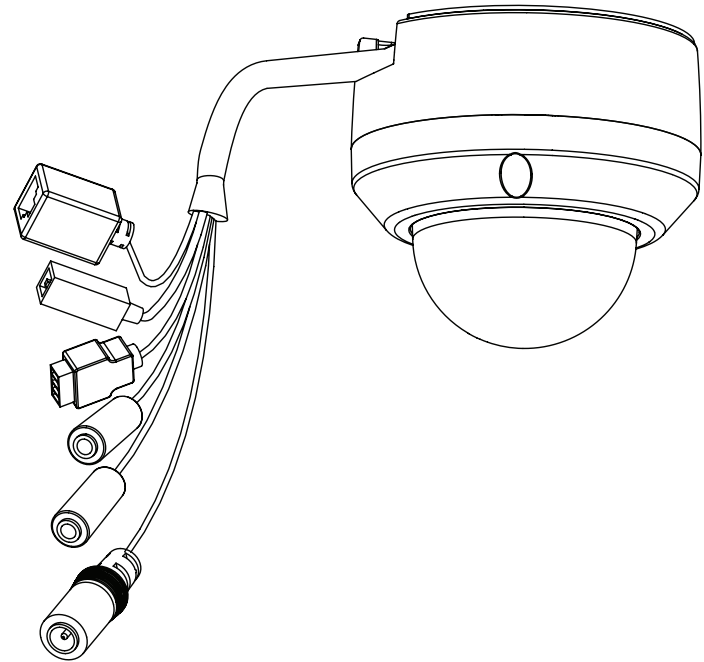

**Step 6**

If necessary, the included weather shield can now be attached to the camera.

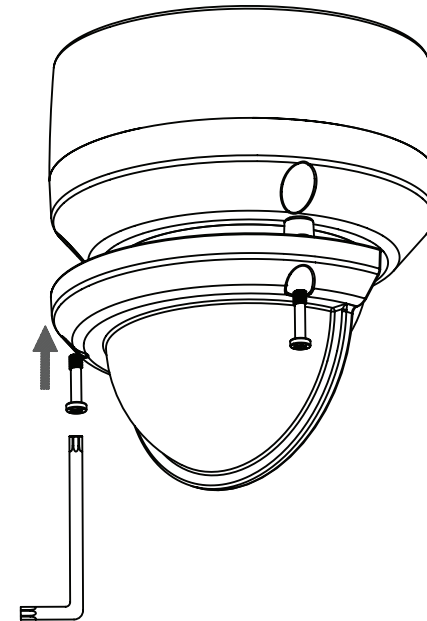

## Attaching the Camera to the Pendant Mount

### Step 1

Begin by attaching the mounting plate that was removed from the lower part of the camera housing into the bracket cap.

### Step 2

Place the rubber seal onto the mounting part of the pendant bracket. Use the included mounting guide to mark out on the ceiling the proper placement of the mounting holes. Securely mount the rubber seal and pendant bracket to the ceiling, if you need more details please see "Deploying the Camera" on page 13.

### Step 3

Attach the bracket cap, by screwing it onto the pendant bracket.

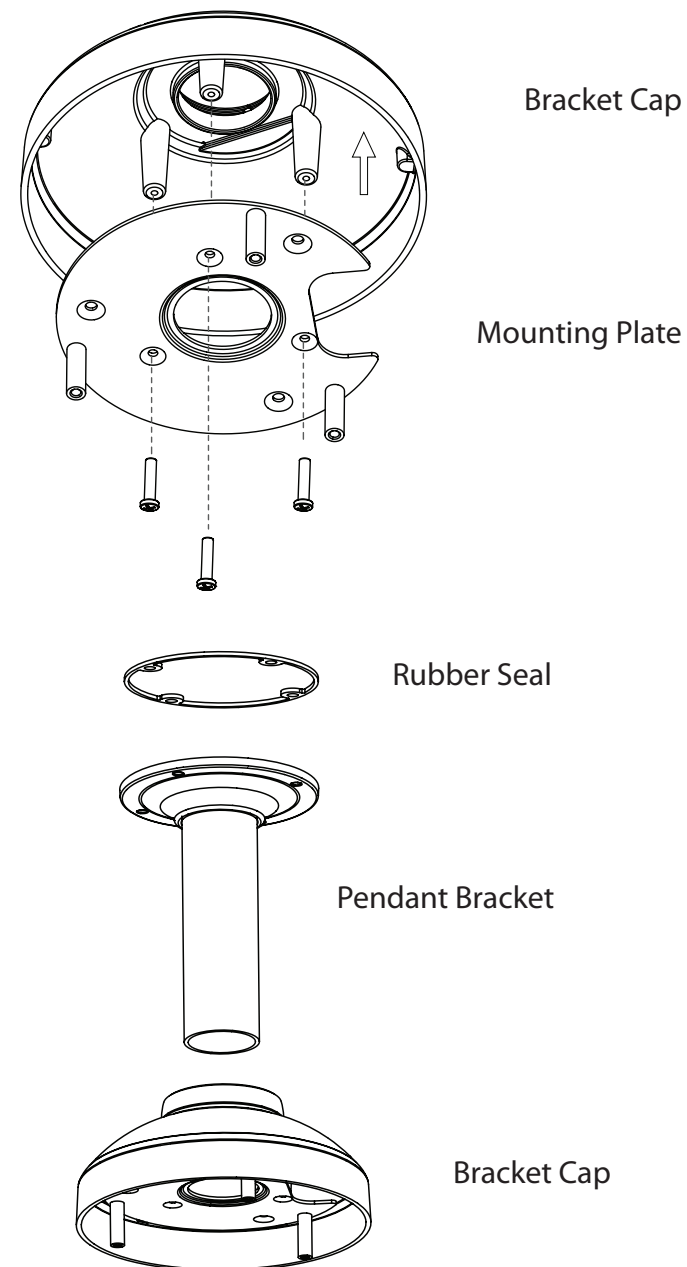

### Step 4

Begin the process of reattaching the bottom part of the camera housing, by first pushing the cable sheath up through the pendant mount. Once the cable has been pushed through, you can then firmly reattach the bottom part of the camera housing, and secure it by tightening the three retaining screws.

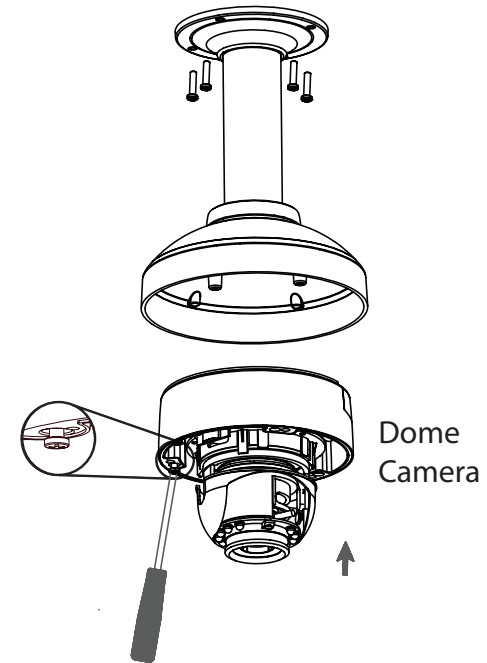

### Step 5

Reattach the top part of the camera housing, and secure it by tightening the three retaining screws.

If necessary, the included weather shield can now be attached to the camera. Please see step 6 of "Mounting the Camera" on page 15 for more details on how to do this.

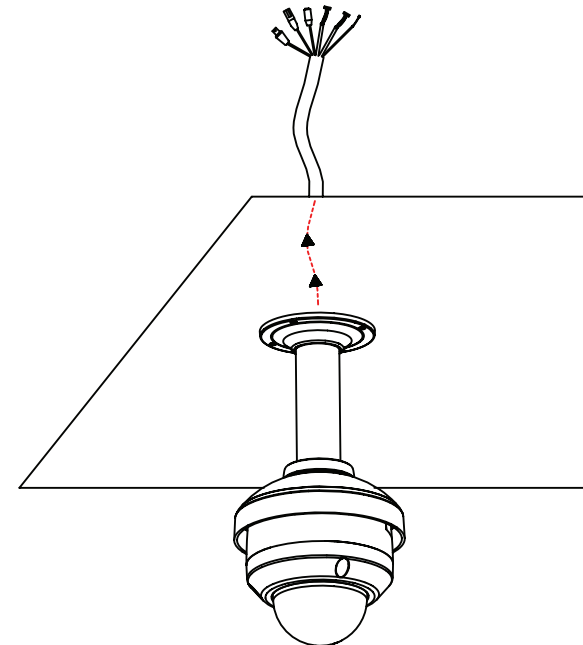

## Attaching the Camera to the Bent Mount

### Step 1

Begin by attaching the mounting plate that was removed from the lower part of the camera housing into the bracket cap.

### Step 2

Place the rubber seal onto the mounting part of the bent bracket. Use the included mounting guide to mark out on the ceiling the proper placement of the mounting holes. Securely mount the rubber seal and pendant bracket to the ceiling, if you need more details please see "Deploying the Camera" on page 13.

### Step 3

Attach the bracket cap, by screwing it onto the pendant bracket.

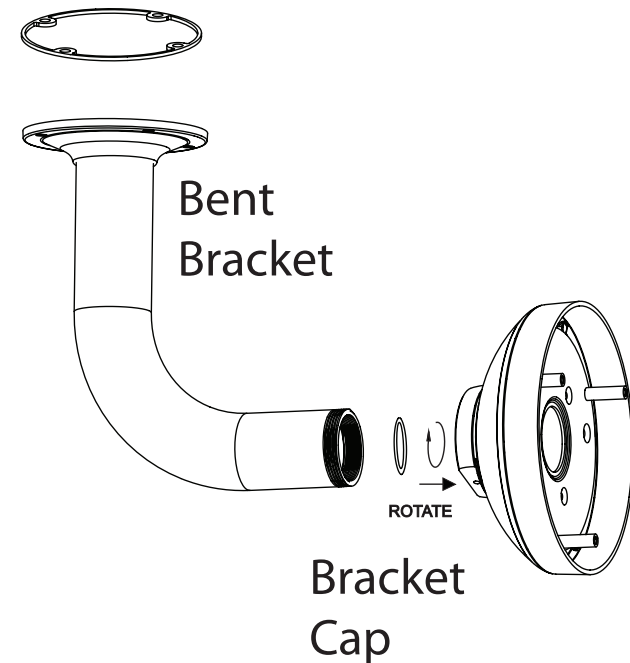
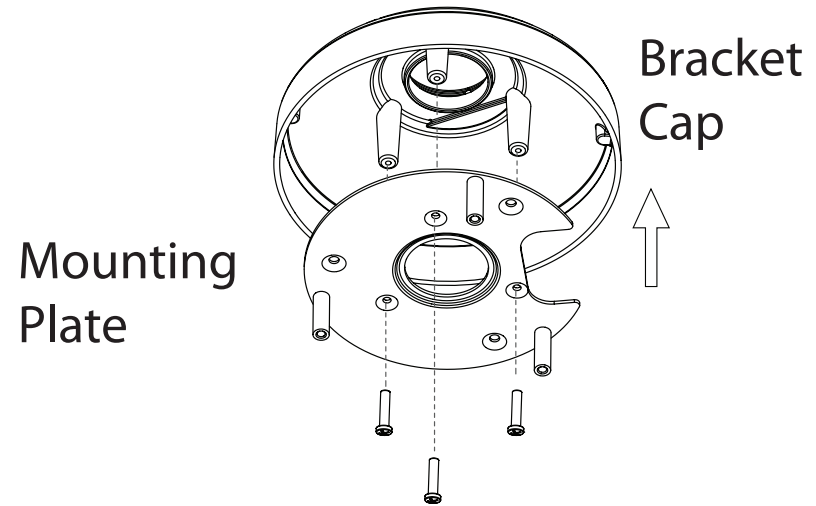

### Step 4

Begin the process of reattaching the bottom part of the camera housing, by first pushing the cable sheath up through the bent mount. Once the cable has been pushed through, you can then firmly reattach the bottom part of the camera housing, and secure it by tightening the three retaining screws.

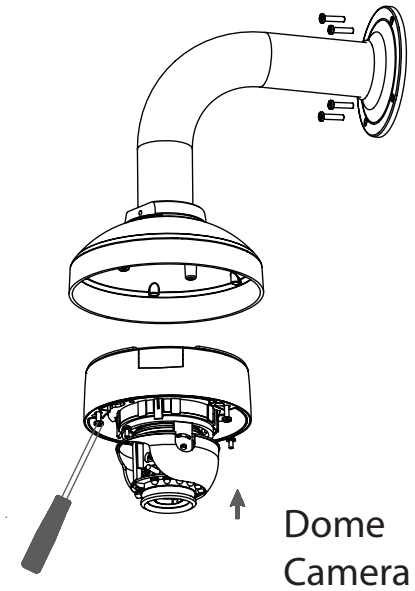

### Step 5

Reattach the top part of the camera housing, and secure it by tightening the three retaining screws.

If necessary, the included weather shield can now be attached to the camera. Please see step 6 of "Mounting the Camera" on page 15 for more details on how to do this.

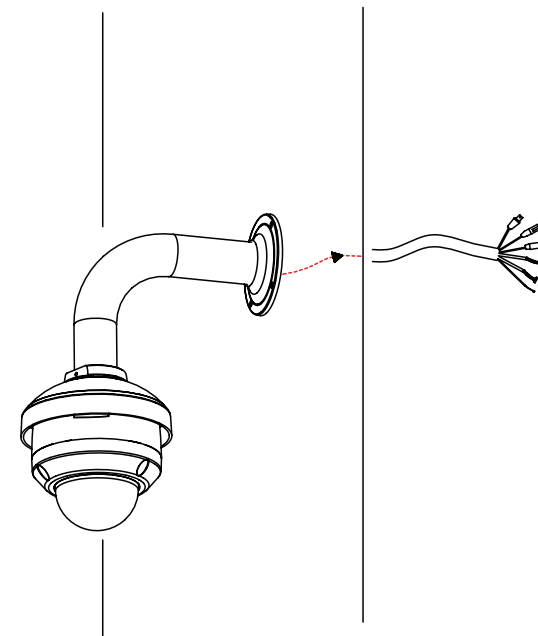

## Orienting the Camera

The DCS-6314 can be adjusted to ensure an optimal viewing position when mounted to a wall by following the steps outlined.

### Step 1

Turn the lens module left and right until the desired position is achieved.

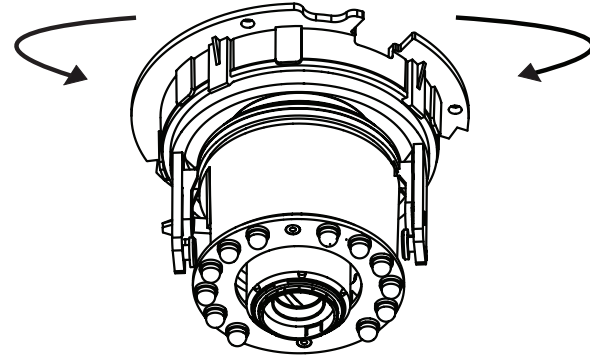

### Step 2

Loosen the tilt screws on both sides of the camera, and turn the lens module up and down until the desired position is achieved.

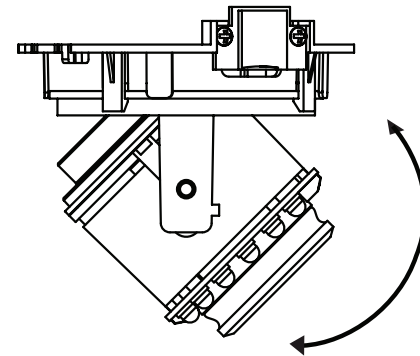

### Step 3

Turn the lens to adjust the IP camera's image until the desired orientation is achieved.

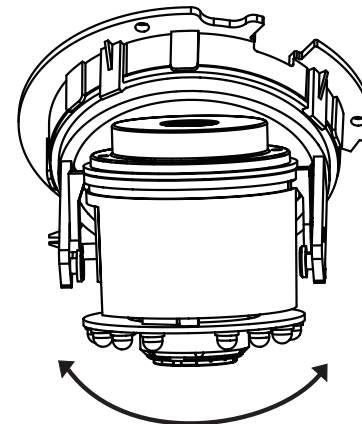

# Camera Installation Wizard

## General Connection Using 12 V DC Power Adapter

### Step 1

Connect the network camera to a hub via an Ethernet cable.

### Step 2

Connect the supplied power cable from the camera to a power outlet.

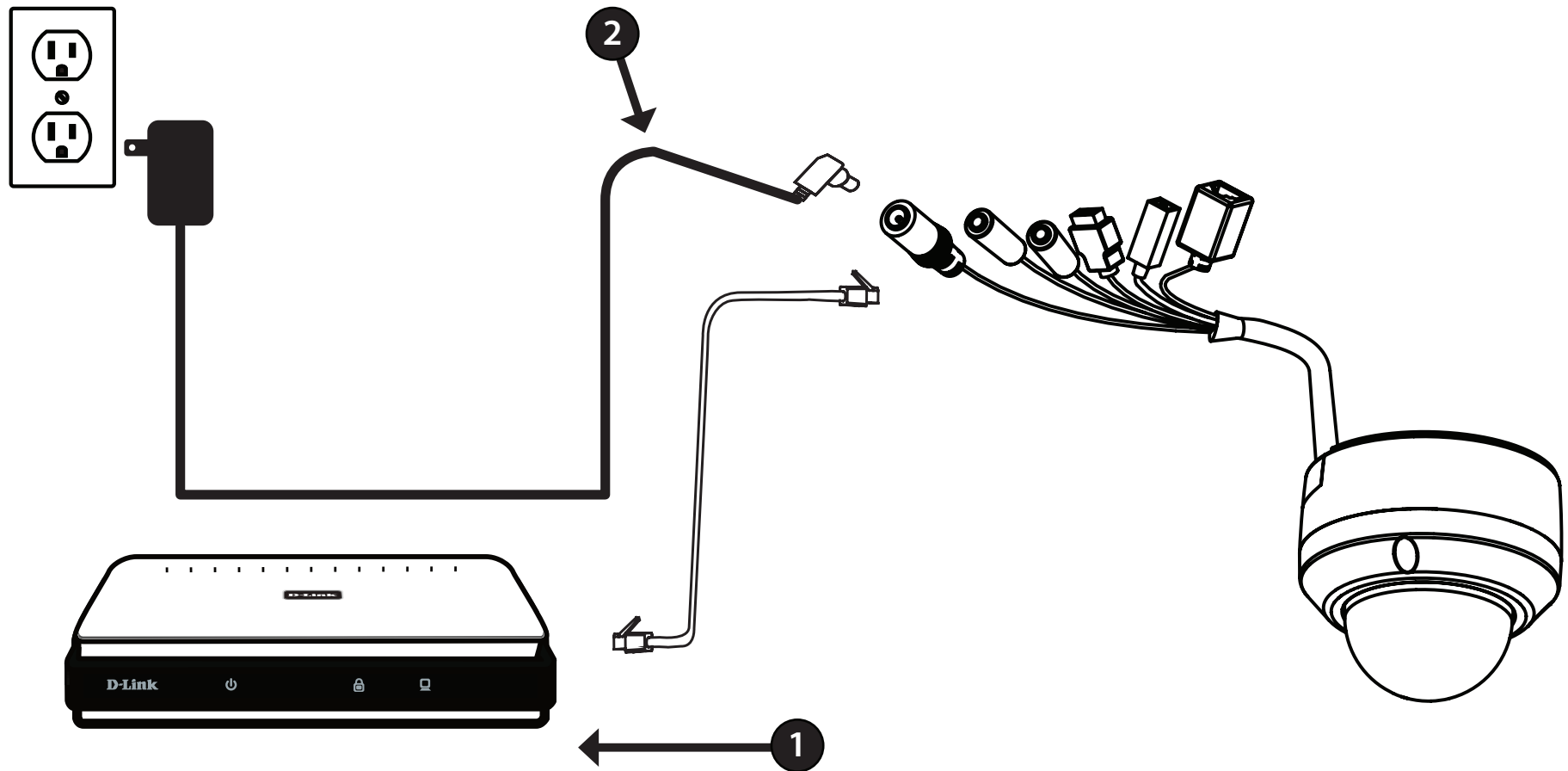

## Connection Using Power over Ethernet

**Step 1**  
If you are using a PoE hub, connect the IP camera to the hub via an Ethernet cable, which will provide transmission of both power and data over a single cable.

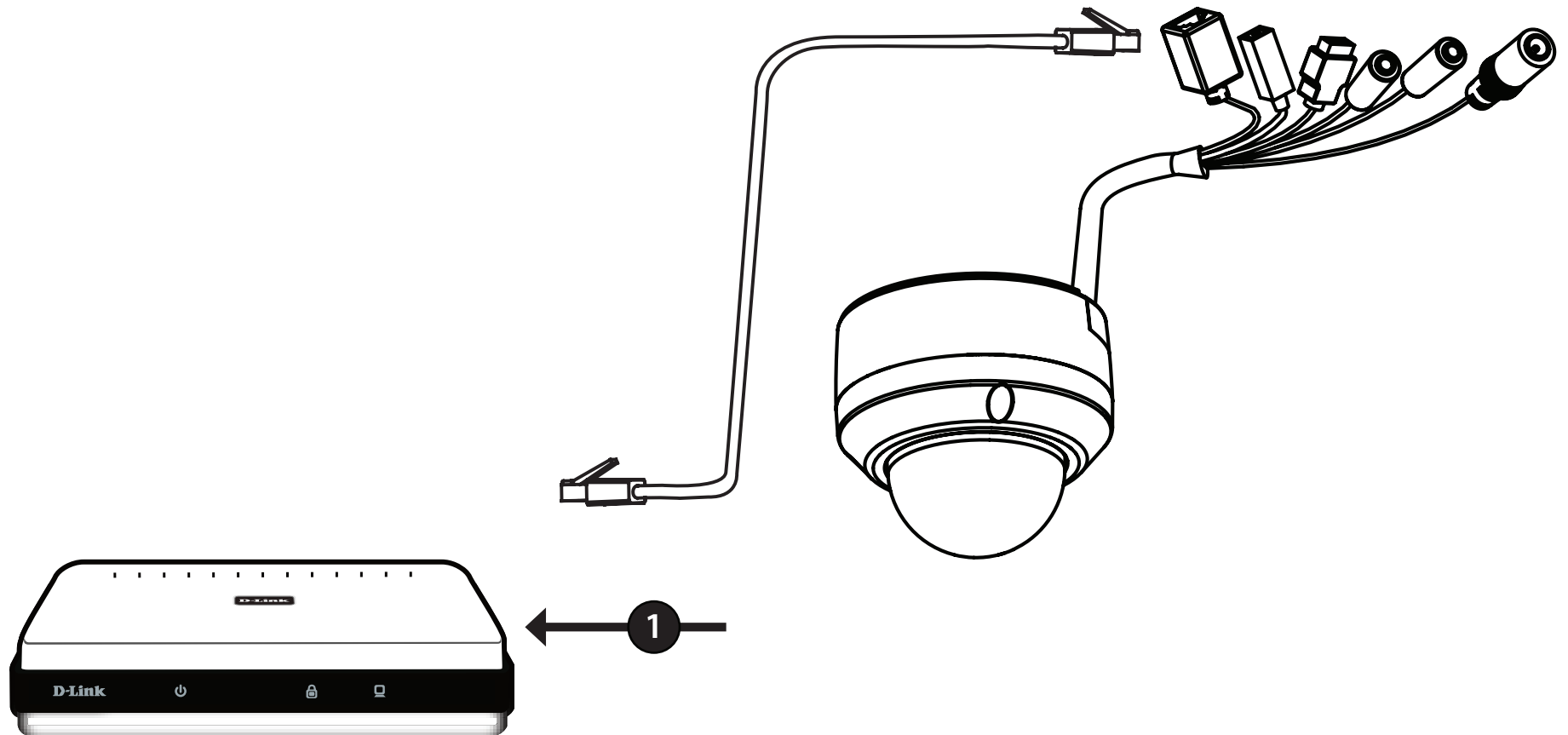



## Software Installation

### Step 1

Insert the Installation CD-ROM into your computer's optical drive to start the autorun program.

The CD-ROM will open the Camera Installation Wizard. The Setup Wizard will guide you through the installation process through to configuring your camera.

### Note:

If the autorun program does not automatically start on your computer, go to Windows, click **Start > Run**. In the Run command box type **D:\setup.exe**, where D: represents your CD-ROM drive.

### Step 2

Accept the End User Licence Agreement and follow the on screen prompts to install the Camera Installation Wizard.

### Step 3

Select your camera from the list, then click **Wizard**. If you have multiple cameras, you can identify them by the MAC ID printed on the label on the back of your camera.



### Step 4

By default the **Admin ID** is "admin" and the password is blank.

It is recommended that you create and confirm a password for your device.

Click **Next** to continue.

The screenshot shows the 'Set up an Admin ID and Password to secure your camera.' screen. At the top, there is a D-Link logo and the 'SECURICAM Network' header. The main heading reads 'Set up an Admin ID and Password to secure your camera. Click Next to continue.' Below this, there are two columns of input fields. The first column has 'Admin ID' and 'Password' fields. The second column has 'New ID', 'New Password', and 'Reconfirm' fields. Each of these second-column fields is preceded by a 'Change' checkbox. At the bottom right, there are three buttons: 'Back' (left arrow), 'Next' (right arrow), and 'Exit' (stop sign).

### Step 5

Select **Static IP** if your Internet Service Provider has provided you with connection settings, or if you wish to set a static address within your home network. Enter the correct configuration information and click **Next** to continue.

**Note:** Select DHCP if you are unsure of which settings to choose.

Click **Next** to continue.

The screenshot shows the 'Set IP Address' screen. At the top, there is a D-Link logo and the 'SECURICAM Network' header. The main heading reads 'Set IP Address'. Below this, there are two radio button options: 'DHCP' (which is selected) and 'Static IP'. Under the 'Static IP' option, there are five input fields: 'IP Address', 'Subnet Mask', 'Default Gateway', 'Primary DNS', and 'Secondary DNS'. At the bottom right, there are three buttons: 'Back' (left arrow), 'Next' (right arrow), and 'Exit' (stop sign).

**Step 6**

Confirm your camera login details and IP address details and click **Restart**.

The LED on the front of the DCS-6314 will blink, then turn solid green once it successfully connects to your network..

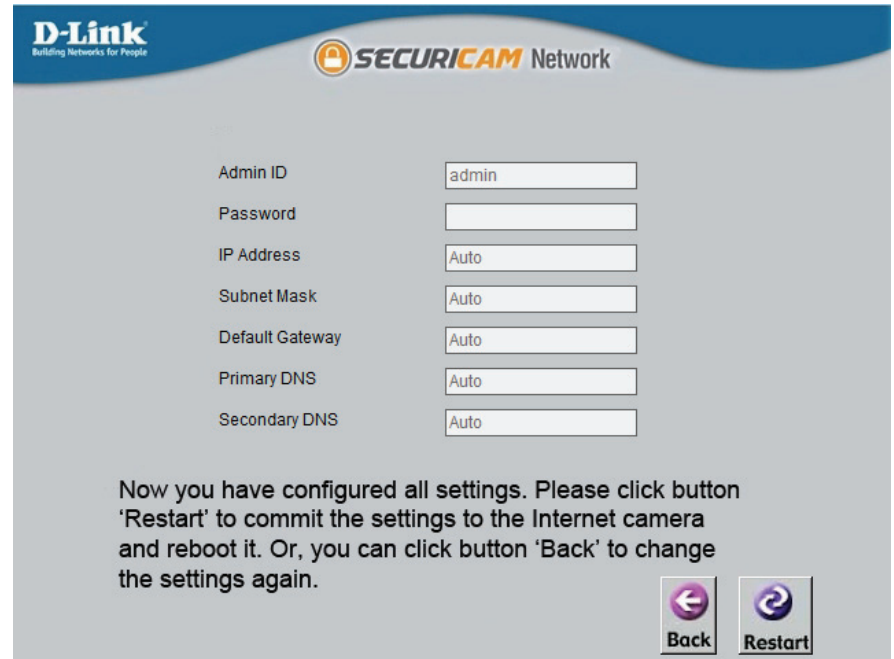

**Step 7**

Your DCS-6314 camera is now set up, Click **Exit** to exit the wizard and can skip to "Configuration" on page 30 for advanced configuration of your camera.

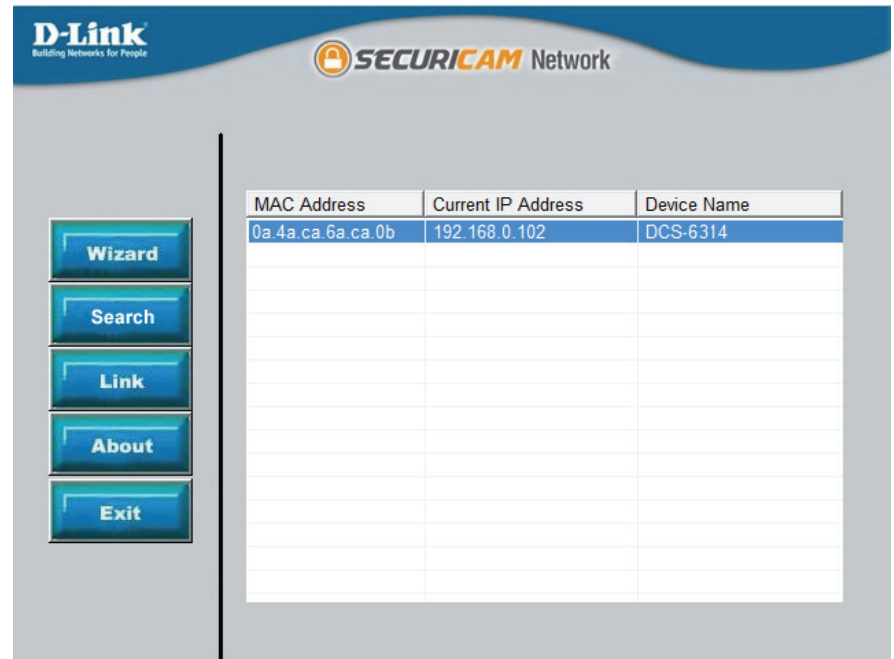

## D-ViewCam Setup Wizard

D-ViewCam software is included for the administrator to manage multiple D-Link IP cameras remotely. You may use the software to configure all the advanced settings for your cameras. D-ViewCam is a comprehensive management tool for IP surveillance.

### Step 1

Insert the CD-ROM into the CD-ROM drive. Click "Install D-ViewCam Software" from menu, and select "D-ViewCam" to install the VMS software.

### Step 2

Follow the Installation Wizard to install D-ViewCam.

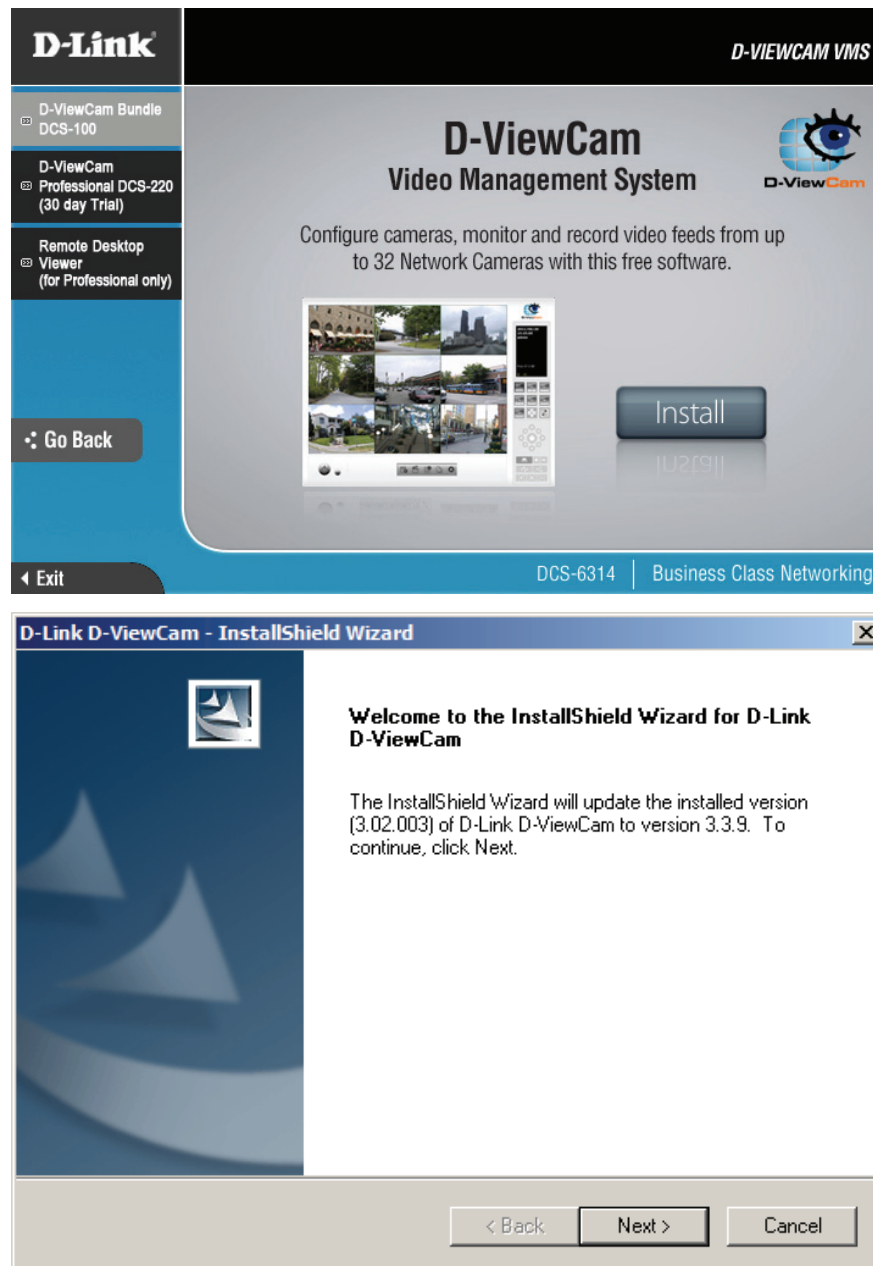

### Step 3

Click **Finish** to complete the installation.

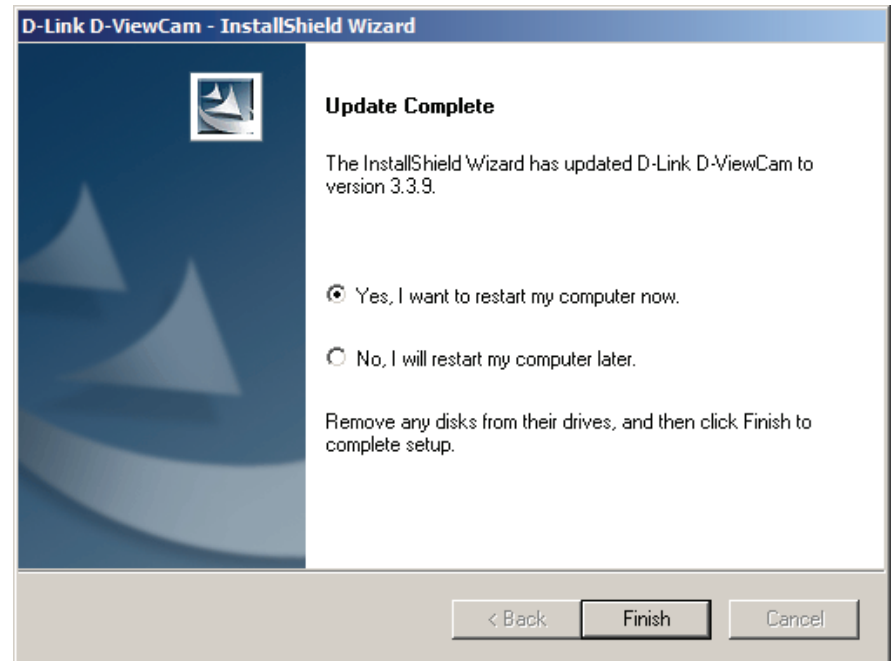

### Step 5

For more detail operation of using the D-ViewCam software, please refer to D-ViewCam Manual.

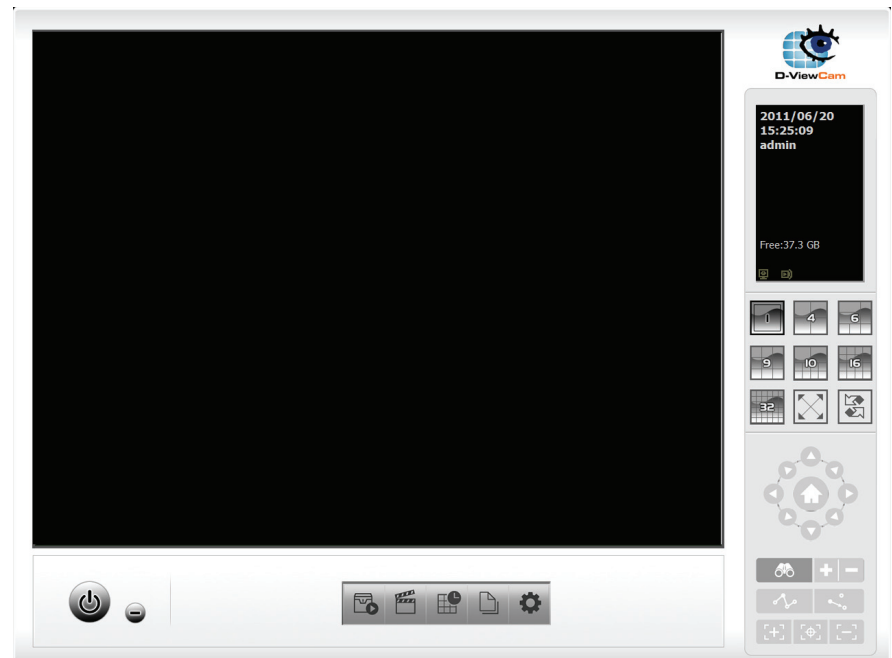

# Configuration

## Using the Configuration Interface

After completing the Camera Installation Wizard, you are ready to use your camera. The camera's built-in Web configuration utility is designed to allow you to easily access and configure your DCS-6314. At the end of the wizard, click **Link**, or enter the IP address of your camera into a web browser, such as Mozilla Firefox. To log in, use the User name **admin** and the password you created in the Installation Wizard. If you did not create a password, the default password is blank. After entering your password, click **OK**.

### Step 1

Click the **Link** button on the Wizard. The Setup Wizard will automatically open your web browser to the IP address of the camera.

### Step 2

Enter your credentials to access the configuration interface.



## Live Video

This section shows your camera's live video. You may select any of the available icons listed below to operate the camera. You may also select your language using the drop-down menu on the left side of the screen.

You can zoom in and out on the live video image using your mouse. Right-click to zoom out or left-click to zoom in on the image.

**SD Status:** This option displays the status of the SD card. If no SD card has been inserted, this screen will display the message "Card Invalid."

**IO Status:** This option displays the status of your I/O device if a device has been connected.

**ePTZ Speed:** You may select a value between 0 and 10. 0 is the slowest and 10 is the fastest.







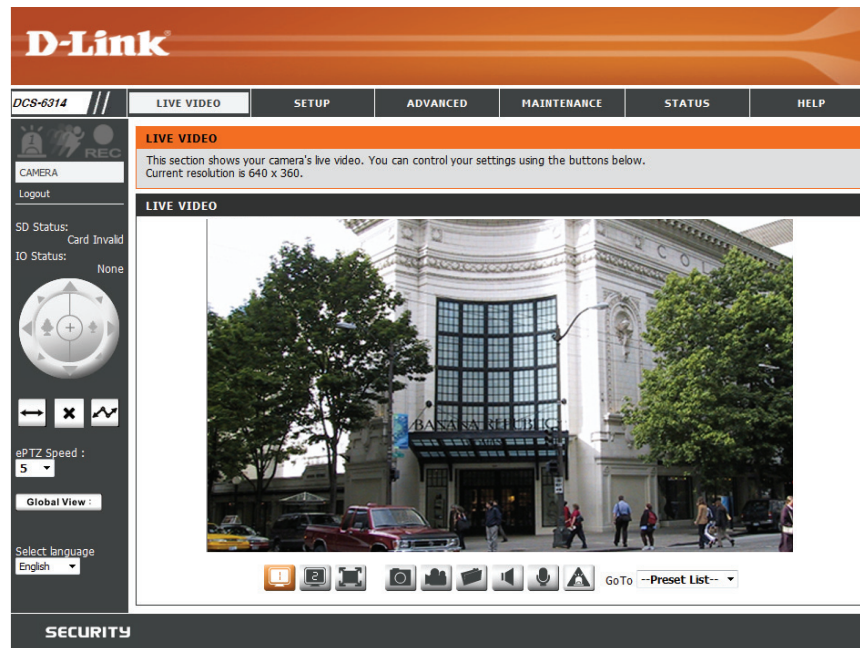









**Global View:** This window indicates the total field of view (FOV) of the camera. The red box indicates the visible region of interest (ROI). This option will only be present if the view window size is set to be smaller than the current frame size. You can find more information on how to set the frame size and view window area in "Audio and Video" on page 45.

**Language:** You may select the interface language using this menu.

**Go To:** If any presets have been defined, selecting a preset (**Preset List**) from this list will display it.



## Section 3: Configuration

	<b>Digital Input Indicator</b>	This indicator will change color when a digital input signal is detected.
	<b>Motion Trigger Indicator</b>	This indicator will change color when a trigger event occurs. <b>Note:</b> The video motion feature must be enabled.
	<b>Recording Indicator</b>	When a recording is in progress, this indicator will change color.
	<b>Control Pad</b>	This control pad can be used to electronically pan, tilt, and zoom (ePTZ) within the camera's predefined view area, if one has been defined.
	<b>Auto Pan</b>	Starts the automatic panning function. The ROI will pan from back and forth within the FOV
	<b>Stop</b>	Stops the camera ePTZ motion
	<b>Preset Path</b>	Starts the camera's motion along the predefined path
	<b>Video Profile 1</b>	Select's predefined settings configured on page 45
	<b>Video Profile 2</b>	Select's alternate predefined settings configured on page 45
	<b>Full Screen Mode</b>	Will enlarge the video stream to use fullscreen
	<b>Take a Snapshot</b>	Will record the current image
	<b>Record Video Clip</b>	Will record a video clip, using predefined settings
	<b>Set up Storage</b>	Will allow you to select a folder on your computer to save to.
	<b>Listen/Stop Listening</b>	Enable or disable the ability to listen through the built in microphone.
	<b>Talk/Stop Talking</b>	Enable or disable the ability to speak through the built in speaker.
	<b>Start/Stop Digital Output</b>	Enable or disable the ability to use the built in digital in/out port.

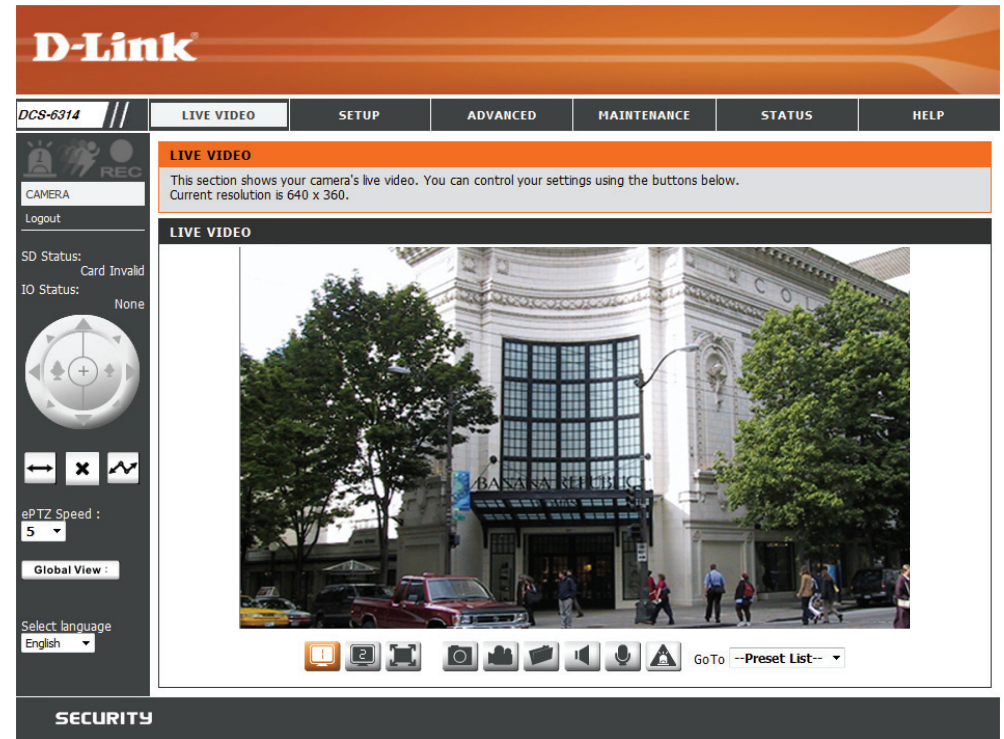

**D-Link**

DCS-6314 // LIVE VIDEO SETUP ADVANCED MAINTENANCE STATUS HELP

**LIVE VIDEO**

This section shows your camera's live video. You can control your settings using the buttons below. Current resolution is 640 x 360.

**LIVE VIDEO**

CAMERA  
Logout

SD Status: Card Invalid  
IO Status: None

ePTZ Speed: 5

Global View

Select language: English

GoTo --Preset List--

**SECURITY**



# Setup Setup Wizard

To configure your Network Camera, click **Internet Connection Setup Wizard**. Alternatively, you may click **Manual Internet Connection Setup** to manually configure your Network Camera and skip to "Network Setup" on page 39.

To quickly configure your Network Camera's motion detection settings, click **Motion Detection Setup Wizard**. If you want to enter your settings without running the wizard, click **Manual Motion Detection Setup** and skip to "Motion Detection" on page 49.

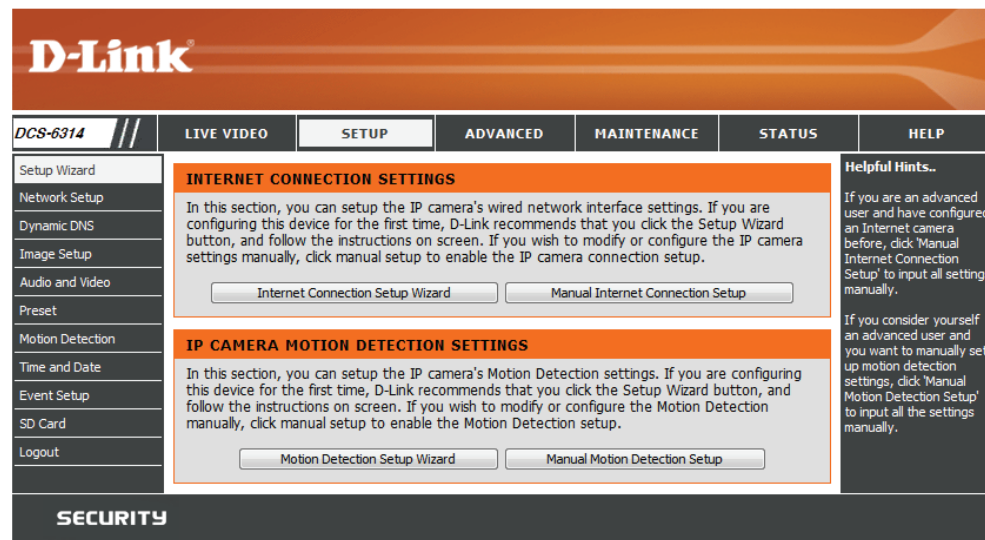

## Internet Connection Setup Wizard

This wizard will guide you through a step-by-step process to configure your new D-Link Camera and connect the camera to the internet. Click **Next** to continue.

**Note:** Select DHCP if you are unsure of which settings to choose.

Select **Static IP** if your Internet Service Provider has provided you with connection settings, or if you wish to set a static address within your home network. Enter the correct configuration information and click **Next** to continue.

If you are using PPPoE, select **Enable PPPoE** and enter your user name and password, otherwise click **Next** to continue.

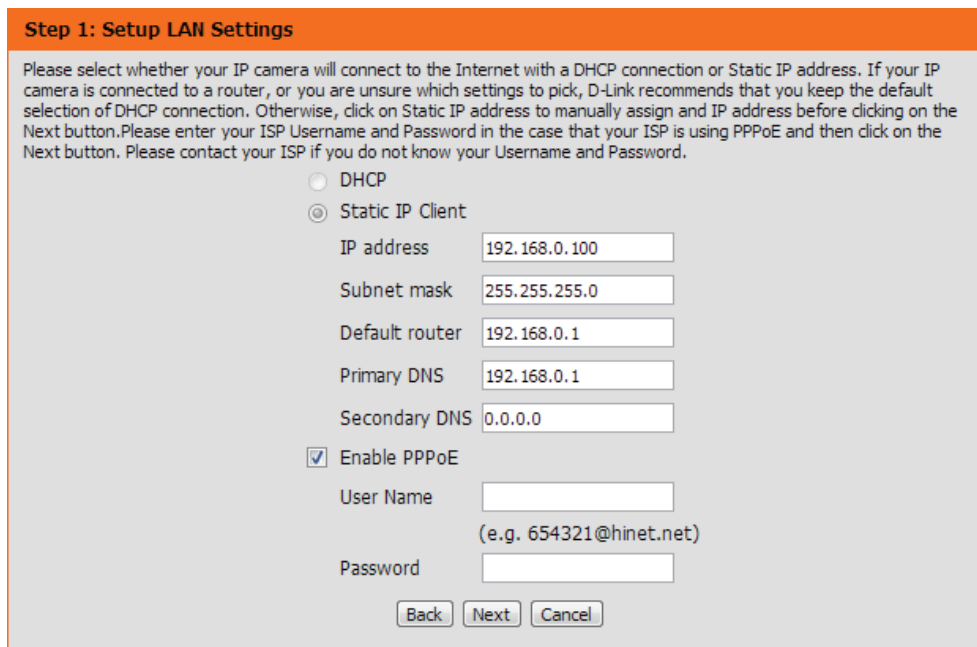
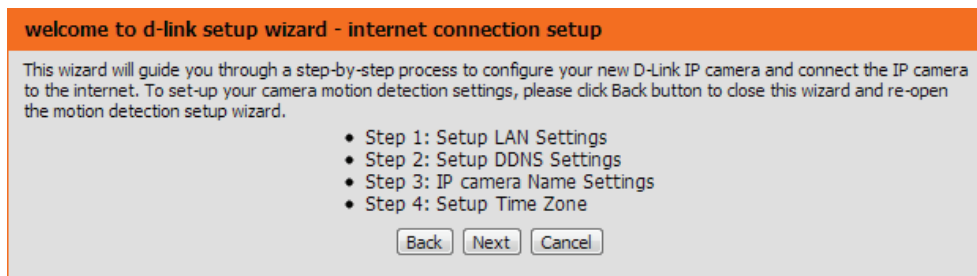

## Section 3: Configuration

If you have a Dynamic DNS account and would like the camera to update your IP address automatically, Select **Enable DDNS** and enter your host information. Click **Next** to continue.

**Step 2: Setup DDNS Settings**

If you have a Dynamic DNS account and would like the IP camera to update your IP address automatically, enable DDNS and enter in your host information below. Please click on the Next button to continue.

Enable DDNS

Server Address  <<  ▼

Host Name

User Name

Password

Verify Password

Timeout  (hours)

Enter a name for your camera and click **Next** to continue.

**Step 3: IP camera Name Settings**

D-Link recommends that you rename your IP camera for easy accessibility. You can then identify and connect to your IP camera via this name. Please assign a name of your choice before clicking on the Next button.

IP camera Name

## Section 3: Configuration

Configure the correct time to ensure that all events will be triggered as scheduled. Click **Next** to continue.

**Step 4: Setup Time Zone**

Please configure the correct time to ensure that all events are triggered, captured and scheduled at the correct time and day and then click on the Next button.

Time Zone

Enable Daylight Saving

Confirm the settings are correct and click **Apply** to save them.

The settings will be saved to the DCS-6314 and the camera will restart.

**Step 5: Setup complete**

Below is a summary of your IP camera settings. Click on the Back button to review or modify settings or click on the Apply button if all settings are correct. It is recommended to note down these settings in order to access your IP camera on the network or via your web browser.

IP Address	DHCP
IP camera Name	DCS-6314
Time Zone	(UTC+08:00) Taipei
DDNS	Disable
PPPoE	Disable

## Motion Detection Setup Wizard

This wizard will guide you through a step-by-step process to configure your camera's motion detection functions.

Click **Next** to continue.

### Step 1

This step will allow you to enable or disable motion detection, specify the detection sensitivity, and adjust the camera's ability to detect movement.

You may specify whether the camera should capture a snapshot or a video clip when motion is detected.

Please see the **Motion Detection** section on "Motion Detection" on page 49 for information about how to configure motion detection.

### Step 2

This step allows you to enable motion detection based on a customized schedule. Specify the day and hours. You may also choose to always record whenever motion is detected.

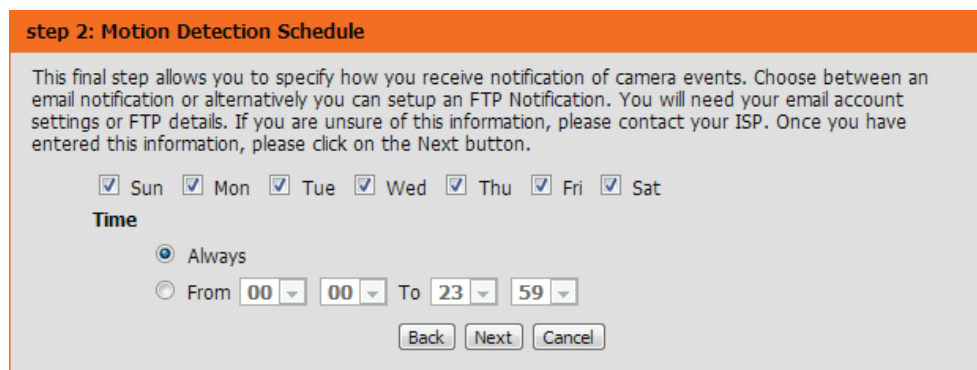
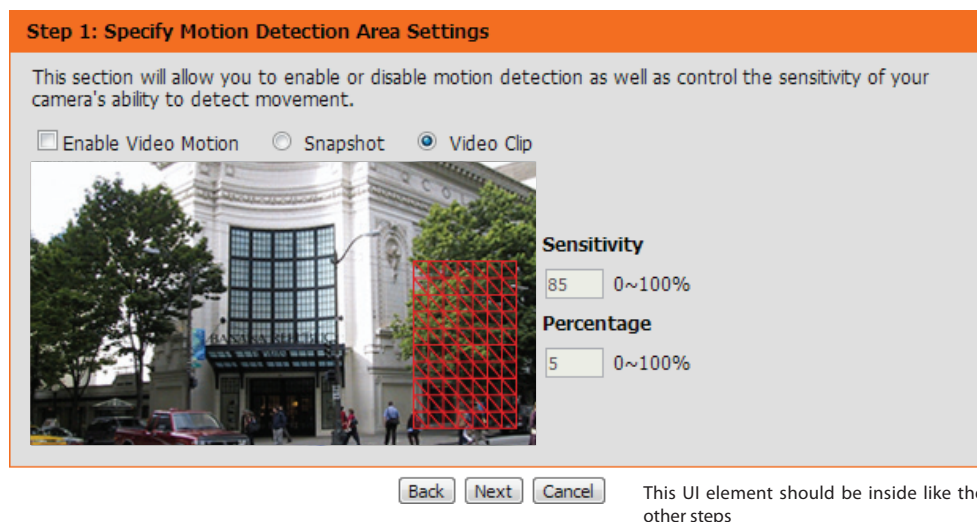
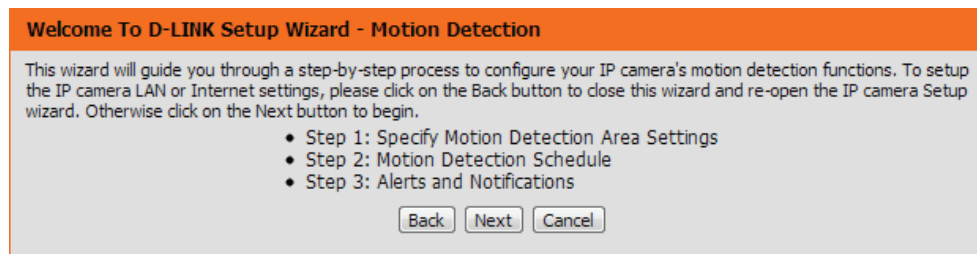

## Section 3: Configuration

### Step 3

This step allows you to specify how you will receive event notifications from your camera. You may choose not to receive notifications, or to receive notifications via e-mail or FTP.

Please enter the relevant information for your e-mail or FTP account.

Click **Next** to continue.

**Step 3: Alerts and Notification**

This final step allows you to specify how you receive notification of camera events. Choose between an email notification or alternatively you can setup an FTP Notification. You will need your email account settings or FTP details. If you are unsure of this information, please contact your ISP. Once you have entered this information, please click on the Next button.

Do not notify me

Email

Sender email address

Recipient email address

Server address

User name

Password

Port

FTP

Server address

Port

User name

Password

Remote folder name

### Step 4

You have completed the Motion Detection Wizard.

Please verify your settings and click **Apply** to save them.

Please wait a few moments while the camera saves your settings and restarts.

**Step 4: Setup Complete**

You have completed your IP camera setup. Please click the Back button if you want to review or modify your settings or click on the Apply button to save and apply your settings.

Motion Detection : Enable

EVENT : Video Clip

Schedule Day : Sun , Mon , Tue , Wed , Thu , Fri , Sat ,

Schedule Time : Always

Alerts and Notification : Do not notify me

## Network Setup

Use this section to configure the network connections for your camera. All relevant information must be entered accurately. After making any changes, click the **Save Settings** button to save your changes.

**LAN Settings:** This section lets you configure settings for your local area network.

**DHCP:** Select this connection if you have a DHCP server running on your network and would like your camera to obtain an IP address automatically.

**Static IP Client:** You may obtain a static or fixed IP address and other network information from your network administrator for your camera.

**IP Address:** Enter the fixed IP address in this field.

**Subnet Mask:** This number is used to determine if the destination is in the same subnet. The default value is 255.255.255.0.

**Default Gateway:** The gateway used to forward frames to destinations in a different subnet. Invalid gateway settings may cause the failure of transmissions to a different subnet.

**Primary DNS:** The primary domain name server translates names to IP addresses.

**Secondary DNS:** The secondary DNS acts as a backup to the primary.

**Enable UPnP Presentation:** Enabling this setting allows your camera to be configured as a UPnP device on your network.

**Enable UPnP Port Forwarding:** Enabling this setting allows the camera to add port forwarding entries into the router automatically on a UPnP capable network.

The screenshot shows the D-Link web interface for the DCS-6314 camera. The top navigation bar includes 'LIVE VIDEO', 'SETUP', 'ADVANCED', 'MAINTENANCE', 'STATUS', and 'HELP'. The 'SETUP' tab is active, and the 'NETWORK SETUP' page is displayed. The page contains a 'LAN SETTINGS' section with the following options:

- DHCP
- Static IP Client
  - IP address: 192.168.1.101
  - Subnet mask: 255.255.255.0
  - Default router: 192.168.1.1
  - Primary DNS: 192.168.1.1
  - Secondary DNS: 0.0.0.0
- Enable UPnP presentation
- Enable UPnP port forwarding
  - Forwarding Port: 1024
  - Forwarding Status: UPnP forwarding is inactive

Helpful Hints on the right side of the page include:

- Select DHCP Connection:** If you are running a DHCP server on your network and would like an IP address assigned to your IP camera automatically.
- UPnP:** Enabling UPnP settings will allow you to configure your IP camera as an UPnP device in the network.
- PPPoE Setting:** If you use the IP camera to connect directly to the Internet, you will need to enter the username and password, which were given to you when you set up your account with your Internet Service Provider. If the camera is behind a router or a gateway, you do not need to configure this setting.

**Enable PPPoE:** Enable this setting if your network uses PPPoE.

**User Name / Password:** Enter the username and password for your PPPoE account. Re-enter your password in the Confirm Password field. You may obtain this information from your ISP.

**HTTP Port:** The default port number is 80.

**Access Name for Stream 1~3:** The default name is video#.mjpg, where # is the number of the stream.

**HTTPS Port:** You may use a PC with a secure browser to connect to the HTTPS port of the camera. The default port number is 443.

**Authentication:** Choose to enable or disable RTSP digest encryption. Digest encryption uses MD5 hashes.

**RTSP Port:** The port number that you use for RTSP streaming to mobile devices, such as mobile phones or PDAs. The default port number is 554. You may specify the address of a particular stream. For instance, live1.sdp can be accessed at rtsp://x.x.x.x/video1.sdp where the x.x.x.x represents the ip address of your camera.

**Enable CoS:** Enabling the Class of Service setting implements a best-effort policy without making any bandwidth reservations.

**Enable QoS:** Enabling QoS allows you to specify a traffic priority policy to ensure a consistent Quality of Service during busy periods. If the Network Camera is connected to a router that itself implements QoS, the router's settings will override the QoS settings of the camera.

PPPOE SETTINGS	
<input type="radio"/> Enable <input checked="" type="radio"/> Disable	
User Name	<input type="text"/>
Password	<input type="password"/>
Confirm password	<input type="password"/>
PPPoE Status	PPPoE is inactive.

HTTP	
HTTP port	<input type="text" value="80"/>
Access name for stream1	<input type="text" value="video1.mjpg"/>
Access name for stream2	<input type="text" value="video2.mjpg"/>

HTTPS	
HTTPS port	<input type="text" value="443"/>

RTSP	
Authentication	<input type="text" value="Disable"/>
RTSP port	<input type="text" value="554"/>
Access name for stream1	<input type="text" value="live1.sdp"/>
Access name for stream2	<input type="text" value="live2.sdp"/>

COS SETTINGS	
<input type="checkbox"/> Enable CoS	
VLAN ID	<input type="text" value="1"/> [0~4095]
Live video	<input type="text" value="0"/>
Live audio	<input type="text" value="0"/>
Event/Alarm	<input type="text" value="0"/>
Management	<input type="text" value="0"/>

QOS SETTINGS	
<input type="checkbox"/> Enable QoS	
Live video	<input type="text" value="0"/>
Live audio	<input type="text" value="0"/>
Event/Alarm	<input type="text" value="0"/>
Management	<input type="text" value="0"/>

**HTTP:** HTTP Port is the port you allocate in order to connect to the IP camera via a standard web browser.

**HTTPS:** HTTPS Port in a IP camera connects it with a PC via a secure web browser.

**RTSP:** RTSP Port is the port you allocate in order to connect to a IP camera by using streaming mobile device(s), such as a mobile phone or PDA.

**CoS (Class of Service):** Coarsely-grained traffic control based on the L2 protocol. Class of Service technologies do not guarantee a level of service in terms of bandwidth and delivery time, they offer a "best-effort".

**QoS (Quality of Service):** Finely-grained traffic control, a resource reservation control mechanism. Quality of service guarantees are important if the network capacity is insufficient, especially for real-time streaming multimedia applications.

**Enable IPv6:** Select this option and click Save to enable IPv6 setting. Please note that this only works if your network environment and hardware equipment support IPv6. The browser should be Microsoft @ Internet Explorer 6.5, Mozilla Firefox 3.0 or above. When IPv6 is enabled, by default, the Network Camera will listen to router advertisements and be assigned a link-local IPv6 address accordingly.

**IPv6 Information:** Click this button to obtain the IPv6 information. If your IPv6 setting are successful, the IPv6 address list will be listed



**Enable IPv6:** Enable the IPv6 setting to use the IPv6 protocol. Enabling the option allows you to manually set up the address, specify an optional IP address, specify an optional router and an optional primary DNS.

**Enable Multicast for stream:** The DCS-6314 allows you to multicast each of the available streams via group address and specify the TTL value for each stream. Enter the port and TTL settings you wish to use if you do not want to use the defaults.

After making any changes, click the **Save Settings** button to save your changes.

The screenshot displays the configuration interface for IPv6 and Multicast settings. The IPv6 section includes an 'Enable IPv6' checkbox and an 'IPv6 Information' button. Below this, there are fields for 'Manually setup the IP address', 'Optional IP address / Prefix length' (with a default of /64), 'Optional default router', and 'Optional primary DNS'. The Multicast section is divided into two streams. Stream 1 has fields for 'Multicast group address' (239.1.1.1), 'Multicast video port' (6550), 'Multicast RTCP video port' (6551), 'Multicast audio port' (6552), 'Multicast RTCP audio port' (6553), and 'Multicast TTL [1~255]' (64). Stream 2 has fields for 'Multicast group address' (239.1.1.2), 'Multicast video port' (6554), 'Multicast RTCP video port' (6555), 'Multicast audio port' (6556), 'Multicast RTCP audio port' (6557), and 'Multicast TTL [1~255]' (64). At the bottom, there are 'Save Settings' and 'Don't Save Settings' buttons.

**IPv6**

Enable IPv6

**IPv6 Information**

Manually setup the IP address

Optional IP address / Prefix length: [ ] / 64

Optional default router: [ ]

Optional primary DNS: [ ]

**MULTICAST**

Enable multicast for stream 1

Multicast group address: 239.1.1.1

Multicast video port: 6550

Multicast RTCP video port: 6551

Multicast audio port: 6552

Multicast RTCP audio port: 6553

Multicast TTL [1~255]: 64

Enable multicast for stream 2

Multicast group address: 239.1.1.2

Multicast video port: 6554

Multicast RTCP video port: 6555

Multicast audio port: 6556

Multicast RTCP audio port: 6557

Multicast TTL [1~255]: 64

[ Save Settings ] [ Don't Save Settings ]

**in the pop-up window. Please follow the steps below to link to an IPv6 address:**

- 1) Open your web browser.
- 2) Enter the link-global or link-local IPv6 address in the address bar of your web browser.
- 3) Press Enter on the keyboard or click Refresh button to refresh the webpage.

**Manually setup the IP address:** Select this option to manually configure IPv6 setting if your network environment does not have DHCPv6 server and advertisements-enabled routers.

**Multicast:** Click the items to display the detailed configuration information. Select the Always multicast option to enable multicast for stream 1 ~ 3. Unicast video transmission delivers a stream through point-to-point transmission; multicast, on the other hand, sends a stream to the multicast group address and allows multiple clients to acquire the stream at the same time by requesting a copy from the multicast group address. Therefore, enabling multicast can effectively save network bandwidth.

Multicast RTCP video

## Dynamic DNS

DDNS (Dynamic Domain Name Server) will hold a DNS host name and synchronize the public IP address of the modem when it has been modified. A user name and password are required when using the DDNS service. After making any changes, click the **Save Settings** button to save your changes.

**Enable DDNS:** Select this checkbox to enable the DDNS function.

**Server Address:** Select your Dynamic DNS provider from the pull down menu or enter the server address manually.

**Host Name:** Enter the host name of the DDNS server.

**User Name:** Enter the user name or e-mail used to connect to your DDNS account.

**Password:** Enter the password used to connect to your DDNS server account.

**Timeout:** Enter the DNS timeout values you wish to use.

**Status:** Indicates the connection status, which is automatically determined by the system.

The screenshot shows the D-Link DCS-6314 web interface. The top navigation bar includes 'LIVE VIDEO', 'SETUP', 'ADVANCED', 'MAINTENANCE', 'STATUS', and 'HELP'. The 'SETUP' menu is expanded, showing options like 'Setup Wizard', 'Network Setup', 'Dynamic DNS', 'Image Setup', 'Audio and Video', 'Preset', 'Motion Detection', 'Time and Date', 'Event Setup', 'SD Card', and 'Logout'. The 'Dynamic DNS' section is highlighted, containing an explanatory text: 'The Dynamic DNS feature allows you to use a domain name that you have purchased (www.yourdomain.com) to access your IP camera with a dynamically assigned IP address. Most broadband Internet service providers assign dynamic (changing) IP addresses. By using a DDNS service, you can enter your domain name to connect to your IP camera no matter what your IP address is.' Below this text is a link: 'Sign up for D-Link's Free DDNS service at www.DLinkDDNS.com.' and two buttons: 'Save Settings' and 'Don't Save Settings'. The 'Dynamic DNS Setting' form includes: 'Enable DDNS' (checkbox), 'Server Address' (text input with a dropdown menu showing 'www.dlinkddns.com'), 'Host Name' (text input), 'User Name' (text input), 'Password' (text input), 'Verify Password' (text input), 'Timeout' (text input with '24' and '(hours)'), and 'Status' (text input with 'Inactive'). At the bottom of the form are 'Save Settings' and 'Don't Save Settings' buttons. A 'Helpful Hints..' sidebar on the right states: 'Dynamic DNS is useful if you have a DSL or Cable service provider that changes your modem IP address periodically. This will allow you to assign a website domain name to your IP camera instead of connecting through an IP address.'

## Image Setup

In this section, you may configure the video image settings for your camera. A preview of the image will be shown in Live Video.

**Enable Privacy Mask** The Privacy Mask setting allows you to specify up to 3 rectangular areas on the camera's image to be blocked/excluded from recordings and snapshots.

You may click and drag the mouse cursor over the camera image to draw a mask area. Right clicking on the camera image brings up the following menu options:

Disable All: Disables all mask areas  
 Enable All: Enables all mask areas  
 Reset All: Clears all mask areas.

**Mirror:** This will mirror the image horizontally.

**Flip:** This will flip the image vertically. When turning Flip on, you may want to consider turning Mirror on as well.

**Power Line:** Select the frequency used by your power lines to avoid interference or distortion.

**White Balance:** Use the drop-down box to change white balance settings to help balance colors for different environments. You can choose from Auto, Outdoor, Indoor, Fluorescent, and Push Hold. Changes the exposure mode. Use the drop-down

The screenshot shows the D-Link DCS-6314 web interface. The top navigation bar includes 'LIVE VIDEO', 'SETUP', 'ADVANCED', 'MAINTENANCE', 'STATUS', and 'HELP'. The 'SETUP' menu is expanded, showing options like 'Setup Wizard', 'Network Setup', 'Dynamic DNS', 'Image Setup', 'Audio and Video', 'Preset', 'Motion Detection', 'Time and Date', 'Event Setup', 'SD Card', and 'Logout'. The 'IMAGE SETUP' page is active, displaying a live video preview of a street scene. Below the preview, the 'IMAGE SETTINGS' section includes:

- Mirror:  On  Off
- Flip:  On  Off
- Power Line:  60 Hz  50 Hz
- White Balance: Auto
- Exposure Mode: Customize1 Max Gain 36 dB
- Shutter: Min: 1/30 Max: 1/30
- Denoise: 0
- Brightness: 128
- Contrast: 128
- Saturation: 128
- Sharpness: 128
- WDR Level: WDR 5

A 'Reset Default' button is located at the bottom of the settings section. On the right side, a 'Helpful Hints...' sidebar provides additional information:

- Privacy Mask:** Click the attached box to activate this function. Now use your mouse to draw a rectangle covering the area you want hidden. Click the box again to deactivate the function.
- Mirror:** This function horizontally reverses your images 180 degrees.
- Flip:** This function vertically reverses your images 180 degrees.
- Power Line:** This setting is used to remove 50/60 Hz flicker.
- White Balance:** White Balance - Is the process of removing unrealistic color casts, so that objects which appear white in person are rendered white in your photo.
- Exposure Mode:** Exposure is the total amount of light allowed to fall on the image sensor during the process of capturing an image. You may choose different scene modes to produce the better images.
- Max Gain:** It can always be enabled automatically. But you have an option - you can change Max Gain either automatically or manually.
- Denoise:** It is the process of removing noise from a signal.
- Brightness:** It is used to

**Exposure Mode:** box to set the camera for Indoor, Outdoor, or Night environments, or to Moving to capture moving objects. The Low Noise option will focus on creating a high-quality picture without noise. You can also create 3 different custom exposure modes. The Max Gain setting will allow you to control the maximum amount of gain to apply to brighten the picture.

**Denoise:** This setting controls the amount of noise reduction that will be applied to the picture.

**Brightness:** Adjust this setting to compensate for backlit subjects.

**Contrast:** Adjust this setting to alter the color intensity/strength.

**Saturation:** This setting controls the amount of coloration, from grayscale to fully saturated.

**Sharpness:** Specify a value from 0 to 128 to specify how much sharpening to apply to the image.

**WDR Level:** Specify a value from 0 to 10 to specify how much WDR to apply to the image, or select None.

**Reset Default:** Click this button to reset the image to factory default settings.

The screenshot shows the D-Link DCS-6314 web interface. The top navigation bar includes 'LIVE VIDEO', 'SETUP', 'ADVANCED', 'MAINTENANCE', 'STATUS', and 'HELP'. The 'SETUP' menu is expanded to show 'Image Setup' as the active page. The main content area is titled 'IMAGE SETUP' and contains a message: 'Changes to your IP camera settings are made immediately.' Below this is a 'LIVE VIDEO' section with a checkbox for 'Enable Privacy Mask Setting' and a live video feed of a street scene. The 'IMAGE SETTINGS' section includes the following controls:

- Mirror:  On  Off
- Flip:  On  Off
- Power Line:  60 Hz  50 Hz
- White Balance:
- Exposure Mode:  Max Gain  dB
- Shutter: Min:  Max:
- Denoise:
- Brightness:
- Contrast:
- Saturation:
- Sharpness:
- WDR Level:

A 'Reset Default' button is located at the bottom of the settings section. On the right side of the interface, there is a 'Helpful Hints...' section with the following information:

- Privacy Mask:** Click the attached box to activate this function. Now use your mouse to draw a rectangle covering the area you want hidden. Click the box again to deactivate the function.
- Mirror:** This function horizontally reverses your images 180 degrees.
- Flip:** This function vertically reverses your images 180 degrees.
- Power Line:** This setting is used to remove 50/60 Hz flicker.
- White Balance:** White Balance - Is the process of removing unrealistic color casts, so that objects which appear white in person are rendered white in your photo.
- Exposure Mode:** Exposure is the total amount of light allowed to fall on the image sensor during the process of capturing an image. You may choose different scene modes to produce the better images.
- Max Gain:** It can always be enabled automatically. But you have an option - you can change Max Gain either automatically or manually.
- Denoise:** It is the process of removing noise from a signal.

## Audio and Video

You may configure up to 3 video profiles with different settings for your camera. Hence, you may set up different profiles for your computer and mobile display. In addition, you may also configure the two-way audio settings for your camera. After making any changes, click the **Save Settings** button to save your changes.

**Aspect ratio:** Set the aspect ratio of the video to 4:3 standard or 16:9 widescreen.

**Mode:** Set the video codec to be used to JPEG, MPEG-4, or H.264.

**Frame size / View window area:** The field of view for the DCS-6314 is fixed based on its mounted orientation. The ePTZ function requires that the frame size is larger than the view window area in order to allow the user to pan, tilt, and zoom within the image. The frame size determines the actual image size that is captured by the DCS-6314. The view window area can be set to a smaller area in order to help focus in on certain parts of the larger frame size that is captured. If you want to use the ePTZ or Global View function on the Live View page, the frame size should always be set larger than the view window size when setting video profiles.

16:9 1920 x 1080, 1280 x 720, 800 x 450,  
640 x 360, 480 x 270, 320 x 176, 176 x  
144 up to 30 fps

4:3 1440 x 1080, 1280 x 960, 1024 x 768,  
800 x 600, 640 x 480, 320 x 240, 176 x  
144 up to 30 fps

**Note:** If your View window area is the same as your Frame size, you will not be able to use the ePTZ function.

**D-Link**

DCS-6314 // LIVE VIDEO SETUP ADVANCED MAINTENANCE STATUS HELP

Setup Wizard  
Network Setup  
Dynamic DNS  
Image Setup  
Audio and Video  
Preset  
Motion Detection  
Time and Date  
Event Setup  
SD Card  
Logout

**AUDIO AND VIDEO**

This section allows you to configure the sound and video of your camera. You can configure different settings depending on whether you are viewing content from a PC or a Mobile Phone / PDA.

Save Settings Don't Save Settings

**VIDEO SETTINGS**

Number of active profiles 2

Aspect ratio 16:9 **Warning: Change the aspect ratio will clear the settings of privacy mask and preset and motion detection.**

Save Default

**VIDEO PROFILE 1**

Mode H.264

Frame size 640x360

View window area 640x360

**Helpful Hints..**

Higher frame size, frame rate and bit rate gives better video quality. At the same time, it requires more network bandwidth.

For best viewing results on a mobile phone, we suggest setting the Frame Rate to 5fps and the Bit Rate to 64 kbps.

**Number of active profiles:** Number of profiles that you wish to active. The maximum profiles are three.

**Aspect Ratio:** An aspect ratio is the ratio between the width and height of an image.

**Mode:** It can be H.264, JPEG, or MPEG4. In JPEG mode, the video frames

**Maximum frame rate:** A higher frame rate provides smoother motion for videos, and requires more bandwidth. Lower frame rates will result in stuttering motion, and requires less bandwidth.

**Video Quality:** This limits the maximum frame rate, which can be combined with the "Fixed quality" option to optimize the bandwidth utilization and video quality. If fixed bandwidth utilization is desired regardless of the video quality, choose "Constant bit rate" and select the desired bandwidth.

**Constant bit rate:** The bps will affect the bit rate of the video recorded by the camera. Higher bit rates result in higher video quality.

**Fixed quality:** Select the image quality level for the camera to try to maintain. High quality levels will result in increased bit rates.

**Audio in off:** Selecting this checkbox will mute incoming audio.

**Audio in gain level:** This setting controls the amount of gain applied to incoming audio to increase its volume.

**Audio out off:** Selecting this checkbox will mute outgoing audio.

**Audio out volume level:** This setting controls the amount of gain applied to outgoing audio to increase its volume.

The screenshot displays the configuration interface for a camera, divided into three main sections: Video Profile 2, Video Profile 1, and Audio Settings. At the top, there are controls for Maximum frame rate (set to 25), Video quality (Constant bit rate selected with 2M, and Fixed quality selected with Excellent), and Frame size (set to 640x360). The Video Profile 2 section includes Mode (JPEG), Frame size (640x360), View window area (640x360), Maximum frame rate (25), and Video quality (Excellent). The Audio Settings section includes Encoding (G.711), Audio in off (unchecked), Audio in gain level (20dB), Audio out off (unchecked), and Audio out volume level (10). At the bottom, there are buttons for 'Save Settings' and 'Don't Save Settings'. On the right side, there is a vertical text box providing additional information: 'consumes much less network bandwidth than JPEG, and H.264 can use less bandwidth but better image quality.', 'Frame Size: 7 options exist for the sizes of the video display. It is recommended using 176x144 for mobile viewing and 1920x1080 for computer viewing.', 'View window area: The viewing region of the current video stream.', 'Max frame rate: The maximum number of frames that is displayed in 1 second. 30fps is the highest video quality for this camera. In general, any frame rate above 15 fps is imperceptible to the human eye.', and 'Video Quality: This limits the maximal refresh frame rate, which can be combined with the "Fixed quality" to optimize the bandwidth utilization and video quality. If the User wants to fix the bandwidth utilization regardless of the video quality, choose "Constant bit rate" and select the

## Preset

This screen allows you to set preset points for the ePTZ function of the camera, which allows you to look around the camera's viewable area by using a zoomed view. Presets allow you to quickly go to and view a specific part of the area your camera is covering, and you can create preset sequences, which will automatically change the camera's view between the different presets according to a defined order and timing you can set.

**Note:** If your View window area is the same as your Frame size, you will not be able to use the ePTZ function.

**Video Profile:** This selects which video profile to use.

**ePTZ Speed:** You may select a value between 0 and 10. 0 is the slowest and 10 is the fastest.

**Arrow Buttons and Home Button:** Use these buttons to move to a specific part of the viewing area, which you can then set as a preset. Click the Home button to return to the center of the viewing area.

**Input Preset Name:** Enter the name of the preset you want to create, then click the **Add** button to make a new preset. If an existing preset has been selected from the Preset List, you can change its name by typing in a new name, then clicking the **Rename** button.

**Preset List:** Click this drop-down box to see a list of all the presets that have been created. You can select one, then click the **GoTo** button to change the displayed camera view to the preset. Clicking the **Remove** button will delete the currently selected preset.

The screenshot shows the D-Link DCS-6314 camera web interface. The top navigation bar includes tabs for LIVE VIDEO, SETUP, ADVANCED, MAINTENANCE, STATUS, and HELP. The left sidebar lists various setup options: Setup Wizard, Network Setup, Dynamic DNS, Image Setup, Audio and Video, Preset, Motion Detection, Time and Date, Event Setup, SD Card, and Logout. The main content area is titled "PRESET CONTROL" and contains the following elements:

- PRESET CONTROL** header with a sub-header: "Using the Pan and Tilt controls, move the camera view to the required position. There are provides the tools for creating and saving Preset positions & Preset Sequence."
- A live video feed showing a street scene with a building, overlaid with a red dashed box indicating the current view area.
- Control buttons: Up, Down, Left, Right, and Home (center).
- VIDEO PROFILE : 2 (dropdown)
- ePTZ Speed : 5 (dropdown)
- PRESET** section with:
  - Input Preset Name :  **Add** **Rename**
  - Support(0~9,A~Z,a~z,-,\*,/,\_)
  - Preset List : --Preset List-- **GoTo** **Remove**

The right sidebar contains "Helpful Hints..":

- Input Preset Name:** Using the Pan, Tilt and Zoom (PTZ) controls, move the camera view to the required position and simply by selecting the preset's name.
- Add:** This camera position is then saved as a preset position in the camera.
- GoTo:** for test the preset the preset position.
- Preset Sequence:** A preset sequence is an automated series of camera movements from one preset position to another. A guard tour can be set up to display the video streams from different preset positions in a pre-determined order, and for configurable time periods.
- Add:** set up a new preset sequence, Modify to

**Preset Sequence:** This section allows you to create a preset sequence, which automatically moves the camera's view between a set of preset views.

**Preset List:** To add a preset to the sequence, select it from the drop-down box at the bottom of this window, set the **Dwell time** to determine how long the camera view will stay at that preset, then click the **Add** button. The preset name will appear in the list, followed by the dwell time to view that preset for.

You can rearrange your presets in the sequence by selecting a preset in the sequence, then clicking the arrow buttons to move it higher or lower in the current sequence.

Clicking the trash can button will remove the currently selected preset from the sequence.

If you want to change the dwell time for a preset, select it from the list, enter a new dwell time, then click the **Update** button.

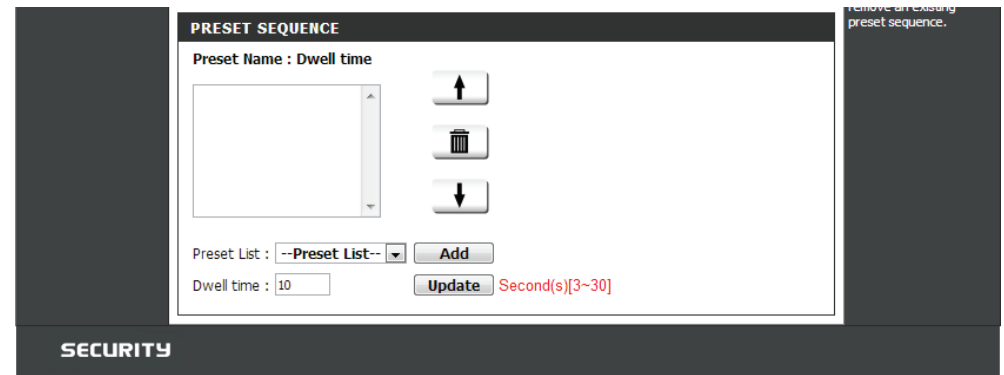



## Motion Detection

Enabling Video Motion will allow your camera to use the motion detection feature. You may draw a finite motion area that will be used for monitoring. After making any changes, click the **Save Settings** button to save your changes.

**Enable Video Motion:** Select this box to enable the motion detection feature of your camera.

**Sensitivity:** Specifies the measurable difference between two sequential images that would indicate motion. Please enter a value between 0 and 100.

**Percentage:** Specifies the amount of motion in the window being monitored that is required to initiate an alert. If this is set to 100%, motion is detected within the whole window will trigger a snapshot.

**Draw Motion Area:** Draw the motion detection area by dragging your mouse in the window (indicated by the red square).

**Erase Motion Area:** To erase a motion detection area, simply click on the red square that you wish to remove.

Right clicking on the camera image brings up the following menu options:

**Select All:** Draws a motion detection area over the entire screen.

**Clear All:** Clears any motion detection areas that have been drawn.

**Restore:** Restores the previously specified motion detection areas.

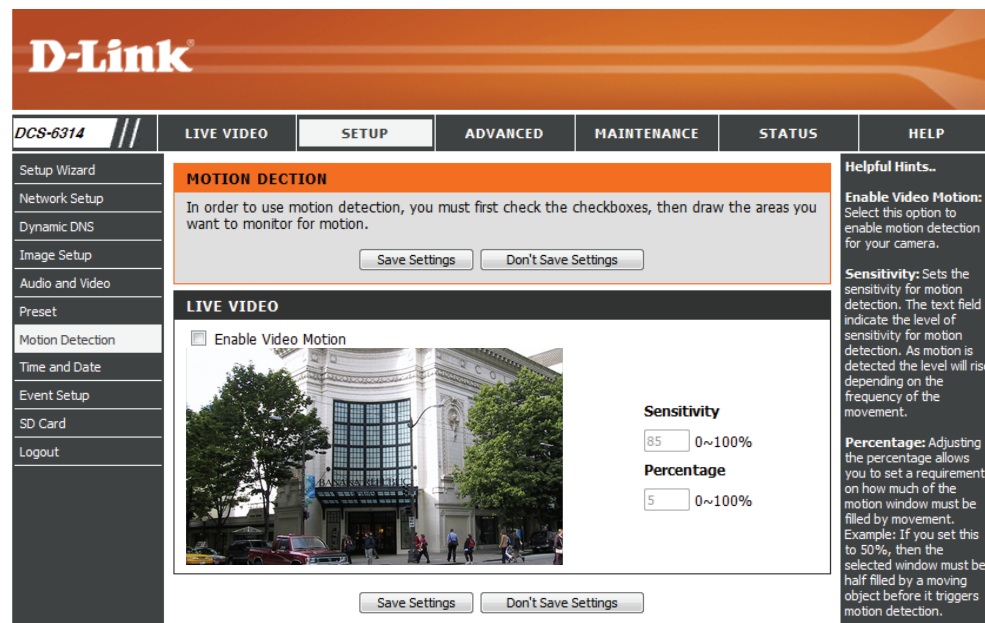
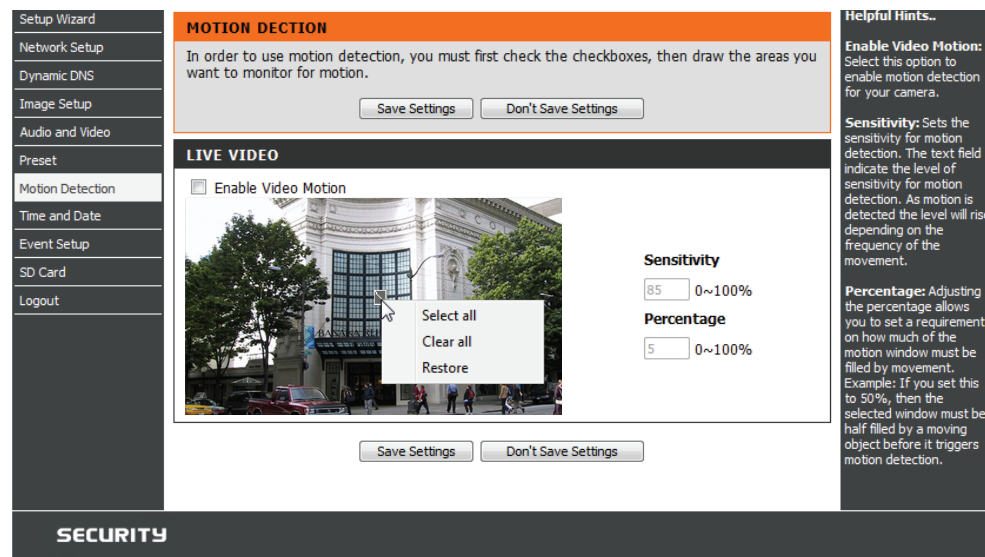
## Time and Date

This section allows you to automatically or manually configure, update, and maintain the internal system clock for your camera. After making any changes, click the **Save Settings** button to save your changes.

**Time Zone:** Select your time zone from the drop-down menu.

**Enable Daylight Saving:** Select this to enable Daylight Saving Time. Select this option to allow your camera to configure the Daylight Saving settings automatically.

**Auto Daylight Saving:** Selecting this option allows you to configure the Daylight Saving date and time manually.

**Set Date and Time Manually:** Sets the amount of time to be added or removed when Daylight Saving is enabled.

**Offset:** Enable this feature to obtain time automatically from an NTP server.

**Synchronize with NTP Server:** Network Time Protocol (NTP) synchronizes the DCS-6314 with an Internet time server.

**NTP Server:** Choose the one that is closest to your location.

**Set the Date and Time Manually:** This option allows you to set the time and date manually.

**Copy Your Computer's Time Settings:** This will synchronize the time information from your PC.

**TIME AND DATE**

You can set the current time for the IP camera.

Save Settings Don't Save Settings

**TIME CONFIGURATION**

Time Zone (UTC+08:00) Taipei

Enable Daylight Saving

Auto Daylight Saving

Set date and time manually

Offset +2:00

Start time Month Week Day of week Hour Minutes  
5 1 Sunday 00 00

End time Month Week Day of week Hour Minutes  
10 1 Sunday 00 00

**AUTOMATIC TIME CONFIGURATION**

Synchronize with NTP Server

NTP Server ntp.dlink.com.tw << Select NTP Server

**SET DATE AND TIME MANUALLY**

Set date and time manually

Year 2013 Month 1 Day 21

Hour 3 Minute 45 Second 22

Copy Your Computer's Time Settings

Save Settings Don't Save Settings

**Helpful Hints..**

Good timekeeping is important for accurate logs and scheduled firewall rules.

**Time Zone:** Select your time zone from the drop-down menu.

**Enable Daylight Saving:** Select this to enable the daylight saving time.

**Auto Daylight Saving:** When you select it, the clock is automatically adjusted according to the daylight saving time of the selected time zone.

**Offset:** Select the time offset, if your location observes daylight saving time.

**Synchronize with NTP Server:** With the option selected, the camera will synchronize the time settings with the NTP server over the Internet whenever the camera starts up. If the timeserver cannot be reached, no time settings will be applied.

**NTP Server:** Network Time Protocol (NTP) synchronizes the IP camera with an Internet time server. Choose the one that is closest to your location.

**Copy Your Computer's Time**

## Event Setup

In a typical application, when motion is detected, the DCS-6314 sends images to a FTP server or via e-mail as notifications. As shown in the illustration below, an event can be triggered by many sources, such as motion detection. When an event is triggered, a specified action will be performed. You can configure the Network Camera to send snapshots or videos to your e-mail address or FTP site.

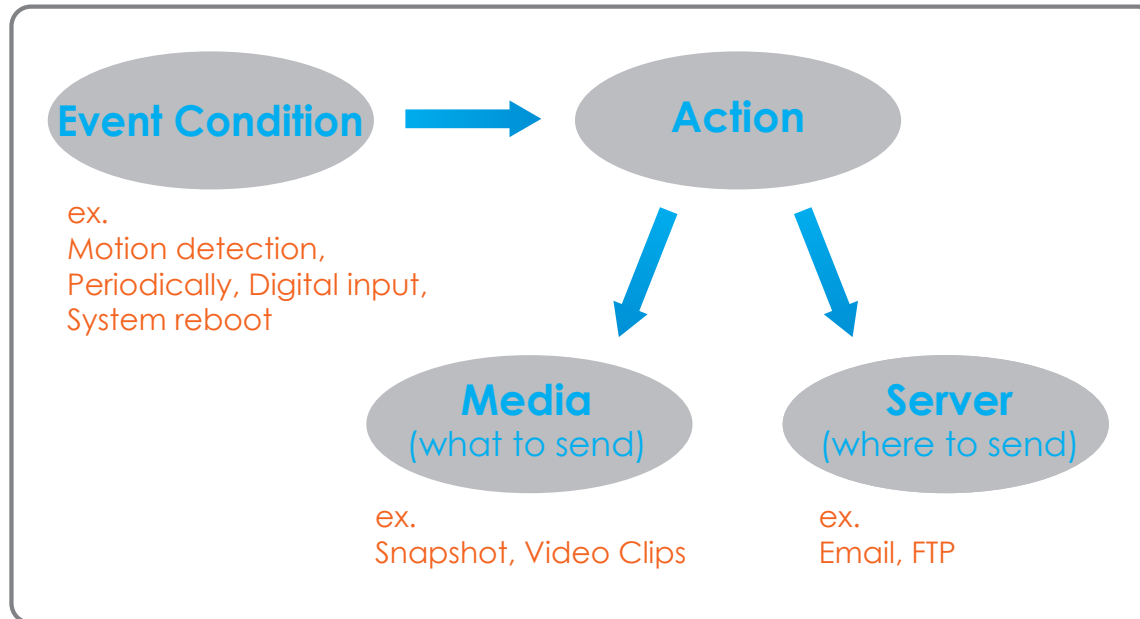

To start plotting an event, it is suggested to configure server and media columns first so that the Network Camera will know what action shall be performed when a trigger is activated.

The Event Setup page includes 4 different sections.

- Server
- Media
- Event
- Recording

1. To add a new item - "event, server or media," click **Add**. A screen will appear and allow you to update the fields accordingly.
2. To delete the selected item from the pull-down menu of event, server or media, click **Delete**.
3. Click on the item name to pop up a window for modifying.

**D-Link**

DCS-6314 // LIVE VIDEO SETUP ADVANCED MAINTENANCE STATUS HELP

**EVENT SETUP**

There are four sections in Event Setup page. They are event, server, media and recording. Click Add to pop a window to add a new item of event, server, media or recording. Click Delete to delete the selected item from event, server, media or recording. Click on the item name to pop a window to edit it. There can be at most 3 events and 2 recording. There can be at most 5 server and 5 media configurations.

**SERVER**

Name	Type	Address/Location
<input type="button" value="Add"/>	<input type="button" value="Delete"/>	

**MEDIA**

Name	Type	Source
<input type="button" value="Add"/>	<input type="button" value="Delete"/>	

**EVENT**

Name	Status	Sun	Mon	Tue	Wed	Thu	Fri	Sat	Time	Trigger
<input type="button" value="Add"/>	<input type="button" value="Delete"/>									

**RECORDING**

Name	Status	Sun	Mon	Tue	Wed	Thu	Fri	Sat	Time	Source	Destination
<input type="button" value="Add"/>	<input type="button" value="Delete"/>										

**Helpful Hints..**

Suggest setting server and media first before setting event. The servers and media which selected in event list are not be able to modify or delete. Please remove them first from the event if you want to delete or modify them. Recommend using different media in different event to make use all media be produced and received correctly. If using the same media in different events and the events trigger almost simultaneously, the servers in the second triggered event will not receive any media; there would be only notifications.

**SECURITY**

## Add Server

You can configure up to 5 servers to save snapshots and/or video to. After making any changes, click the **Save Settings** button to save your changes.

**Server Name:** Enter the unique name of your server.

**E-mail:** Enter the configuration for the target e-mail server account.

**FTP:** Enter the configuration for the target FTP server account.

**Network Storage:** Specify a network storage device. Only one network storage device is supported.

**SD Card:** Use the camera's onboard SD card storage.

The screenshot shows the 'Add Server' configuration page in the D-Link DCS-6314 web interface. The page is titled 'SERVER' and contains a 'SERVER TYPE' section with radio buttons for 'Email', 'FTP', 'Network storage', and 'SD Card'. Each type has associated input fields for server details. A 'Helpful Hints...' sidebar on the right provides definitions for terms like 'Server name', 'Email address', 'FTP server', and 'Network storage'. The interface includes a navigation menu on the left and a 'SECURITY' footer.

**SERVER**  
You can set at most 5 different servers here for different event.  
[Test] [Save Settings] [Don't Save Settings]

**SERVER TYPE**

Server Name: [ ]

**Email**

Sender email address [ ]

Recipient email address [ ]

Server address [ ]

User name [ ]

Password [ ]

Port [ 25 ]

This server requires a secure connection (StartTLS)

**FTP**

Server address [ ]

Port [ 21 ]

User name [ ]

Password [ ]

Remote folder name [ ]

Passive mode

**Network storage**

Network storage location [ ]  
(for example: \\my\_nas\disk\folder)

Workgroup [ ]

User name [ ]

Password [ ]

Primary WINS server [ ]

**SD Card**

[Test] [Save Settings] [Don't Save Settings]

**Helpful Hints..**

**"Server name"** The unique name for server. There are four kinds of servers supported. They are email server, FTP server, HTTP server and network storage.

**Email server:** "Sender email address" The email address of the sender. "Recipient email address" The email address of the recipient.

**FTP server:** "Remote folder name" Granted folder on the external FTP server. The string must conform to that of the external FTP server. Some FTP servers cannot accept preceding slash symbol before the path without virtual path mapping. Refer to the instructions for the external FTP server for details. The folder privilege must be open for upload. "Passive Mode" Check it to enable passive mode in transmission.

**Network storage:** Only one network storage is supported. "Network storage location" The path to upload the media. "Workgroup" The workgroup for network storage.

**SD card:** Use the SD card for recording media.

**SECURITY**

## Add Media

There are three types of media, **Snapshot**, **Video Clip**, and **System Log**. After making any changes, click the **Save Settings** button to save your changes.

**Media Name:** Enter a unique name for media type you want to create.

**Snapshot:** Select this option to set the media type to snapshots.

**Source:** Set the video profile to use as the media source. Refer to **Audio and Video** on "Audio and Video" on page 45 for more information on video profiles.

**Send pre-event image(s) [0~4]:** Set the number of pre-event images to take. Pre-event images are images taken before the main event snapshot is taken.

**Send post-event image(s) [0~7]:** Set the number of post-event images to take. Post-event images are images taken after the main event snapshot is taken. You can set up to 7 post-event images to be taken.

**File name prefix:** The prefix name will be added on the file name.

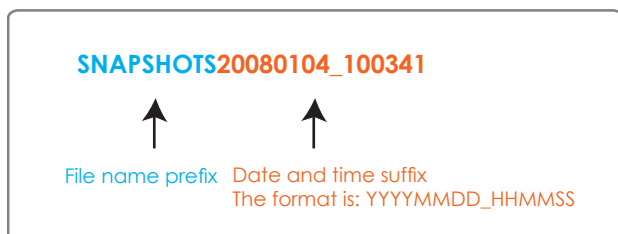

**D-Link**

DCS-6314 // LIVE VIDEO SETUP ADVANCED MAINTENANCE STATUS HELP

**MEDIA**

You can set at most 5 different media here for different event.

Save Settings Don't Save Settings

**MEDIA TYPE**

Media name:

Snapshot

Source: Profile1

Send  pre-event image(s) [0~4]

Send  post-event image(s) [0~7]

File Name Prefix:

Add date and time suffix to file name

Video Clip

Source: Profile1

Pre-event recording:  Second(s) [0~4]

Maximum duration:  Second(s) [1~100]

Maximum file size:  Kbytes [100~5000]

File Name Prefix:

System log

Save Settings Don't Save Settings

**Helpful Hints..**

"Media name" The unique name for media. There are three kinds of media. They are snapshot, video clip and system log.

**Snapshot:**

"Source" The source of profile, profile1 or profile2.

"Send Pre-event images" The number of pre-event images.

"Send Post-event images" The number of post-event images.

"File name prefix" The prefix name will be added on the file name of the snapshot images.

"Add date and time suffix to file name" Check it to add timing information as file name suffix.

**Video clip:**

"Source" The source of profile, profile1 or profile2.

"Pre-event recording" The interval of pre-event recording in seconds There are two limitations for video clip file.

"Maximum duration" The maximal recording file duration in seconds.

"Maximum file size"

**Add date and time suffix to file name:** Check this to add timing information as file name suffix. Please see the previous page for an example on how the file name will be determined if this option is enabled.

**Video clip:** Select this option to set the media type to video clips.

**Source:** Set the video profile to use as the media source. Refer to "Audio and Video" on page 45 for more information on video profiles.

**Pre-event recording:** This sets how many seconds to record before the main event video clip starts. You can record up to 4 seconds of pre-event video.

**Maximum duration:** Set the maximum length of video to record for your video clips.

**Maximum file size:** Set the maximum file size to record for your video clips.

**System log:** Select this option to set the media type to system logs. This will save the event to the camera system log, but will not record any snapshots or video.

## Add Event

Create and schedule up to 3 events with their own settings here. After making any changes, click the **Save Settings** button to save your changes.

**Event name:** Enter a name for the event.

**Enable this event:** Select this box to activate this event.

**Priority:** Set the priority for this event. The event with higher priority will be executed first.

**Delay:** Select the delay time before checking the next event. It is being used for both events of motion detection and digital input trigger.

**Video Motion Detection:** Motion is detected during live video monitoring. Select the windows that need to be monitored.

**Periodic:** The event is triggered in specified intervals. The trigger interval unit is in minutes.

**Digital Input:** The external trigger input to the camera.

**System Boot:** Triggers an event when the system boots up.

**Network Lost:** Triggers an event when the network connection is lost.

**Time:** Select **Always** or enter the time interval.

**Trigger D/O:** Specify the amount of time in seconds if an event is triggered

**EVENT**

You can set at most 3 events like motion detection or digital input trigger here and arrange the detection schedule at the same time.

Save Settings Don't Save Settings

**EVENT**

Event name:

Enable this event

Priority: normal

Delay for 10 seconds before detecting next event [For motion detection and digital input]

**TRIGGER**

Video motion detection

Periodic

Trigger every 1 minutes

Digital input

System boot

Network lost

**EVENT SCHEDULE**

Sun  Mon  Tue  Wed  Thu  Fri  Sat

**Time**

Always

From 00 To 23 59

**ACTION**

Trigger D/O for 1 seconds

Save Settings Don't Save Settings

**Helpful Hints..**

**Priority:** The event with higher priority will be executed first.

There are five kinds of trigger supported.

**Video motion detection:** Select the windows which need to be monitored.

**Periodic:** The event is triggered in specified intervals. The unit of trigger interval is minute.

**Digital input:** The event is triggered when the DI status changed by external device.

**System boot:** The event is triggered when the system boot up.

**Network lost:** The event is triggered when the network service is not available or disconnection.

**Sun ~ Sat:** Select the days of the week to perform the event.

**Time:** show "Always" or input the time interval.

The default action are triggering DO and storing media on SD card. If there are servers configured, the user can select them from "Server name", too.

**Trigger DO:** Check it to trigger digital output for specific seconds when event is triggered.

Note: Please Format SD card before use. The entire data in the SD card.



## Add Recording

Here you can configure and schedule the recording settings. After making any changes, click the **Save Settings** button to save your changes.

**Recording entry name:** The unique name of the entry.

**Enable this recording:** Select this to enable the recording function.

**Priority:** Set the priority for this entry. The entry with a higher priority value will be executed first.

**Source:** The source of the stream.

**Recording schedule:** Scheduling the recording entry.

The screenshot shows the D-Link DCS-6314 web interface. The top navigation bar includes 'LIVE VIDEO', 'SETUP', 'ADVANCED', 'MAINTENANCE', 'STATUS', and 'HELP'. The left sidebar lists various setup options: Setup Wizard, Network Setup, Dynamic DNS, Image Setup, Audio and Video, Preset, Motion Detection, Time and Date, Event Setup, SD Card, and Logout. The main content area is titled 'RECORDING' and contains the following sections:

- RECORDING (Summary):** A message stating 'You can setup schedule recording to network storage with your specify week day and time period.' with 'Save Settings' and 'Don't Save Settings' buttons.
- RECORDING (Configuration):** A 'Recording entry name' text field, an 'Enable this recording' checkbox, a 'Priority' dropdown menu (set to 'normal'), and a 'Source' dropdown menu (set to 'Profile 1').
- RECORDING SCHEDULE:** A section with checkboxes for days of the week (Sun, Mon, Tue, Wed, Thu, Fri, Sat), all of which are checked. Below this is a 'Time' section with radio buttons for 'Always' (selected) and 'From' (with dropdowns for hours and minutes) and 'To' (with dropdowns for hours and minutes).

On the right side of the interface, there is a 'Helpful Hints..' section with the following text:

- Recording:** Enable this option if you want to upload the recording to a shared folder on the network.
- Recording schedule:** Select the day(s) according to when you want the IP camera to make a video clip.
- Always:** This enables the IP camera to make video clips continuously.
- From:** The time range specified for the video clip.
- Total cycling recording size:** Please input the network path of your network storage, it will like "\\DNS\IPCamRecord\". If the network storage need authentication, please enter your user name and password.

**Recording settings:** Configuring the setting for the recording.

**Destination:** Select the folder where the recording file will be stored.

**Total cycling recording size:** Please input a HDD volume between 1MB and 2TB for recording space. The recording data will replace the oldest record when the total recording size exceeds this value. For example, if each recording file is 6MB, and the total cyclical recording size is 600MB, then the camera will record 100 files in the specified location (folder) and then will delete the oldest file and create new file for cyclical recording.

**Size of each file for recording:** If this is selected, files will be separated based on the file size you specify.

**Time of each file for recording:** If this is selected, files will be separated based on the maximum length you specify.

**File Name Prefix:** The prefix name will be added on the file name of the recording file(s).

**RECORDING SETTINGS**

Destination: None

Total cycling recording size: 1000 Mbytes [200~2000000]

Size of each file for recording: 10 Mbytes

Time of each file for recording: 10 seconds

File Name Prefix:

Save Settings Don't Save Settings

SECURITY

Note: Please Format SD card before use. The entire data in the SD card will be erased after formatting.

## SD Card

Here you may browse and manage the recorded files which are stored on the SD card.

**Format SD Card:** Click this icon to automatically format the SD card and create "picture" & "video" folders.

**View Recorded Picture:** If the picture files are stored on the SD card, click on the picture folder and choose the picture file you would like to view.

**Playback Recorded Video:** If video files are stored on the SD card, click on the video folder and choose the video file you would like to view.

**Refresh:** Reloads the file and folder information from the SD card.

The screenshot shows the D-Link DCS-6314 web interface. The main content area is titled "SD CARD" and contains the following information:

SD Card: / SD Status : Ready  
Files per Page: 10 Refresh 1 of 1

Delete	File	Num of files	Size
<input type="checkbox"/>	<a href="#">dcm</a>	0	
<input type="checkbox"/>	<a href="#">Video</a>	0	
<input type="checkbox"/>	<a href="#">Picture</a>	0	
<input type="checkbox"/>	<a href="#">2011_06_22_HALF at Lights out Day</a>	1	
<input type="checkbox"/>	<a href="#">nikon001.dsc</a>		1

Format SD Card Total:15981056KB, Used:7878368KB, Free:8102688KB

OK

**Helpful Hints..**  
**Format SD Card:** Click this icon, system will automatically format SD card and create "picture" & "video" folders.  
**View recorded picture:** If SD stored recorded picture files, enter picture link and choose which picture file you desire to view. You will view picture via image viewer SW. (ie. Windows Image Viewer)  
**Playback recorded video:** If SD stored recorded video files, enter video link and choose which video file you desire to playback. Windows will guide you to open/download video file (.AVI format) so that you

## Advanced Digital Input/Output

This screen allows you to control the behavior of digital input and digital output devices. The I/O connector provides the physical interface for digital output (DO) and digital input (DI) that is used for connecting a variety of external alarm devices such as IR-Sensors and alarm relays. The digital input is used for connecting external alarm devices and once triggered images will be taken and e-mailed. After making any changes, click the **Save Settings** button to save your changes.

**Select D/I or D/O Mode:** The camera will send a signal when an event is triggered, depending upon the type of device connected to the DI circuit.

N.C. stands for **Normally Closed**. This means that the normal state of the circuit is closed. Therefore events are triggered when the device status changes to "Open."

N.O. stands for **Normally Open**. This means that the normal state of the circuit is open. Therefore events are triggered when the device status changes to "Closed."

**LED:** You may specify whether or not to illuminate the status LED on the camera.

**Video Output:** Enable/ disable the BNC terminal TV output signal.

The screenshot displays the D-Link DCS-6314 web interface. The top navigation bar includes 'LIVE VIDEO', 'SETUP', 'ADVANCED', 'MAINTENANCE', 'STATUS', and 'HELP'. The 'ADVANCED' tab is selected. On the left, a sidebar menu lists 'DI and DO', 'ICR and IR', 'HTTPS', 'Access List', and 'Logout'. The main content area is titled 'DI AND DO' and contains two sections. The first section, 'DI AND DO', explains the I/O connector and provides a 'Save Settings' and 'Don't Save Settings' button. The second section, 'DI AND DO', shows configuration for Digital Input 1 and Digital Output, both with dropdown menus set to 'N.O.' and a 'Normal Open' status. A 'Helpful Hints...' sidebar on the right provides additional information about the I/O terminal block and relay switch.

## ICR and IR

Here you can configure the ICR and IR settings. An IR(Infrared) Cut-Removable(ICR) filter can be disengaged for increased sensitivity in low light environments.

**Automatic:** The Day/Night mode is set automatically. Generally, the camera uses Day mode and switches to Night mode when needed.

**Day Mode:** Day mode enables the IR Cut Filter.

**Night Mode:** Night mode disables the IR Cut Filter.

**Schedule Mode:** Set up the Day/Night mode using a schedule. The camera will enter Day mode at the starting time and return to Night mode at the ending time.

**IR Light Control:** The camera can enable or disable the IR (infrared) light according to your preferences. This setting provides additional controls depending on your specific application.

**Off:** The IR light will always be off.

**On:** The IR light will always be on.

**Sync:** The IR light will turn on when the ICR sensor is on.

**Schedule:** The IR light will turn on or off according to the schedule that you specify below.

**D-Link**

DCS-6314 // LIVE VIDEO SETUP **ADVANCED** MAINTENANCE STATUS HELP

DI and DO  
ICR and IR  
HTTPS  
Access List  
Logout

**ICR AND IR**

An IR(Infrared) Cut-Removable(ICR) filter can be disengaged from the image path for increased sensitivity in low light environments. The ICR filter will automatically engage depending on the ambient light, allowing the camera to be effective in day/night environments.

1. Select the Day/Night from the radio button. The available options are Automatic, Schedule mode, Day mode and Night mode.
2. The default value is Automatic.

Light Sensor Sensitivity  
Light sensor sensitivity has Low, Medium, and High three different levels. You may get current camera light illumination by clicking Refresh button to set proper level of Light sensor sensitivity. For example, when level sets at High less than 30lux. camera will switch Day & Night mode to Night mode.

IR Light  
The built-in IR light illuminators will be activated automatically or manually so as to supplement the low light situation without additional equipment.

Save Settings Don't Save Settings

**ICR**

Removable IR-Cut filter trigger condition:

Automatic Sensitivity: Medium: <20lux over 30 lux Refresh

Day mode

Night mode

Schedule mode

Day mode(24hr)  
From 07 00 To 18 00

**IR LIGHT**

IR Light Control: Medium

Off

On

Sync. With ICR

Schedule

IR Light Control On(24hr)  
From 07 00 To 18 00

Save Settings Don't Save Settings

**Helpful Hints..**

**ICR and IR:**  
**Automatic:** The day/Night mode is set automatically. It is normally set in the Day mode and changes to the Night mode in a dark place.  
**Day mode:** The Day mode means disable the IR Cut Filter.  
**Night mode:** The Night mode means enable the IR Cut Filter.  
**Schedule mode:** Set the Day/Night mode using the schedule. Fill in the time so the Day/Night mode is normally set to Day mode and it enters the Day mode at the start time and returns to the Night mode at the end time.

**IR Light Control:**  
In poor light conditions, open IR Light Control to automatically turn on the light to enable you to take clear picture. The IR Light Control has 4 options: Off, On, Sync. with ICR, and Schedule. Off: This option disable the IR Light Control. On: This option automatically opens the IR Light Control to enable a camera to take clear images in poor light conditions. Sync. with ICR: In this option, the IR Light Control will open automatically and follow the ICR setting. Schedule: In this option, you have to customize the setting to set the time period you want. Please set the Start time and the End time of your chosen schedule.

**SECURITY**

# HTTPS

This page allows you to install and activate an HTTPS certificate for secure access to your camera. After making any changes, click the **Save Settings** button to save your changes.

**Enable HTTPS Secure Connection:** Enable the HTTPS service.

**Create Certificate Method:** Choose the way the certificate should be created. Three options are available:

- Create a self-signed certificate automatically
- Create a self-signed certificate manually
- Create a certificate request and install

**Status:** Displays the status of the certificate.

**Note:** The certificate cannot be removed while the HTTPS is still enabled. To remove the certificate, you must first uncheck **Enable HTTPS secure connection**.

The screenshot shows the D-Link web interface for the DCS-6314 camera. The top navigation bar includes 'LIVE VIDEO', 'SETUP', 'ADVANCED', 'MAINTENANCE', 'STATUS', and 'HELP'. The left sidebar lists 'DI and DO', 'ICR and IR', 'HTTPS', 'Access List', and 'Logout'. The main content area is titled 'HTTPS' and contains the following sections:

- HTTPS:** A message stating "To enable HTTPS, you have to create and install certificate first." with 'Save Settings' and 'Don't Save Settings' buttons.
- HTTPS:** A section with a checkbox for 'Enable HTTPS secure connection'. Below it, 'Create certificate method' options are listed: 'Create self-signed certificate automatically' (selected), 'Create self-signed certificate manually', and 'Create certificate request and install'. A 'Create certificate:' field shows 'Create' and 'Private key existed'.
- CERTIFICATE INFORMATION:** A table showing certificate details:
 

Status	Active
Country	TW
State or province	Taiwan
Locality	Taipei
Organization	D-Link Taiwan
Organization Unit	R&D Dept.
Common Name	www.dlink.com.tw

 Below the table are buttons for 'CSR Property', 'Certificate Property', and 'Remove'.

At the bottom of the main content area, there are 'Save Settings' and 'Don't Save Settings' buttons. On the right side, there is a 'Helpful Hints...' section with a note: "Enable HTTPS secure connection: allows you to enable HTTPS service. Note: 1. The certificate can't be removed while the HTTPS is still enabled. To remove the certificate you have to uncheck the 'Enable HTTPS secure connection' first."

## Access List

Here you can set access permissions for users to view your DCS-6314.

**Allow list:** The list of IP addresses that have the access right to the camera.

**Start IP address:** The starting IP Address of the devices (such as a computer) that have permission to access the video of the camera. Click **Add** to save the changes made.

**Note:** A total of seven lists can be configured for both columns.

**End IP address:** The ending IP Address of the devices (such as a computer) that have permission to access the video of the camera.

**Delete allow list:** Remove the customized setting from the Allow List.

**Deny list:** The list of IP addresses that have no access rights to the camera.

**Delete deny list:** Remove the customized setting from the Delete List.

### For example:

When the range of the Allowed List is set from 1.1.1.0 to 192.255.255.255 and the range of the Denied List is set from 1.1.1.0 to 170.255.255.255. Only users with IPs located between 171.0.0.0 and 192.255.255.255 can access the Network Camera.

**D-Link**

DCS-6314 // LIVE VIDEO SETUP **ADVANCED** MAINTENANCE STATUS HELP

DI and DO  
ICR and IR  
HTTPS  
Access List  
Logout

**ACCESS LIST**  
Here you can set access permissions for users to view your IP camera.

**ALLOW LIST**

Start IP address   
End IP address    
Delete allow list

**DENY LIST**

Start IP address   
End IP address    
Delete deny list

**Helpful Hints...**

**Allow List:**  
"Start IP Address"  
The starting IP Address of the devices (such as a computer) that have permission to access the video of the IP camera.  
"End IP Address"  
The ending IP Address of the devices (such as a computer) that have permission to access the video of the IP camera.  
"Delete Allow List"  
Remove the customized setting from the Allow List.

**Deny List:**  
"Start IP Address"  
The starting IP Address of the devices (such as a computer) that don't have permission to

# Maintenance

## Device Management

In this section you may change settings for the administration of the camera. You can also add or delete users, as well as enable or disable certain functions such as the on screen display or camera LED's.

**Admin Password Setting:** Set a new password for the administrator's account.

**Add User Account:** Add new user account.

**User Name:** The user name for the new account.

**Password:** The password for the new account.

**User List:** All the existing user accounts will be displayed here. You may delete accounts included in the list, but you may want to reserve at least one as a guest account.

**Camera Name:** Create a unique name for your camera that will be added to the file name prefix when creating a snapshot or a video clip.

**Enable OSD:** Select this option to enable the On-Screen Display feature for your camera.

**Label:** Enter a label for the camera, which will be shown on the OSD when it is enabled.

**Show Time:** Select this option to enable the time-stamp display on the video screen.

**LED:** Select whether to turn the camera LED on or off.

**D-Link**

DCS-6314 // LIVE VIDEO SETUP ADVANCED MAINTENANCE STATUS HELP

Admin  
System  
Firmware Upgrade  
Logout

**ADMIN**

Here you can change the administrator's password for your IP camera as well as add and/or delete user account(s). You can configure the information, such as IP camera's name and time via this page. You can also enable the OSD (On-Screen Display) feature in order to display the IP camera name and time stamp for your video recordings.

**ADMIN PASSWORD SETTING**

New Password  63 characters maximum  
Retype Password

**ADD USER ACCOUNT**

User Name  20 users maximum  
New Password  63 characters maximum  
Retype Password

**USER LIST**

User Name  -- User list --

**DEVICE SETTING**

IP camera Name  DCS-6314 63 characters maximum  
 Enable OSD  
Label  DCS-6314 30 characters maximum  
Show time

**LED**

LED  On  Off

**Helpful Hints...**

Enabling OSD, the IP camera name and time will be displayed on the video screen for the user.

For security purposes, it is recommended that you change the password for your administrator account. Be sure to write down the new password to avoid having to reset the IP camera in the event that it is forgotten.

**LED:** In the near panel of your camera there is a LED beside the network adapter. ON: The LED will flash a light to indicate if the network is working or not. OFF: No light will show, forth option is turn off.

**SECURITY**



## System

In this section, you may backup, restore and reset the camera configuration, or reboot the camera.

**Save To Local Hard Drive:** You may save your current camera configuration as a file on your computer.

**Load From Local Hard Drive:** Locate a pre-saved configuration by clicking **Browse** and then restore the pre-defined settings to your camera by clicking **Load Configuration**.

**Restore to Factory Default:** You may reset your camera and restore the factory settings by clicking **Restore Factory Defaults**.

**Reboot Device:** This will restart your camera.

The screenshot displays the D-Link web interface for the DCS-6314 camera. The top navigation bar includes the D-Link logo and tabs for LIVE VIDEO, SETUP, ADVANCED, MAINTENANCE, STATUS, and HELP. The left sidebar contains links for Admin, System, Firmware Upgrade, and Logout. The main content area is titled 'SYSTEM' and contains the following options:

- Save To Local Hard Drive:** Includes a 'Save Configuration' button.
- Load From Local Hard Drive:** Includes a 'Choose File' button (with 'No file chosen' text) and a 'Load Configuration' button.
- Restore To Factory Defaults:** Includes a 'Restore Factory Defaults' button.
- Reboot Device:** Includes a 'Reboot Device' button.

A 'Helpful Hints...' sidebar on the right provides instructions: 'After the factory's default settings have been restored, use the installation wizard software provided with your IP camera to search and connect to the IP camera.'

## Firmware Upgrade

The camera's current firmware version will be displayed on this screen. You may visit the D-Link Support Website to check for the latest available firmware version.

To upgrade the firmware on your DCS-6314, please download and save the latest firmware version from the D-Link Support Page to your local hard drive. Locate the file on your local hard drive by clicking the **Browse** button. Select the file and click the **Upload** button to start upgrading the firmware.

**Current Firmware Version:** Displays the detected firmware version.

**Current Product Name:** Displays the camera model name.

**File Path:** Locate the file (upgraded firmware) on your hard drive by clicking **Browse**.

**Upload:** Uploads the new firmware to your camera.

The screenshot shows the D-Link web interface for the DCS-6314 camera. The top navigation bar includes 'LIVE VIDEO', 'SETUP', 'ADVANCED', 'MAINTENANCE', 'STATUS', and 'HELP'. The left sidebar has 'Admin', 'System', 'Firmware Upgrade', and 'Logout' options. The main content area is titled 'FIRMWARE UPGRADE' and contains the following text:

**FIRMWARE UPGRADE**

A new firmware upgrade may be available for your IP camera. It is recommended to keep your IP camera firmware up-to-date to maintain and improve the functionality and performance of your internet IP camera. Click here [D-Link Support Page](#) to check for the latest firmware version available.

To upgrade the firmware on your IP camera, please download and save the latest firmware version from the D-Link Support Page to your local hard drive. Locate the file on your local hard drive by clicking the Browse button. Once you have found and opened the file using the browse button, click the "Upload" button to start the firmware upgrade.

**FIRMWARE INFORMATION**

Current Firmware Version:	0.01.00
Current Product Name:	DCS-6314

**FIRMWARE UPGRADE**

File Path:  No file chosen

**Helpful Hints..**

Firmware upgrade are released periodically to improve the functionality of your IP camera and also to add new features. If you run into a problem with a specific feature of the IP camera, check our support site by clicking [here](#) to check for an upgrade and see if updated firmware is available for your IP camera.

# Status Device Info

This page displays detailed information about your device and network connection.

The screenshot shows the D-Link web interface for the DCS-6314 device. The top navigation bar includes 'LIVE VIDEO', 'SETUP', 'ADVANCED', 'MAINTENANCE', 'STATUS', and 'HELP'. The 'STATUS' tab is active, and the 'DEVICE INFO' sub-tab is selected. The main content area is titled 'DEVICE INFO' and contains a message: 'All of your network connection details are displayed on this page. The firmware version is also displayed here.' Below this is an 'INFORMATION' table with the following data:

INFORMATION	
IP camera Name	DCS-6314
Time & Date	Wed Mar 20 11:00:57 2013
Firmware Version	0.01.00
MAC Address	0A:34:CA:6A:CA:0B
IP Address	192.168.0.100
IP Subnet Mask	255.255.255.0
Default Gateway	192.168.0.1
Primary DNS	192.168.0.1
Secondary DNS	0.0.0.0
PPPoE	Disable
DDNS	Disable

On the right side of the interface, there is a 'Helpful Hints...' section with the text: 'This page displays all the information about the IP camera and network settings.'

## Logs

This page displays the log information of your camera. You may download the information by clicking **Download**. You may also click **Clear** to delete the saved log information.

**D-Link**

DCS-6314 // LIVE VIDEO SETUP ADVANCED MAINTENANCE STATUS HELP

Device Info  
Log  
Logout

**SYSTEM LOG**  
The system log records IP camera events that have occurred.

**CURRENT LOG**

1. 2013-03-20 11:00:23 NETWORK RECONNECT
2. 2013-03-20 11:00:18 Someone Create Certificate
3. 2013-03-20 11:00:17 NETWORK LOSS
4. 2013-03-20 11:00:17 NETWORK RECONNECT
5. 2013-03-20 11:00:07 NETWORK LOSS
6. 2013-03-20 11:00:06 IP CAMERA ACQUIRE DHCP IP 192.168.0.100
7. 2013-03-20 11:00:05 NETWORK RECONNECT
8. 2013-03-20 11:00:04 NETWORK LOSS
9. 2013-03-20 10:57:14 IP CAMERA ACQUIRE DHCP IP 192.168.0.100
10. 2013-03-20 10:57:14 NETWORK RECONNECT
11. 2013-03-20 10:57:12 NETWORK LOSS
12. 2013-03-20 10:55:36 admin LOGIN OK FROM 192.168.0.2
13. 2013-03-20 10:47:10 admin FROM 192.168.0.2 SET VIDEO CODEC Need Reset
14. 2013-03-20 10:47:10 admin FROM 192.168.0.2 SET PROFILE 1 Viewer window area 640x360
15. 2013-03-20 10:47:10 admin FROM 192.168.0.2 SET PROFILE 1 Frame Size 640x360
16. 2013-03-20 10:44:28 IP CAMERA ACQUIRE DHCP IP 192.168.0.100
17. 2013-03-20 10:44:28 NETWORK RECONNECT
18. 2013-03-20 10:44:24 NETWORK LOSS
19. 2013-03-20 10:42:20 IP CAMERA ACQUIRE DHCP IP 192.168.0.100
20. 2013-03-20 10:42:19 NETWORK RECONNECT

First Page Previous 20 Next 20  
Clear Download

**Helpful Hints..**  
You can save the log to your local hard IP camera by clicking the Download button, and you can clear the log by clicking on the Clear button.

# Help

This page provides helpful information regarding camera operation.

**D-Link**

DCS-6314 // LIVE VIDEO SETUP ADVANCED MAINTENANCE STATUS HELP

Help  
Logout

**HELP**

- [LIVE VIDEO](#)
- [SETUP](#)
- [MAINTENANCE](#)
- [ADVANCED](#)
- [STATUS](#)

**LIVE VIDEO**

- [Camera](#)

**SETUP**

- [Setup Wizard](#)
- [Network Setup](#)
- [Dynamic DNS](#)
- [Image Setup](#)
- [Audio and Video](#)
- [Preset](#)
- [Motion Detection](#)
- [Time and Date](#)
- [Event Setup](#)
- [SD Card](#)

**ADVANCED**

- [DI and DO](#)
- [ICR and IR](#)
- [HTTPS](#)
- [Access List](#)

**MAINTENANCE**

- [Admin](#)
- [System](#)
- [Firmware Upgrade](#)

**STATUS**

- [Device Info](#)
- [Log](#)

**SECURITY**

# DI/DO Specifications

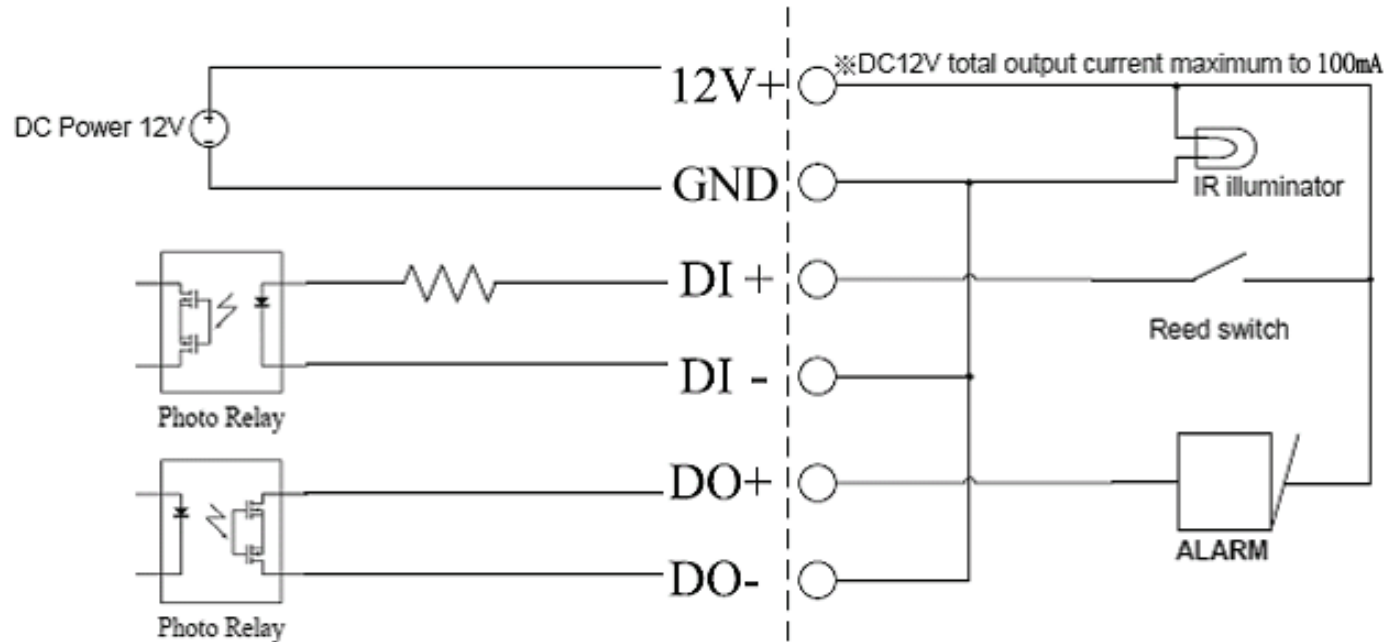



# Technical Specifications

<b>Camera</b>	<b>Camera Hardware Profile</b>	<ul style="list-style-type: none"> <li>• 1/2.8" 2 Megapixel progressive CMOS sensor</li> <li>• 15 meter IR illumination distance</li> <li>• Minimum illumination 0.2 Lux / F1.4 Color mode</li> <li>• Minimum illumination 0.05 Lux / F1.4 Black and White mode</li> <li>• Minimum illumination 0 Lux Black and White mode with IR LED on</li> <li>• Removable (ICR) Filter module</li> </ul>	<ul style="list-style-type: none"> <li>• 2.8 to 12mm variable focal lens</li> <li>• Aperture F1.4</li> <li>• Angle of view (16:9)               <ul style="list-style-type: none"> <li>• (H) 96.5° ~ 31.2°</li> <li>• (V) 64.5° ~ 17.8°</li> <li>• (D) 117.5° ~ 36.8°</li> </ul> </li> </ul>
	<b>Camera Housing</b>	<ul style="list-style-type: none"> <li>• IP68 compliant weatherproof housing</li> <li>• IK-10 compliant vandal-proof housing</li> </ul>	<ul style="list-style-type: none"> <li>• Included weather shield</li> </ul>
	<b>Image Features</b>	<ul style="list-style-type: none"> <li>• Configurable image size, quality, frame rate, and bit rate</li> <li>• Time stamp and text overlays</li> <li>• Configurable motion detection windows</li> </ul>	<ul style="list-style-type: none"> <li>• Configurable privacy mask zones</li> <li>• Configurable exposure time, brightness, saturation, contrast, contrast, sharpness.</li> </ul>
	<b>Video Compression</b>	<ul style="list-style-type: none"> <li>• Simultaneous H.264/MPEG-4/MJPEG format compression</li> <li>• H.264/MPEG-4 multicast streaming</li> </ul>	<ul style="list-style-type: none"> <li>• JPEG for still images</li> </ul>
	<b>Video Resolution</b>	<ul style="list-style-type: none"> <li>• 16:9 - 1920 x 1080, 1280 x 720, 800 x 450, 640 x 360, 480 x 270, 320 x 176, 176 x 144 up to 30 fps</li> </ul>	<ul style="list-style-type: none"> <li>• 4:3 - 1440 x 1080, 1280 x 960, 1024 x 768, 800 x 600, 640 x 480, 320 x 240, 176 x 144 up to 30 fps</li> </ul>
	<b>Audio Support</b>	<ul style="list-style-type: none"> <li>• G.726</li> </ul>	<ul style="list-style-type: none"> <li>• G.711</li> </ul>
	<b>External Device Interface</b>	<ul style="list-style-type: none"> <li>• 10/100 BASE-TX Ethernet port with PoE</li> <li>• 1 DI / 1 DO</li> <li>• DC12V, 100 mA Output</li> </ul>	<ul style="list-style-type: none"> <li>• micro SD/SDHC card Slot</li> <li>• Audio input / output</li> </ul>
<b>Network</b>	<b>Network Protocols</b>	<ul style="list-style-type: none"> <li>• IPv6</li> <li>• IPv4</li> <li>• TCP/IP</li> <li>• UDP</li> <li>• ICMP</li> <li>• DHCP client</li> <li>• NTP client (D-Link)</li> <li>• DNS client</li> <li>• DDNS client (D-Link)</li> <li>• SMTP client</li> <li>• FTP client</li> </ul>	<ul style="list-style-type: none"> <li>• HTTP / HTTPS</li> <li>• Samba client</li> <li>• PPPoE</li> <li>• UPnP port forwarding</li> <li>• RTP / RTSP / RTCP</li> <li>• IP filtering</li> <li>• QoS</li> <li>• CoS</li> <li>• Multicast</li> <li>• ONVIF compliant</li> </ul>
	<b>Security</b>	<ul style="list-style-type: none"> <li>• Administrator and user group protection</li> <li>• Password authentication</li> </ul>	<ul style="list-style-type: none"> <li>• HTTP and RTSP digest encryption</li> </ul>

## Appendix A: Technical Specifications

<b>System Management</b>	System Requirements for Web Interface	<ul style="list-style-type: none"> <li>• Browser: Internet Explorer, Firefox, Chrome, Safari</li> </ul>	
	Event Management	<ul style="list-style-type: none"> <li>• Motion detection</li> <li>• Event notification and uploading of snapshots/video clips via e-mail or FTP</li> </ul>	<ul style="list-style-type: none"> <li>• Supports multiple SMTP and FTP servers</li> <li>• Multiple event notifications</li> <li>• Multiple recording methods for easy backup</li> </ul>
	Remote Management	<ul style="list-style-type: none"> <li>• Take snapshots/video clips and save to local hard drive or NAS via web browser</li> </ul>	<ul style="list-style-type: none"> <li>• Configuration interface accessible via web browser</li> </ul>
	OS Support	<ul style="list-style-type: none"> <li>• Windows 2000/XP/Vista/Windows 7/8</li> </ul>	
	D-ViewCam™ System Requirements	<ul style="list-style-type: none"> <li>• Operating System: Microsoft Windows 7/Vista/XP</li> <li>• Web Browser: Internet Explorer 7 or higher</li> </ul>	<ul style="list-style-type: none"> <li>• Protocol: Standard TCP/IP</li> </ul>
	D-ViewCam™ Software Functions	<ul style="list-style-type: none"> <li>• Remote management/control of up to 32 cameras</li> <li>• Viewing of up to 32 cameras on one screen</li> </ul>	<ul style="list-style-type: none"> <li>• Supports all management functions provided in web interface</li> <li>• Scheduled motion triggered, or manual recording options</li> </ul>
<b>General</b>	Weight	<ul style="list-style-type: none"> <li>• 1112g (with weathershield)</li> </ul>	
	External Power Adapter	<ul style="list-style-type: none"> <li>• Input: 100~240 V AC , 50/60 Hz</li> </ul>	<ul style="list-style-type: none"> <li>• Output: 12 V DC 1.25 A</li> </ul>
	Power Consumption	<ul style="list-style-type: none"> <li>• 10 +-5% Watt</li> </ul>	
	Temperature	<ul style="list-style-type: none"> <li>• Operating: -30 to 50 °C (-22 to 122 °F)</li> </ul>	<ul style="list-style-type: none"> <li>• Storage: -20° to 70° C (-4° to 158° F)</li> </ul>
	Humidity	<ul style="list-style-type: none"> <li>• Operating: 20% to 80% non-condensing</li> </ul>	<ul style="list-style-type: none"> <li>• Storage: 5% to 95% non-condensing</li> </ul>
	Certifications	<ul style="list-style-type: none"> <li>• CE</li> <li>• CE LVD</li> </ul>	<ul style="list-style-type: none"> <li>• FCC</li> <li>• C-Tick</li> </ul>

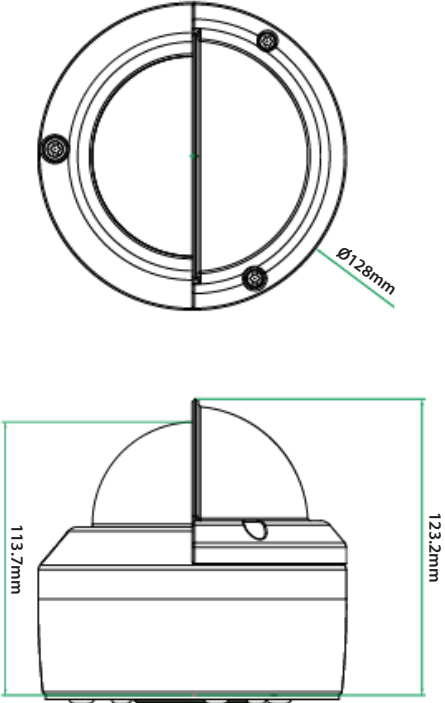

<p><b>Dimensions</b></p>			
<p><b>Order Information</b></p>	<p><b>Part Number</b></p>	<p><b>Description</b></p>	
<p><b>Optional Accessories</b></p>	<p>DCS-34-2</p>		<p>Pendant Mount 201 x 150 mm (7.9 x 5.9 inches), 665 grams (1.45 lbs)</p>
	<p>DCS-34-3</p>		<p>Bent Arm Mount 253 x 150 mm (9.96 x 5.9 inches), 770 grams (1.7 lbs)</p>