

# User's Guide

Version 2.02

ANT24-Series

ANT70-Series

## D-Link Antenna Kits

## D-Link Antenna-kit Installation Guide

### Step 1

Remove the default antenna.



### Note:

When install the surge protector between cables, wrap the connectors as well. The lightning protection adaptor for grounding the antenna.



### Step 2

Connect the extension cable/antenna onto the external connector on device.



### Step 3 (If needed)

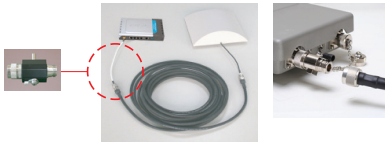

Install the surge protector. (You can install with optional ANT24 series low loss cables)

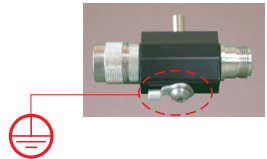

With Surge protector (ANT24-SP) adaptor on an outdoor serial is attached to the lightning protection system (ground) of the building. All devices downstream are then protected by the ground from lightning strikes. It can protect your sensitive WLAN equipments from high voltage surges caused by discharge and transients at the antennas. It will be integrated in the cabling system between the antenna and the coax-cable and must have direct ground contact.

# D-Link Antenna-kit Installation Guide

ANT24-SP Surge protector  
Installation guide  
for outdoor antenna-kit

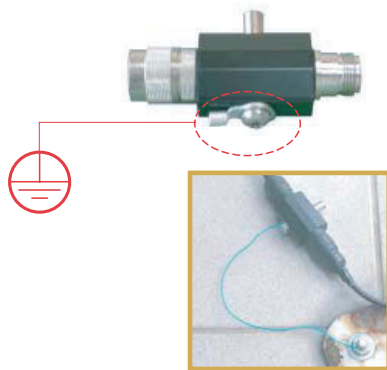

**Step 1**  
loosen the screw from the surge protector.

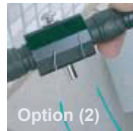

**Step 2**  
get a normal conductive copper wire with 2 sides stripped long enough to be conductive, these wires can lead high voltage surges into the grounding.

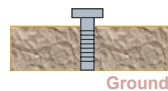

**Step 3**  
find a conductive material nearby the antenna installation sites, connect another end of the wire into position, there are several options:

- (1) Use a long screw to stick into the ground tightly, connect another wire onto.
- (2) fix or solder another end of wire onto a steel material/ bar under steel construction, such as wall for buildings, railings or other conductive materials which set up from the ground.

**Remark:**

- (1) for the ground screw you use, we suggest the longer (deeper into ground) the better performance it has.
- (2) please use a copper wire with diameter at least from 2.0mm, the thicker the diameter, the higher voltage it can sustain.

# Regulations

D-Link WLAN Antenna-kit

Extended range differentiation for FCC/ CE regulated regions

**CE ETSI EN 300 328 regulated regions (European countries)**

Based on ( ETSI EN 300 328 ), EIRP (Emitted Isotropic Radiated Power) limited within **20dB**.

Therefore, the extended range might be shorter than FCC-regulated antennas.

**FCC regulated regions (US, Canada...)**

Using the same antenna-kit in FCC-regulated regions, the extended range might be **LONGER** than CE-regulated antennas due to **HIGHER** output power allowance !

Please add some sentences in P4 as below

“Use of high gain antennas need careful planning to conform with EU regulations and extra consideration to avoid causing a potential health hazard, Please always seek qualified professional installer in all cases. “

“Outdoor Installations

Although D-Link offers a range of quality outdoor antennas, please note these devices are designed only to be installed by a professional as there are EU regulations that need to be considered. Cable lengths and quality will affect the antenna gain dramatically.”

**EIRP limitaton:**

		2.4GHz-2.5GHz	5.15GHz-5.35GHz	5.47-5.725	5.75GHz-5.875GHz
ETSI	point to multi-point	20dBm ave. 23dBm peak.	23dBm	30dBm	X
	point to point				
FCC	point to multi-point	36dBm	23dBm	X	36dBm
	point to point	30+(antenna gain ) dBm then above 30dBm, one dB output power reduced, then 3dB antenna gain increased			30+23(antenna gain) then above 30dBm, one dB output power reduced, then 3dB antenna gain increased

For outdoor use **EIRP = Effective,Isotropic Radiated Power**  
= Device Output Power + Antenna Gain - Cable Loss

## Cable Loss

Model	Cable Type	Length	Interface	Cable loss (dB) @ 2.4GHz	Cable loss(dB) @5GHz
ANT24-CB03N	LMR400	3m	N plug to N jack	1	1.75
ANT24-CB06N	LMR400	6m	N plug to N jack	1.85	2.7
ANT24-CB09N	LMR400	9m	N plug to N jack	2.6	3.8
ANT24-ODU03M	LMR200	0.3m	RP N plug to N plug	0.6	1.15
ANT24-ODU1M	LMR400	1m	RP N plug to N plug	0.6	1.15
ANT24-ODU3M	LMR400	3m	RP N plug to N plug	1	1.75
ANT24-DLK3M	LMR200	3m	RP SMA plug to N plug	2	3.45

Note:

- The loss value includes two connectors ( around 0.3~0.4dB @ 2.4GHz, 0.39~0.52dB@5GHz).
- The longer cable you use, the more attenuation it causes, therefore, the extended range might be shorten then a normal link with default cables.
- To comply with EU regulation, please use longer cables which can cause enough attenuation value.
- For more detail of connectors type, please refer to the appendix page.(P.34)

# D-Link ANT24-0401 Ceiling Mount Antenna

## Electrical specification

Frequency band	2400-2500MHz
Antenna gain	2.5 ~ 3.7 dBi
VSWR	2.0 max
Polarization	Linear vertical
HPBW / H-plane	360
HPBW / E-plane	58°~75°
Impedence	50 Ohms
Dimensions	∅132x42 mm
Weight	110g without joint

## Environmental & Mechanical Characteristics

Temperature	-10°C to 55°C
Humidity	100% @ 25°C
Lightning protection	DC ground
Radome color	white
Radome material	ABS
Weight	100gw
Dimensions	∅132 x 42 mm

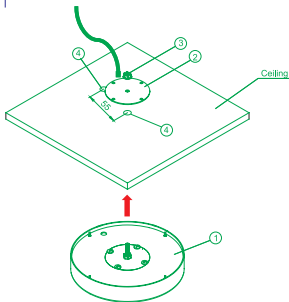

### Installation Note:

1. Carefully remove the antenna from the package.
2. Take out the Washer ( 1 pcs ) from the package
3. Take out the Flange washer ( 1 pcs ) as well.
4. Drill 2 holes through the ceiling board, one to fix the antenna main body with washer, another for the antenna SMA connector linked onto extension cable which is included within the package.

### Package Contents:

- ANT24-0401 Antenna
- Extension Cable ( 2M )
- Mounting Kit
- Quick Installation Guide

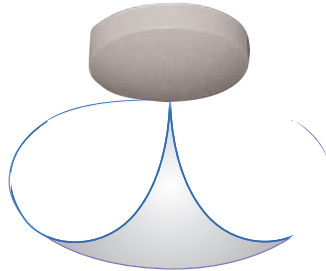
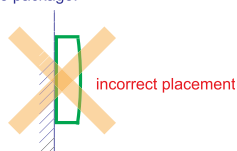

Horizontal coverage



Overlook

Vertical coverage

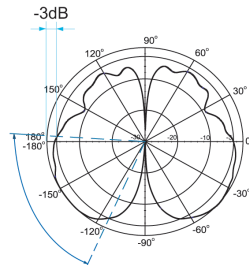

Vertical Pattern@2.45 GHz

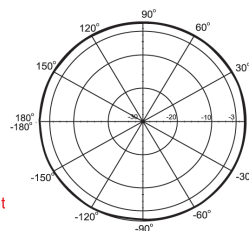

Horizontal Pattern @2.45 GHz

## D-Link ANT24-0500 Indoor/Outdoor Omni-Directional Antenna

### Electrical specification

Frequency band	2400-2500MHz
Antenna gain	5.0 dBi
VSWR	2.0 max
Polarization	Linear vertical
HPBW / H-plane	360
HPBW / E-plane	32°
Impedence	50 Ohms
Dimensions LxWxH	Ø19x330mm
Weight	180g without joint

### Environmental & Mechanical Characteristics

Survival wind speed	180 km/hr
Temperature	-40°C to +80°C
Humidity	100% @ 25°C
Lightning protection	DC ground
Radome color	Gray-white
Radome material	Fiberglass
Radiator material	Micro stripe line
Weight	0.8kgw
Dimensions	330 x ø19 mm

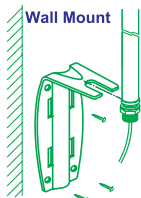
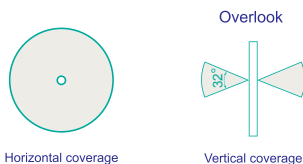
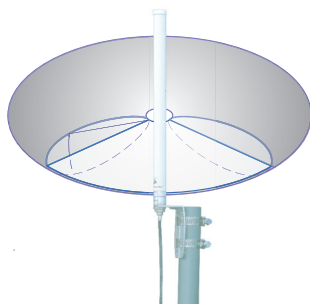

### Pole Mount

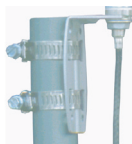

### Installation Note:

1. use L-type mounting to fix with antenna
2. use 4 plastic anchor with (4) screws to install the antenna onto the wall.
3. use band clamp ( 2pcs ) to fix the antenna on the pole.

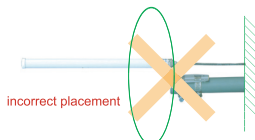

### Package Contents:

- ANT24-0500 Antenna
- Extension Cable ( 3m )
- Mounting Kit
- Quick Installation Guide

H-plane Co-polarization Pattern

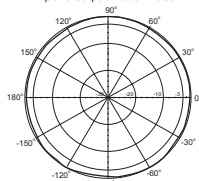

V-plane Co-polarization Pattern

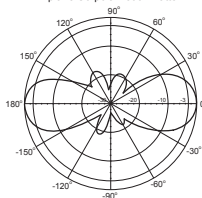

### ⚠ CAUTION:

Please always place the antenna vertically to the horizontal surface, not recommend to mount the antenna perpendicular to walls.

# D-Link ANT24-0501

## Indoor Omni-Directional Antenna

### Electrical specification

Frequency Range	2400-2500MHz
Impedance	50Ω Normal
VSWR	1.92 Max
Return Loss	-10 dB Maximum
Antenna Structure	Helix antenna
Peak Gain ( w/o cable loss)	5dBi
Admitted Power	1 W
Cable loss( 1.5m)	2.1dB@2.45GHz
E-Plane	36 deg.
H-Plane	360 deg.

### Physical Properties

Cable	RG-178 50Ω
Cable length	1.5 M
Cable color	Gray
Connector	Reverse SMA plug
Antenna Material	ABS, ABS+PC
Operating Temp	-20°C ~ +65°C
Storage Temp	-30°C ~ +75°C
Color	Antenna: Metallic gray and silver Base: Metallic gray

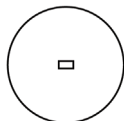

Horizontal coverage

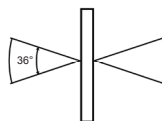

Vertical coverage

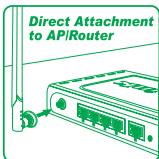
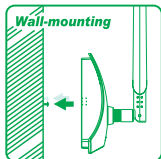
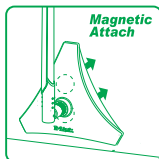
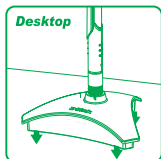

### Package Contents

- One ANT24-0501 2.4GHz indoor 5dBi omni-directional Antenna with 1.5M extension cable and RP-SMA Jack connector
- One RP-SMA/ RP-TNC adaptor
- One registration card and international office guide
- Mounting kit includes:
  - Two Crews
  - Two plastic fixings
  - One sticker

Far-field amplitude of D-link-5dBi-H-1020.nsi

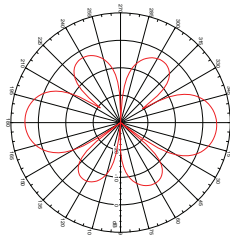

Far-field amplitude of D-link-5dBi-v-1020.nsi

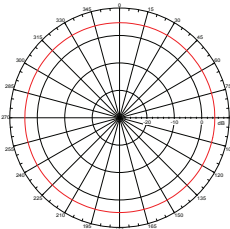

# D-Link ANT24-0501C Indoor Omni-Directional Antenna

## Electrical specification

Frequency Range	2400-2500MHz
Impedance	50Ω Normal
VSWR	1.92 Max
Peak Gain	5dBi
Admitted Power	1 W
E-Plane	36 deg.
H-Plane	360 deg.

## Physical Properties

Connector	Reverse SMA plug
Antenna Material	ABS, ABS+PC
Operating Temp	-20°C ~ +65°C
Storage Temp	-30°C ~ +75°C
Color	Antenna: Metallic gray and silver

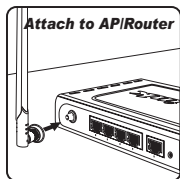

## Package Contents

- One ANT24-0501C 2.4GHz 5dBi indoor omni-directional antenna with a RP-SMA plug connector
- One RP SMA/ RP TNC adapter
- One registration card and company contact guide

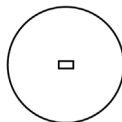

Horizontal coverage

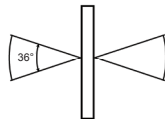

Vertical coverage

Far-field amplitude of D-link-5dBi-Ha-1020.nsi

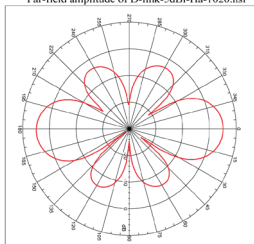

Far-field amplitude of D-link-5dBi-va-1020.nsi

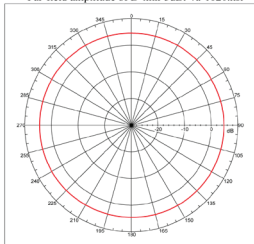



# D-Link DWL-50AT Indoor Omni-Directional Antenna

## Electrical specification

Frequency band	2400-2500MHz
Antenna gain	5.0dBi Typical
VSWR	2.0:1 Max.
Polarization	Linear
HPBW / H-plane	360°
HPBW / E-plane	30 degree
Impedence	50 Ohms nominal
Dimensions HxWxD	197 mm(length)
Weight	29.5gw



## Installation:

1. Remove the original antenna from your wireless device.
2. Screw the DWL-50AT RP- SMA connector into your wireless device.
3. Adjust the antenna to the suitable direction for extending the wireless coverage area.

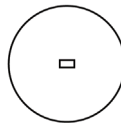

Horizontal coverage

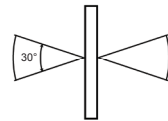

Vertical coverage

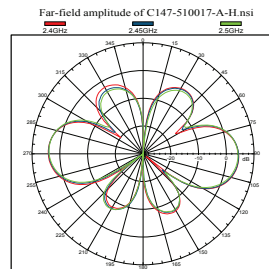
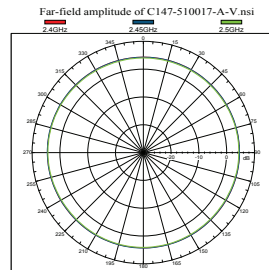

## D-Link DWL-R60AT Indoor Directional Antenna

### Electrical specification

Frequency band	2400-2500MHz
Antenna gain	6.0dBi Typical
VSWR	2.0:1 Max.
Polarization	Linear
HPBW / H-plane	70°
HPBW / E-plane	85°
Impedence	50 Ohms nominal
Dimensions HxWxD	80x85x12.8 mm
Weight	75gw

Remove one default antenna from the wireless device and start to assemble!



### Installation:

1. Remove the original antenna from your wireless device.
2. Screw the DWL-R60AT RP-SMA connector into your wireless device.
3. Adjust the antenna to the suitable direction for extending the wireless coverage area.

### Package Contents:

- DWL-R60AT Antenna
- Quick Installation Guide

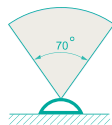

Horizontal coverage

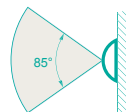

Vertical coverage

Test Mode: E Plane

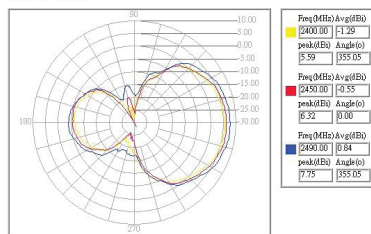

Test Mode: H Plane

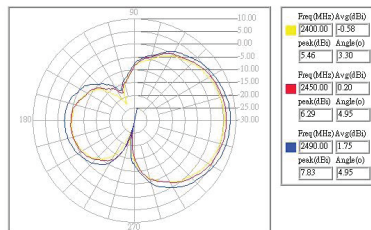

# D-Link ANT24-0600

## Indoor Directional Antenna

### Electrical specification

Frequency Range	2400~2500MHz
Impedance	50Ω Normal
VSWR	1.92 Max
Return Loss	-10 dB Maximum
Antenna Structure	Patch antenna
Peak Gain ( w/o cable loss)	6.0 dBi @ 2.45GHz ( typical)
Admitted Power	1 W
Cable loss( 1.5m)	2.1dB@2.45GHz
E-Plane	68°
H-Plane	80°

### Physical Properties

Cable	Filotex 50Ω
Antenna Cover	ABS
Antenna Base	PC
Operating Temp	-20°C ~ +65°C
Storage Temp	-30°C ~ +75°C
Color	White

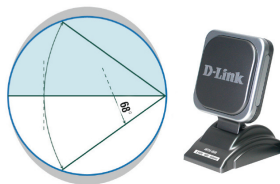

OVERLOOK

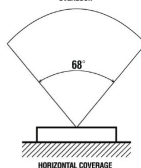

HORIZONTAL COVERAGE

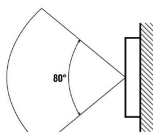

VERTICAL COVERAGE

### Desktop

#### Magnetic Attach



### Wall Mounting



### Package Contents

- One ANT24-0600 2.4GHz indoor 6dBi directional Antenna with 1.5 Filotex cable and RP-SMA Jack connector
- One RP-SMA/ RP-TNC adaptor
- One User's QIG
- Two Crews
- Two plastic fixings
- One sticker

Far-field amplitude of D-Link 6dBi H04.nsi

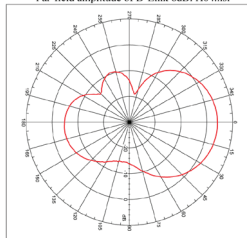

Far-field amplitude of D-Link 6dBi V04.nsi

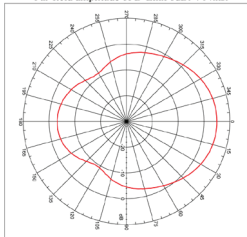

# D-Link ANT24-0700 Indoor Omni-Directional Antenna

## Electrical specification

Frequency Range	2400-2500MHz
Impedance	50Ω Normal
VSWR	1.92 Max
Return Loss	-10 dB Maximum
Antenna Structure	Helix antenna
Peak Gain ( w/o cable loss)	7dBi
Admitted Power	1 W
Cable loss( 1.5m)	2.1dB@2.45GHz
E-Plane	24 deg.
H-Plane	360 deg.

## Physical Properties

Cable	RG-178 50Ω
Cable length	1.5 M
Cable color	Gray
Connector	Reverse SMA plug
Antenna Material	ABS, ABS+PC
Operating Temp	-20°C ~ +65°C
Storage Temp	-30°C ~ +75°C
Color	Antenna: Metallic gray and silver Base: Metallic gray

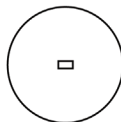

Horizontal coverage

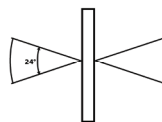

Vertical coverage

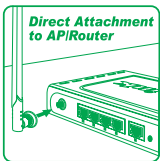
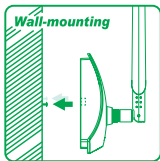
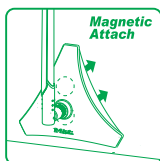
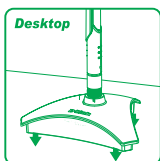

## Package Contents

- D-Link ANT24-0700 2.4GHz Omni-Directional Indoor Antenna
- SMA to TNC Adapter
- Magnetic Base with 1.5m Extension Cable
- Mounting Kit
- Installation Guide

Far-field amplitude of D-link-7dBi-H1-1020.nsi

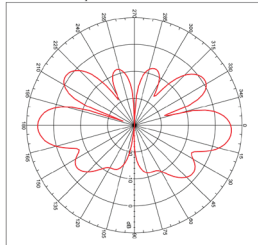

Far-field amplitude of D-link-7dBi-v-1020.nsi

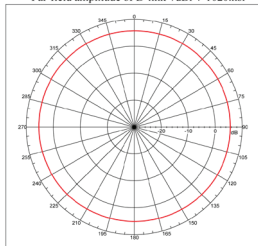

# D-Link ANT24-0700C

## Indoor Omni-Directional Antenna

### Electrical specification

Frequency Range	2400~2500MHz
Impedance	50Ω Normal
VSWR	1.92 Max
Return Loss	10 dB Maximum
Antenna Structure	Helix antenna
Peak Gain ( w/o cable loss)	7dBi
Admitted Power	1 W
Cable loss( 1.5m)	2.1dB@2.45GHz
E-Plane	24 deg.
H-Plane	360 deg.

### Physical Properties

Cable	RG-178 50Ω
Cable length	1.5 M
Cable color	Gray
Connector	Reverse SMA plug
Antenna Material	ABS, ABS+PC
Operating Temp	-20°C ~ +65°C
Storage Temp	-30°C ~ +75°C
Color	Antenna: Metallic gray and silver Base: Metallic gray

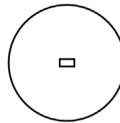

Horizontal coverage

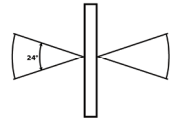

Vertical coverage

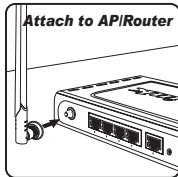

### Package Contents

- One ANT24-0700C 2.4GHz 7dBi indoor omni-directional antenna with a RP-SMA plug connector
- One RP SMA/ RP TNC adapter
- One registration card and company contact guide

Far-field amplitude of D-link-7dBi-H1-1020.msi

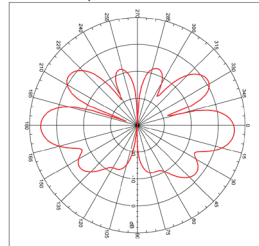

Far-field amplitude of D-link-7dBi-v1-1020.msi

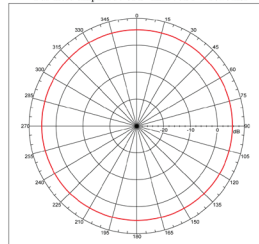

# D-Link ANT24-0800 Indoor/Outdoor Omni-Directional Antenna

## Electrical specification

Frequency band	2400-2500MHz
Antenna gain	8.0 dBi
VSWR	2.0 max
Polarization	Linear vertical
HPBW / H-plane	360°
HPBW / E-plane	15°
Impedence	50 Ohms
Dimensions LxWxH	∅19×520mm
Weight	340g without joint

## Environmental & Mechanical Characteristics

Remove one default antenna from the wireless device and start to assemble!

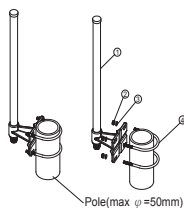

1. Antenna body
2. M5-0.8 nut
3. M5 Washer
4. M5 U-Type Screw
5. Screw
6. Anchor

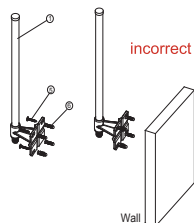

incorrect placement

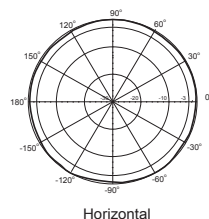
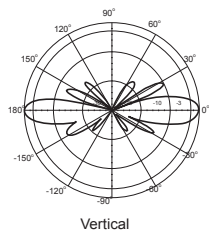
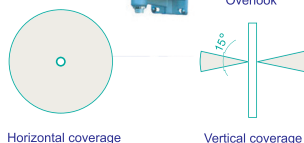
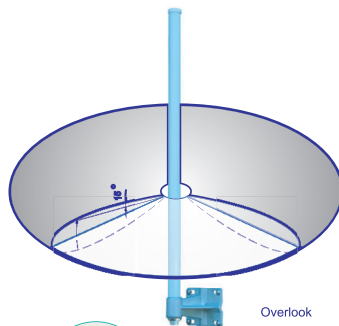
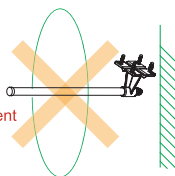

## Package Contents:

- ANT24-0800 Antenna
- Extension Cable (50cm)
- Mounting Kit
- Surge Protector
- Water-proof tape
- Quick Installation Guide

## ⚠ CAUTION:

Please always place the antenna vertically to the horizontal surface, not recommend to mount the antenna perpendicular to the wall.

# D-Link ANT24-0801 Indoor/Outdoor Directional Panel Antenna

## Electrical specification

Frequency	2400-2500MHz
Gain	8.5 dBi
VSWR	1.5 : 1 Max
Polarization	Linear, vertical
HPBW / horizontal	65°
HPBW / vertical	65°
Front to back ratio	15 dB
Power handling	50 W (cm)
Impedance	50 Ohms
Connector	N - female

## Environmental & Mechanical Characteristics

Survival wind speed	216 km/hr
Temperature	-40°C to +80°C
Humidity	95% @ 55 C°
Lightning protection	DC ground
Radome color	Gray-white
Radome material	ABS, UV resistant
Housing material	AL6063
Weight	0.3 kgw
Dimensions	120 x 120 x 43 mm

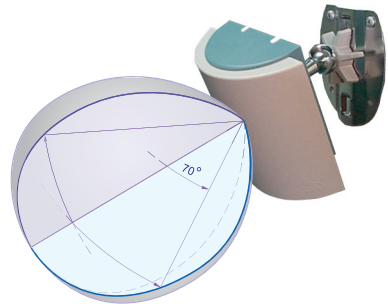

Overlook

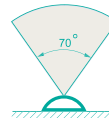

Horizontal coverage

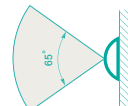

Vertical coverage

Remove one default antenna from the wireless device and start to assemble!

### Wall mount

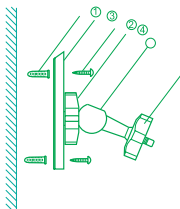

### Pole mount

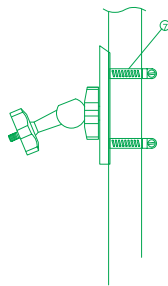

### Installation Note:

The following parts are needed for wall mounting:

1. plastic wall anchors (4) screws
2. wall screws
3. mounting base
4. locking wheel on the mounting base
5. adjustable pivot arm
6. locking wheel for pivot arm

### Package Contents:

- ANT24-0801 Antenna
- Extension Cable ( 3m )
- Mounting Kit
- Surge Protector
- Water-proof tape
- Quick Installation Guide

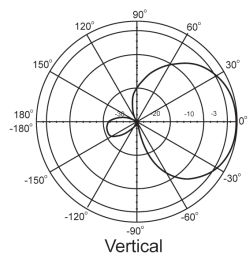

Vertical

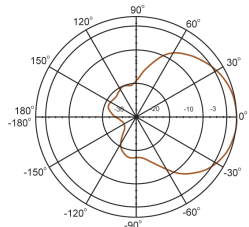

Horizontal

# D-Link ANT24-1200 Indoor Directional Panel Antenna

## Electrical specification

Frequency range	2400 MHz - 2500 MHz
Gain	12 dBi
VSWR	1.5 : 1 Max
Polarization	Linear, vertical
HPBW / horizontal	80°
HPBW / vertical	23°
Front to back ratio	15 dB
Downtilt	0°
Power handling	20 W(cm)
Impedance	50 Ohms
Connector	SMA female

## Environmental & Mechanical Characteristics

Survival wind speed	180 km/hr
Temperature	-10°C to +55°C
Humidity	95% @ 55°C
Lightning protection	DC ground
Radome color	White
Radome material	ABS, UV resistant
Weight	19 kgw
Dimensions	330 x 93 x 20.7 mm

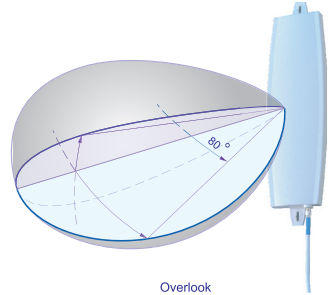

Overlook

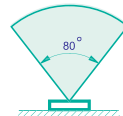

Horizontal coverage

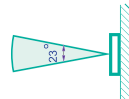

Vertical coverage

Remove one default antenna from the wireless device and start to assemble!

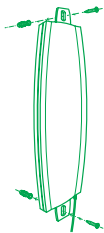
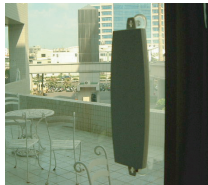

Wall mount with plastic wall plug



Window suction mount with widow suction cup

## Package Contents:

- ANT24-1200 Antenna
- Extension Cable ( 3m )
- Mounting Kit
- Quick Installation Guide

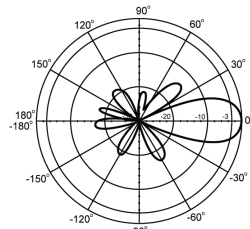

Vertical

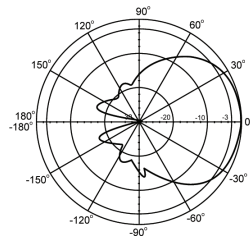

Horizontal



# D-Link ANT24-1201 Outdoor Directional Yagi Antenna

## Electrical specification

Frequency range	2400 MHz - 2500 MHz
Gain	12 dBi
VSWR	1.5 : 1 Max
Polarization	Linear, vertical
HPBW / horizontal	50°
HPBW / vertical	50°
Front to back ratio	15 dB
Downtilt	0°
Power handling	10 W (cm)
Impedance	50 Ohms
Connector	N female
Cable	UL 198; 32cm

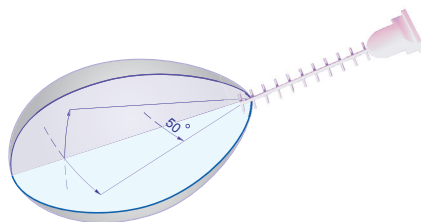

Overlook

## Environmental & Mechanical Characteristics

Survival wind speed	216 km/hr
Temperature	-40° C to +80° C
Humidity	95% @ 25 C°
Lightning protection	DC ground
Radome color	Gray-White
Radome material	ABS, UV resistant fire retardant
Weight	0.3 kgw
Dimensions	280 x 87x 48 mm

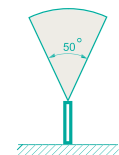

Horizontal coverage

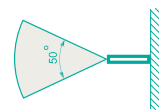

Vertical coverage

Remove one default antenna from the wireless device and start to assemble!

### Wall Mount

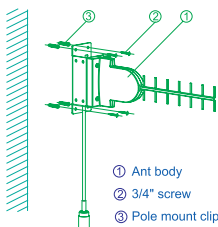

- ① Ant body
- ② 3/4" screw
- ③ Pole mount clip

### Pole Mount

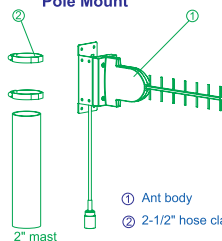

- ① Ant body
- ② 2-1/2" hose clamp

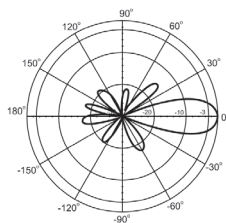

Vertical

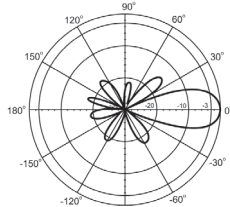

Horizontal

## Package Contents:

- ANT24-1201 antenna
- Extension cable ( 50cm )
- Mounting kit
- Surge protector
- Water-proof tape
- Quick installation guide

# D-Link ANT24-1400 Outdoor Directional Panel Antenna

## Electrical specification

Frequency range	2400 MHz - 2500 MHz
Gain	14 dBi
VSWR	1.5 : 1 Max
Polarization	Linear, vertical
HPBW / horizontal	30°
HPBW / vertical	30°
Front to back ratio	15 dB
Down tilt	0°
Power handling	10 W (cm)
Impedance	50 Ohms
Connector	N female
Cable	ULA198

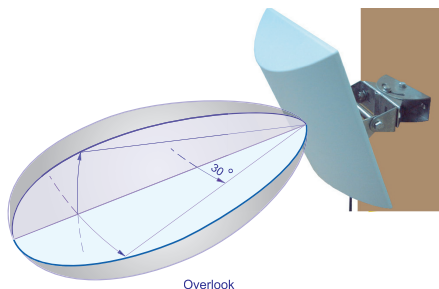

Overlook

## Environmental & Mechanical Characteristics

Survival wind speed	216 km/hr
Temperature	-40°C to +80°C
Humidity	100% @ 25°C
Lightning protection	DC ground
Radome color	Gray-White
Radome material	ABS, UV resistant
Weight	0.825 kgw
Dimensions	240 x 240x 69.5 mm

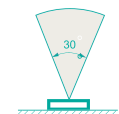

Horizontal coverage

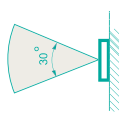

Vertical coverage

Remove one default antenna from the wireless device and start to assemble!

## Wall mount

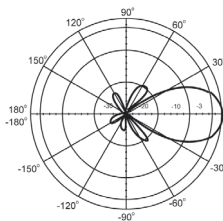
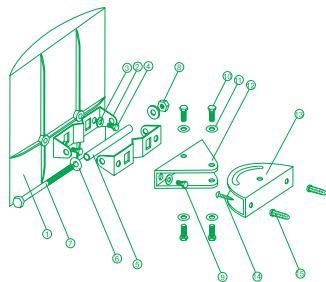

Vertical

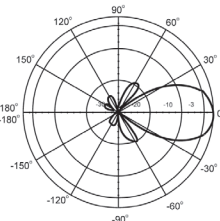

Horizontal

## Installation Note:

Required parts for wall mounting:

1. ANT-1400 antenna body with 2 screw holes
2. M-shaped metal fixing
3. spring washers 8mm
4. bolts M8 x 12
5. steel tubes
6. 8mm washer
7. bolt M8 x 110
8. nut M8 with lock washer
9. bolts M8 x16 with lock washer, washers and nuts
10. bolts M6 x10 with washers
11. 6mm washers
12. triangular stand
13. half-round metal stand
14. wall screws
15. plastic wall anchor

## Package Contents:

- ANT24-1400 Antenna
- Extension Cable ( 50cm )
- Mounting Kit
- Surge protector
- Water-proof tape
- Quick Installation Guide

# D-Link ANT24-1400(cont.) Outdoor Directional Panel Antenna

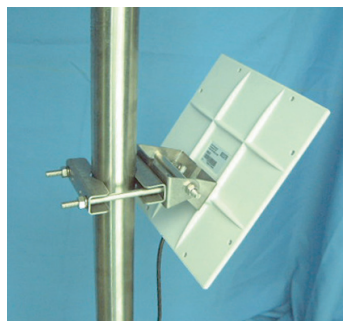
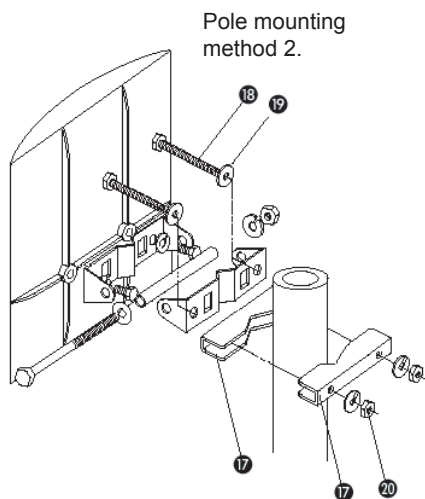
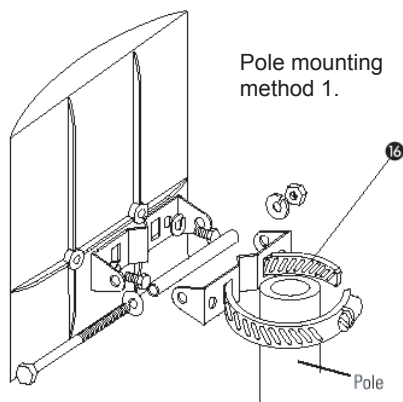

# D-Link ANT24-1500 Outdoor Omni-Directional Panel Antenna

## Electrical specification

Frequency Range	2400~2500 MHz
Impedance	50 OHMS $\pm 5\Omega$
SWR	1=1.3 Max
Gain	15 dBi
Radiation	Omni directional
Polarization	Vertical

## Mechanical Properties

Connector	N ( FEMALE)
Weight	1050 g
Radiator	Copper
Radome	Fiberglass
Mounting	Zinc
Guide Pipe	Aluminum Alloy
Bracket	Aluminum Alloy

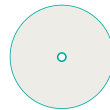

Horizontal coverage

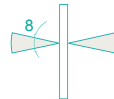

Vertical coverage

## Magnetic Attach

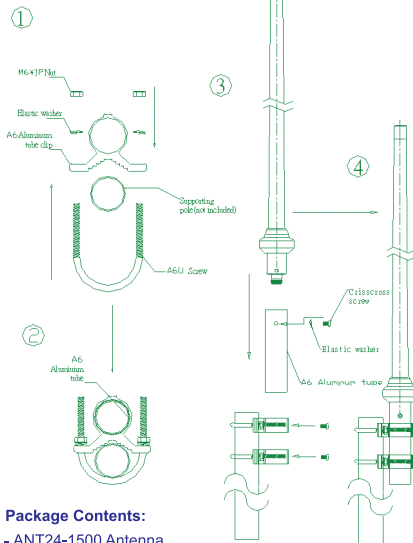

## Package Contents:

- ANT24-1500 Antenna
- DHF extension cable(3m, N male-RPSMA)
- Mounting kit
- Waterproof tape
- Quick Installation Guide

## E-PLANE FIELD PATTERNS

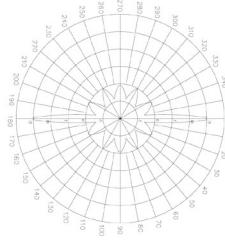

## H-PLANE FIELD PATTERNS

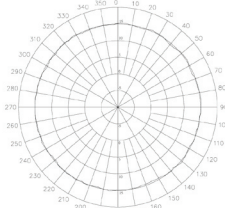

# D-Link ANT24-1800 Outdoor Directional Panel Antenna

## Electrical specification

Frequency range	2400 MHz - 2500 MHz
Gain	18 dBi
VSWR	1.5 : 1 Max
Polarization	Linear, vertical
HPBW / horizontal	15°
HPBW / vertical	15°
Front to back ratio	26 dB
Downtilt	0°
Power handling	50 W (cm)
Impedance	50 Ohms
Connector	N female

## Environmental & Mechanical Characteristics

Survival wind speed	216 km/hr
Temperature	-40° C to +80° C
Humidity	100% @ 25° C
Lightning protection	DC ground
Radome color	White
Radome material	ABS, UV resistant
Housing material	Galvanized Iron, Fire retardant
Weight	1.6 kgw
Dimensions	360 x 360x 16 mm <sup>3</sup>

Remove one default antenna from the wireless device and start to assemble!

### Wall mounting

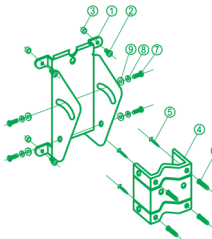

- ① Mounting base - 1 PC
- ② M4\*B screw+W/S/W - 4 PCS
- ③ Space keeper - 4 pcs
- ④ M-shape mounting - 1 pc
- ⑤ 3/4" screw - 4 pcs
- ⑥ Plastic wallplug - 4 pcs
- ⑦ M6\*16 screw - 4 pcs
- ⑧ M6 S/W - 4 pcs
- ⑨ M6 W - 4 pcs

### Pole mounting

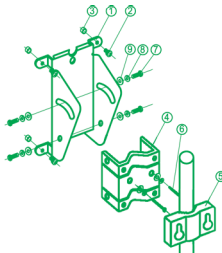

- ① Mounting base - 1 PC
- ② M4\*B screw+W/S/W - 4 PCS
- ③ Space keeper - 4 pcs
- ④ M-shape mounting - 1 pc
- ⑤ Pole mount clip - 1 pc
- ⑥ M6\*10 screw - 2 pcs
- ⑦ M6\*16 screw - 4 pcs
- ⑧ M6 S/W - 4 pcs
- ⑨ M6 W - 4 pcs

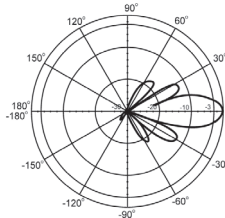
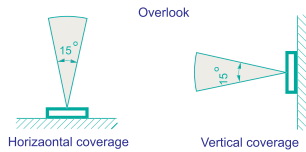
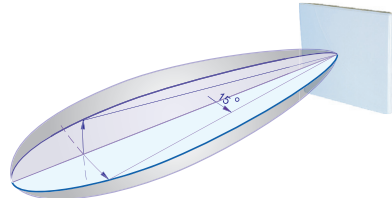

### Vertical

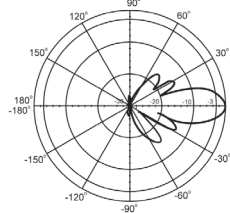

### Horizontal

## Package Contents:

- ANT24-1800 Antenna
- Extension Cable ( 50cm )
- Mounting Kit
- Surge protector
- Water-proof tape
- Quick Installation Guide

# D-Link ANT24-1801 Outdoor Directional Panel Antenna

## Electrical specification

Frequency range	2400 MHz - 2700 MHz
Gain	18 dBi
VSWR	1.5 : 1 Max
Polarization	Linear, vertical
HPBW / horizontal	15°
HPBW / vertical	15°
Front to back ratio	25 dB
Power handling	10 W (cm)
Impedance	50 Ohms
Connector	N female

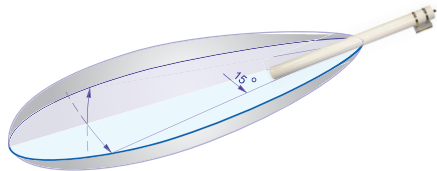

Overlook

## Environmental & Mechanical Characteristics

Survival wind speed	216 km/hr
Temperature	-40°C to +80°C
Humidity	95% @ 25°C
Lightning protection	DC ground
Radome color	White
Radome material	ABS, UV resistant
Weight	3.5 kgw
Dimensions	1000 x ø89 mm



Horizontal coverage

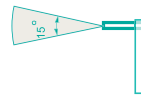

Vertical coverage

Remove one default antenna from the wireless device and start to assemble!

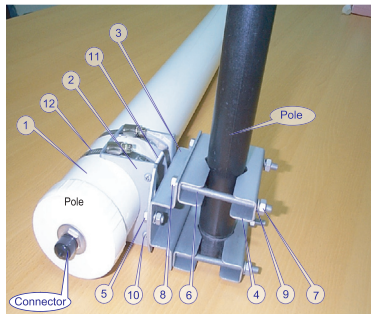

### Installation Note:

1. Main body
2. Angle mounting
3. Mounting bracket
4. 2" pole clamp
5. M8x 20 bolt
6. M8x 110 bolt
7. M8 nut
8. M8 washer
9. M8 spring washer
10. M6-95 screw
11. M6 nut
12. Band clamp

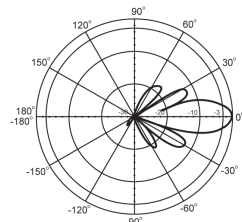

Vertical

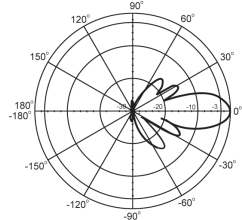

Horizontal

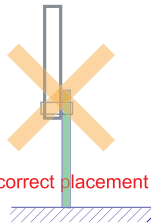

### Package Contents:

- ANT24-1801 Antenna
- Extension Cable ( 50cm )
- Mounting Kit
- Surge protector
- Water-proof tape
- Quick Installation Guide

# D-Link ANT24-2100

## Outdoor Directional Antenna

### Electrical specification

Frequency Range	2400~2500 MHz
Impedance	50 OHMS $\pm 5\Omega$
VSWR	1=1.5 Max
Gain	21 dBi
Radiation	Directional
Polarization	Vertical

### Physical Properties

Connector	N-FEMALE
Weight	4.21kg
Radiator	Steel
Radome	Fiberglass
Size	$\phi 610\text{mm} \times 150\text{mm}$
Bracket	Stainless Steel

### Magnetic Attach

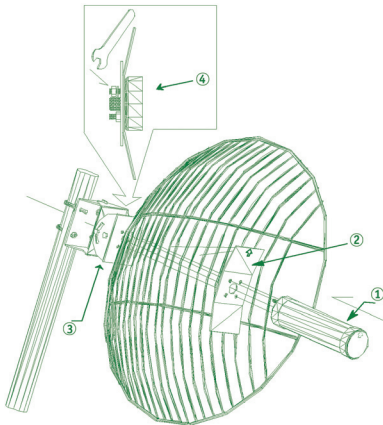

### Package Contents:

- ANT24-2100 Antenna
- DHF extension cable(3m, N male/RP-SMA)
- Mounting kit
- Waterproof tape
- Quick Installation Guide

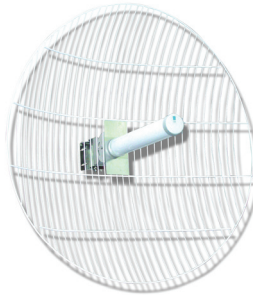

Horizontal coverage

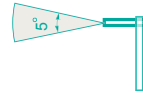

Vertical coverage

### E-PLANE FIELD PATTERNS

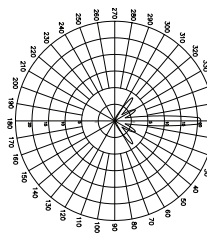

### H-PLANE FIELD PATTERNS

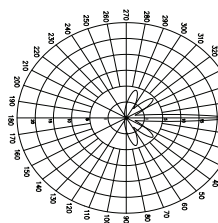

# D-Link ANT70-0800 Dual-Band Omni-Directional Antenna

## Electrical specification

Frequency Range	2400 MHz - 2500 MHz	4900 MHz - 5470 MHz
Gain	8 dBi	8 dBi
VSWR	2.0 : 1 Max.	
HPBW / horizontal	360°	
HPBW / vertical	15°	
Polarization	Linear, vertical	
Power handling	5 W (cw)	
Impedance	50 Ohms	
Connector	N Jack	

## Environmental & Mechanical Characteristics

Survival wind speed	216 km/hr
Temperature	- 40°C to +70°C
Humidity	95% @ 55°C
Radome color	Gray
Radome material	ABS, UV resistant
Weight	350 g
Dimensions	80x78x870 mm

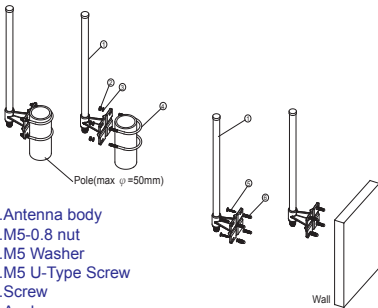
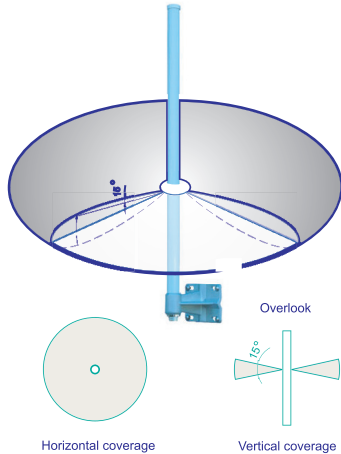

1. Antenna body
2. M5-0.8 nut
3. M5 Washer
4. M5 U-Type Screw
5. Screw
6. Anchor

## Package Contents

- D-Link ANT70-0800 Antenna
- Extension Cable(50cm)
- Surge Protector
- Mounting Kit
- Water-proof tape
- Quick Installation Guide

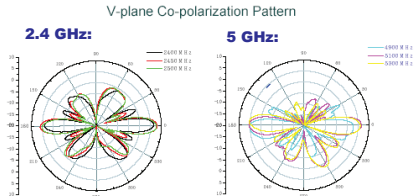
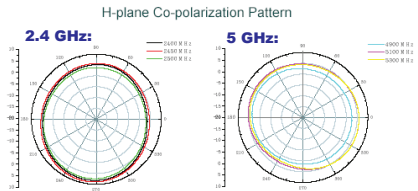



# D-Link ANT70-0801

## Dual-Band Omni-Directional Antenna

### Electrical specification

Frequency Range	2400 MHz - 2500 MHz	5400 MHz - 5875 MHz
Gain	8 dBi	8 dBi
VSWR	2.0 : 1 Max.	
HPBW / horizontal	360°	
HPBW / vertical	15°	
Polarization	Linear, vertical	
Power handling	5 W (cw)	
Impedance	50 Ohms	
Connector	N Jack	

### Environmental & Mechanical Characteristics

Survival wind speed	216 km/hr
Temperature	- 40°C to +70°C
Humidity	95% @ 55°C
Radome color	Gray
Radome material	ABS, UV resistant
Weight	350 g
Dimensions	80x78x870 mm

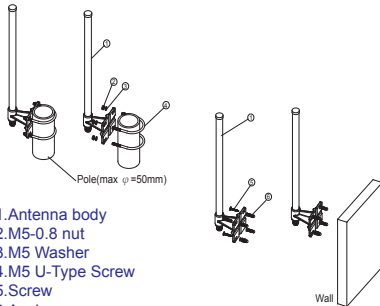
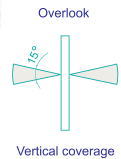
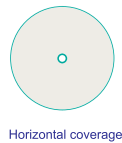
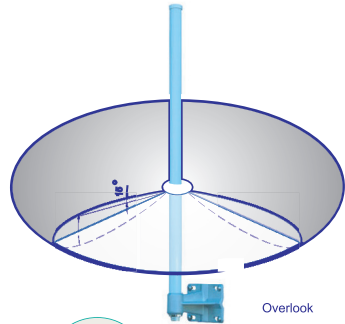

1. Antenna body
2. M5-0.8 nut
3. M5 Washer
4. M5 U-Type Screw
5. Screw
6. Anchor

### Package Contents

- D-Link ANT70-0801 Antenna
- Extension Cable(50cm)
- Surge Protector
- Mounting Kit
- Water-proof tape
- Quick Installation Guide

H-plane Co-polarization Pattern

2.4 GHz:

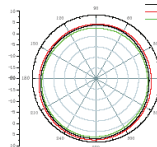

5 GHz:

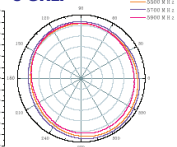

V-plane Co-polarization Pattern

2.4 GHz:

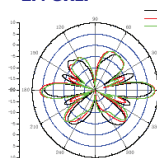

5 GHz:

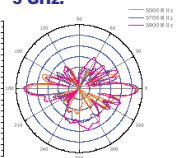

## D-Link ANT70-1000 Dual-Band Directional Panel Antenna

### Electrical specification

Frequency Range	2400 MHz - 2500 MHz	4900 MHz - 5875 MHz
Gain	8.5 dBi	10.5 dBi
VSWR	2.0 : 1 Max.	2.0 : 1 Max.
HPBW / horizontal	58°	45°
HPBW / vertical	55°	45°
Polarization	Linear, vertical	
Power handling	5 W (cw)	
Front to back ratio	15dB	
Downtilt	0°	
Impedance	50 Ohms	
Connector	N Jack	



### Environmental & Mechanical Characteristics

Survival wind speed	216 km/hr
Temperature	- 40°C to +80°C
Humidity	95% @ 55°C
Radome color	Gray
Radome material	ABS, UV resistant
Weight	150 g
Dimensions	114 x124 x 40 mm

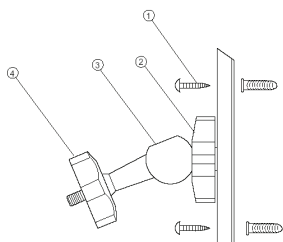

1. Insert the tapping screw ① to fix the whole set of universal joint on the wall
2. Rotate the mounting base of the antenna to connect antenna body and universal joint
3. Fix the mounting base by rotate the rotating handle ④
4. Adjust the ball joint ③ to the convenient angle. Rotate the handle to fix the ball joint ②

1. Taping Screw
2. Rotate Handle
3. Ball Joint
4. Rotating Handle

### Package Contents

- D-Link ANT70-1000 Antenna
- Extension Cable(50cm)
- Surge Protector
- Mounting Kit
- Water-proof tape
- Quick Installation Guide

### 2.4 GHz:



Horizontal coverage

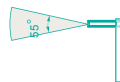

Vertical coverage

### 5 GHz:



Horizontal coverage

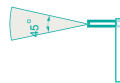

Vertical coverage

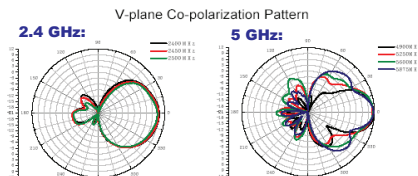
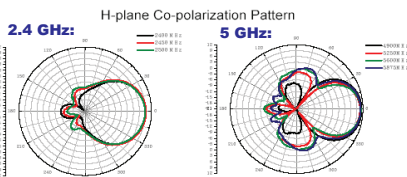

# D-Link ANT70-1800

## Dual-Band Directional Panel Antenna

### Electrical specification

Frequency Range	2400 MHz - 2500 MHz	4900 MHz - 5875 MHz
Gain	14 dBi	18 dBi
VSWR	2.0 : 1 Max.	2.0 : 1 Max.
HPBW / horizontal	30°	15°
HPBW / vertical	30°	15°
Polarization	Linear, vertical	
Power handling	10 W (cw)	
Front to back ratio	15dB	
Down tilt	0°	
Impedance	50 Ohms	
Connector	N Jack	

### Environmental & Mechanical Characteristics

Survival wind speed	216 km/hr
Temperature	-40°C to +80°C
Humidity	95% @ 55°C
Radome color	Light Gray
Radome material	ABS, UV resistant
Weight	400 g
Dimensions	200 x 218 x 50 mm

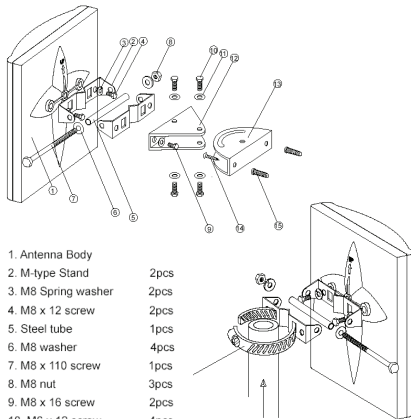

1. Antenna Body
2. M-type Stand 2pcs
3. M8 Spring washer 2pcs
4. M8 x 12 screw 2pcs
5. Steel tube 1pcs
6. M8 washer 4pcs
7. M8 x 110 screw 1pcs
8. M8 nut 3pcs
9. M8 x 16 screw 2pcs
10. M6 x 12 screw 4pcs
11. M6 washer 4pcs
12. Triangle stand
13. Main stand
14. Screw 2pcs
15. Plastic conical anchor 2pcs
16. Hose Clamp 2-1/2"

### Package Contents

- D-Link ANT70-1800 Antenna
- Extension Cable(50cm)
- Surge Protector
- Mounting Kit
- Water-proof tape
- Quick Installation Guide



### 2.4 GHz:



Horizontal coverage

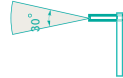

Vertical coverage

### 5 GHz:



Horizontal coverage

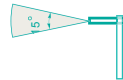

Vertical coverage

### H-plane Co-polarization Pattern

#### 2.4 GHz:

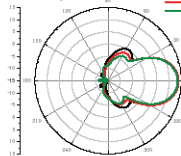

#### 5 GHz:

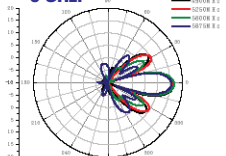

### V-plane Co-polarization Pattern

#### 2.4 GHz:

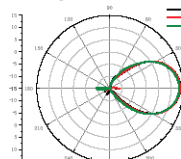

#### 5 GHz:

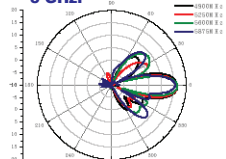

# Fresnel Zone

## Line-of-Sight (LOS)

Visual and RF Line-of-Sight ( LOS ) between the sending and receiving antennas is essential in achieving long range in wireless communication systems. There are two types of LOS that are generally used to describe an environment:

Visual LOS is the ability to see from one site to the other. It requires only a straight liner path between two points.

RF LOS requires not only visual LOS, but also a football-shaped path free of obstacles for data to optimally travel from one point to another.

Fresnel Zone:

The Fresnel Zone can be thought of as a football-shaped tunnel between two sites that provides a path for RF signals.

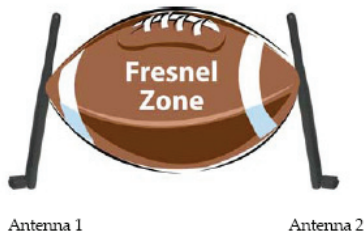

In order to achieve the greatest range, the football-shaped path in which radio waves travel must be free of obstructions. Buildings, trees or any other obstacles in the path will decrease the communication range. If the antennas are mounted just barely off the ground, over half of the Fresnel zone ends up being obstructed by the earth resulting in significant reduction in range. To avoid this problem, the antenna should be mounted high enough off of the ground so that the earth does not interfere with the central radius of the Fresnel zone.

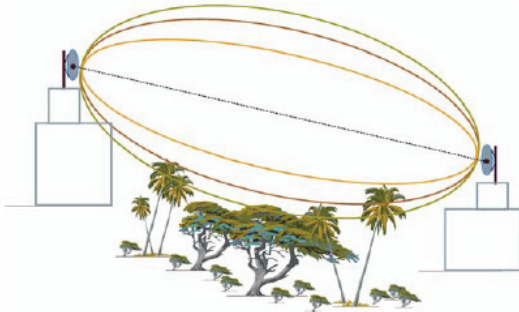

How far above the ground and other obstacles the antennas need to be is determined by the radius of the Fresnel zone. The radius of the Fresnel Zone depends upon the frequency and distance between the two antennas. The following table provides approximate Fresnel zone radius:

In order to have LOS clearance, the combined antenna height should be equal to or at least 70% of the radius of the Fresnel zone.

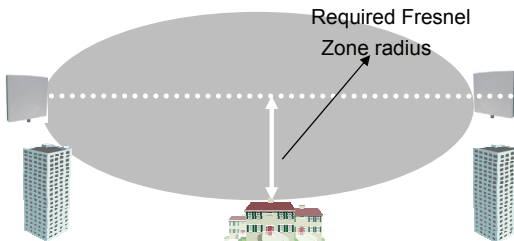

Fresnel Zone Radius:

Range Distance between antennas	Required Fresnel Zone Radius ( 2.4GHz Radius)	Required Fresnel Zone Radius ( 5GHz Radius)
300m	3.06m	2.12m
1.6Km	7.07m	4.9m
8Km	15.81m	10.95m
10Km	17.68m	12.25m
15Km	21.65m	15m

						
Model Name	ANT24-0401	ANT24-0500	ANT24-0501	ANT24-0501C	ANT24-0600	DWL-R60AT
Frequency	2.4GHz	2.4GHz	2.4GHz	2.4GHz	2.4GHz	2.4GHz
Signal directivity	Omni-directional	Omni-directional	Omni-directional	Omni-directional	Directional Antenna	Directional Antenna
Application range	Indoor ceiling only	Indoor/ Outdoor	Indoor only	Indoor only	Indoor only	Indoor only
Gain (Without cable loss)	3.5dBi	5dBi	5dBi	5dBi	6dBi	6dBi
Approximate Range at 1/11/54Mbps (Works with Indoor AP)	250m/100m / 40 m	500m/250m/60m	500m/200m/50m	550m/250m/60m	600m/350m/80m	600m/350m / 80m
Approximate Range at 1/11/54Mbps (Works with Outdoor AP)	---	1.5Km/ 1.3Km/ 200m	---	---	---	---
Half Power Beam width	H360 V120	H360 V32	H360 V36	H360 V36	H68 V80	H70 V85
Pigtail cable length	---	30cm	150cm	---	150cm	---
Antenna fixed connector	RP-SMA jack	N-jack	RP-SMA plug	RP-SMA plug	RP-SMA plug	RP-SMA plug
Surge protector for outdoors	---	Optional	---	---	---	---
Default extension cable length	2M	3M	---	---	---	---
Default mounting configuration	Ceiling	Pole	Wall / desktop/magnetic	Attach to AP/Router	Wall/ desktop/magnetic	Attach to AP/Router
Optional accessories	---	ANT24-SP	---	---	---	---
Optional antenna cable kits	---	ANT24-CB series ANT24-ODU series ANT24-DLK series	---	---	---	---

						
Model Name	ANT24-1201	ANT24-1200	ANT24-0801	ANT24-0800	ANT24-0700C	ANT24-0700
Frequency	2.4GHz	2.4GHz	2.4GHz	2.4GHz	2.4GHz	2.4GHz
Signal directivity	Directional	Directional	Directional	Omni-directional	Omni-directional	Omni-directional
Application range	Indoor only	Indoor only	Indoor/ Outdoor	Indoor/ Outdoor	Indoor only	Indoor only
Gain (Without cable loss)	12dBi	12dBi	8.5dBi	8dBi	7dBi	7dBi
Approximate Range at 1/11/54Mbps (Works with Indoor AP)	---	1.5Km / 1.2Km/ 500m	800m/ 500m/ 150m	700m/ 350m/ 100m	600m/ 300m/ 70m	550m/ 250m/ 80m
Approximate Range at 1/11/54Mbps (Works with Outdoor AP)	3Km / 2.5Km/ 1Km	---	2.5Km/ 1.5Km/ 600m	2Km / 1Km/ 400m	---	---
Half Power Beam width	H50 V50	H80 V23	H70 V65	H960 V15	H360 V24	H360 V24
Pigtail cable length	30cm	NA	30cm	NA	150cm	150cm
Antenna fixed connector	N-jack	SMA jack	N-jack	N-jack	RP-SMA plug	RP-SMA plug
Surge protector for outdoors	Included	---	Included	Included	---	---
Default extension cable length	50cm	3M	3M	50cm	---	---
Default mounting configuration	Wall/ pole	Window/ wall	Wall/ pole	Pole	Attach to AP/Router	Wall/ desktop/magnetic
Optional accessories	---	---	---	---	---	---
Optional antenna cable kits	ANT24-CB series ANT24-DLX series ANT24-DLX series	---	ANT24-CB series ANT24-DLX series ANT24-DLX series	ANT24-CB series ANT24-DLX series ANT24-DLX series	---	---

				
Model Name	ANT24-1400	ANT24-1500	ANT24-1800	ANT24-1801
Frequency	2.4GHz	2.4GHz	4.6GHz	2.4GHz
Signal directivity	Directional	Omni-directional	Directional	Directional
Application range	Outdoor	Outdoor	Outdoor	Outdoor
Gain (Without cable loss)	14dBi	15dBi	18dBi	21dBi
Approximate Range at 1/11/54Mbps (Works with Indoor AP)	---	---	---	---
Approximate Range at 1/11/54Mbps (Works with Outdoor AP)	6Km / 4.5Km/ 1Km	4Km / 2.5Km/ 500m	8Km / 6Km/ 1.5Km	12Km / 9Km/ 2.5Km
Half Power Beam width	H30 V30	H360 V8	H15 V15	H5 V8
Pigtail cable length	30cm	---	---	---
Antenna fixed connector	N-jack	N-jack	N-jack	N-jack
Surge protector for outdoors	Included	Included	Included	Included
Default extension cable length	50cm	3M	50cm	3M
Default mounting configuration	Wall/ pole	Pole	Wall/ pole	Pole
Optional accessories	---	---	---	---
Optional antenna cable kits	ANT24_CS series ANT24_ODL series ANT24-DLK series	ANT24_CS series ANT24_ODL series ANT24-DLK series	ANT24_CS series ANT24_ODL series ANT24-DLK series	ANT24_CS series ANT24_ODL series ANT24-DLK series



			
Model Name	ANT70-0800	ANT70-0801	ANT70-1000
Frequency	2.4GHz/ 5GHz	2.4GHz/ 5GHz	2.4GHz/ 5GHz
Signal directivity	Omnidirectional	Omnidirectional	Directional
Application range	Indoor/ Outdoor	Indoor/ Outdoor	Indoor/ Outdoor
Gain (Without cable loss)	2.4GHz: 8dBi 5GHz: 8dBi	2.4GHz: 8dBi 5GHz: 8dBi	2.4GHz: 14dBi 5GHz: 18dBi
Approximate Range at 1/11/54Mbps (Works with Indoor AP)	2.4GHz: 700m/ 350m/ 100m 5GHz: 1K/ 500m/ 200m	2.4GHz: 700m/ 350m/ 100m 5GHz: 1K/ 500m/ 200m	2.4GHz: 800m/ 400m/ 150m 5GHz: 1.2K/ 600m/ 250m
Approximate Range at 1/ 11 /54Mbps (Works with Outdoor AP)	2.4GHz: 800m/ 450m/ 150m 5GHz: 1K/ 500m/ 200m	2.4GHz: 800m/ 450m/ 150m 5GHz: 1K/ 500m/ 200m	2.4GHz: 6K/ 4.5m/ 1Km 5GHz: 8Km/ 5Km/ 1.5Km
Half Power Beam width	2.4GHz: H360 V15 5GHz: H360 V15	2.4GHz: H360 V15 5GHz: H360 V15	2.4GHz: H30 V30 5GHz: H15 V15
Pigtail cable length	NA	NA	NA
Antenna fixed connector	N-jack	N-jack	N-jack
Surge protector for outdoors	Included	Included	Included
Default extension cable length	50cm	50cm	50cm
Default mounting configuration	Pole	Pole	Pole
Optional accessories	---	---	---
Optional antenna cable kits	ANT24-CB series ANT24-ODU series ANT24-DLK series	ANT24-CB series ANT24-ODU series ANT24-DLK series	ANT24-CB series ANT24-ODU series ANT24-DLK series

**NOTE:**

- \*1. Extended range reference based on RF-Output Power 16dbm( Indoor AP), 23 ( outdoor AP) with default cable loss.
  - \*2. The transmission distance range might depend on the two same spec antennas with default cable loss under free line-of -sight environment.
  - \*3. Effective range based on EIRP/Effective Isotropic Radiation Power. = device output power + antenna gain – cable loss )
- \*\*BW: Beam Width, H : horizontal plane pattern, V : vertical plane pattern  
The actual range will be effected by users' physical environment. The above figures are reference.

# (Appendix)

## CONNECTORS OUTLOOK

